

Power is our commodity, the world is our market !

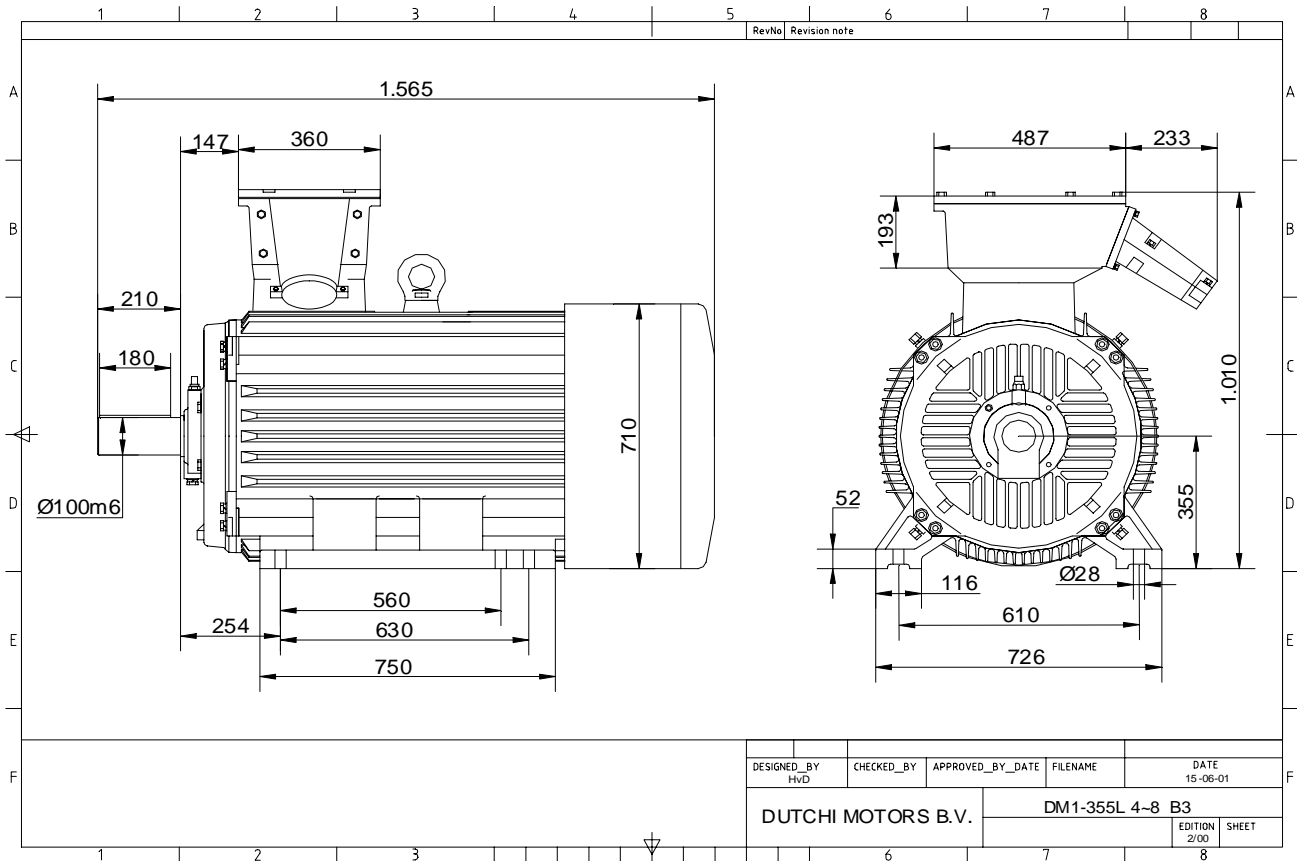

Specification	<b>IEC 60034-1</b>
Manufacturer	<b>Dutchi Motors B.V.</b>
Motor type	<b>DM1- 355 L8</b>
Rated power	<b>180</b> kW <b>S1</b> duty
Speed	<b>745</b> r.p.m
Voltage	<b>400</b> / <b>690</b> V
Frequency	<b>50</b> Hz
Connection	<b>Δ</b> / <b>Y</b>
Amps full load	<b>327</b> / <b>189</b> A
Amps no-load(400V)	<b>121</b> A
Enclosure	<b>IP 55</b>
Insulation Class	<b>F (temp. rise B (80 K))</b>
Max. coolant temp.	<b>40°C</b>
Max. altitude	<b>1.000</b> mtr, above sea level
Comment	<b>3 x PTC 150°C</b>
Cable entries	<b>2 x Ø 70 mm + 1 x M20x1,5 (ptc)</b>
Feature	<b>Cast-iron motor</b>
Weight	<b>1970</b> kg
Catalog no.	<b>11138B80D</b>
Warranty	<b>12~18 months</b>

Efficiency class	<b>N/A</b>			
Load data	100%	75%	50%	25%
Efficiency	<b>94,7</b>	<b>94,4</b>	<b>93,0</b>	<b>88,1</b> %
Power factor	<b>0,84</b>	<b>0,81</b>	<b>0,74</b>	<b>0,56</b>
Sound pressure level (1m)				<b>71,0</b> dB(A)
Resistance R20 (open)				<b>0,01452</b> Ω
Resistance R20	<b>Δ</b>			<b>0,00968</b> Ω
Full load torque				<b>2307</b> Nm
DOL Starting torque vs FL torque				<b>1,43</b>
DOL Pull up torque vs FL torque				<b>1,11</b>
DOL Pull out torque vs FL torque				<b>2,57</b>
Star-Delta Starting torque vs FL torque				<b>0,45</b>
Star-Delta Pull up torque vs FL torque				<b>0,35</b>
Star-Delta Pull out torque vs FL torque				<b>0,80</b>
DOL Starting current vs FL current				<b>5,14</b>
Star Delta Starting current vs FL current				<b>1,61</b>
Rotor Inertia				<b>15,82</b> kgm <sup>2</sup>
Bearing DE				<b>6322 - C3 or NU322</b>
Bearing NDE				<b>6322 - C3 (IM V1 7322B)</b>

WI	Change	date	sign.
<b>Dutchi Motors B.V.</b> P.O. Box 5390 NL-6802 EJ ARNHEM Tel : +31-(0)26 - 3541 600 Fax : +31-(0)26 - 3541 650		Discription Drawing made by :	date 27-04-04 sign. HvD
dutchi.motors@dutchi.nl www.dutchi.com			

Power is our commodity, the world is our market !

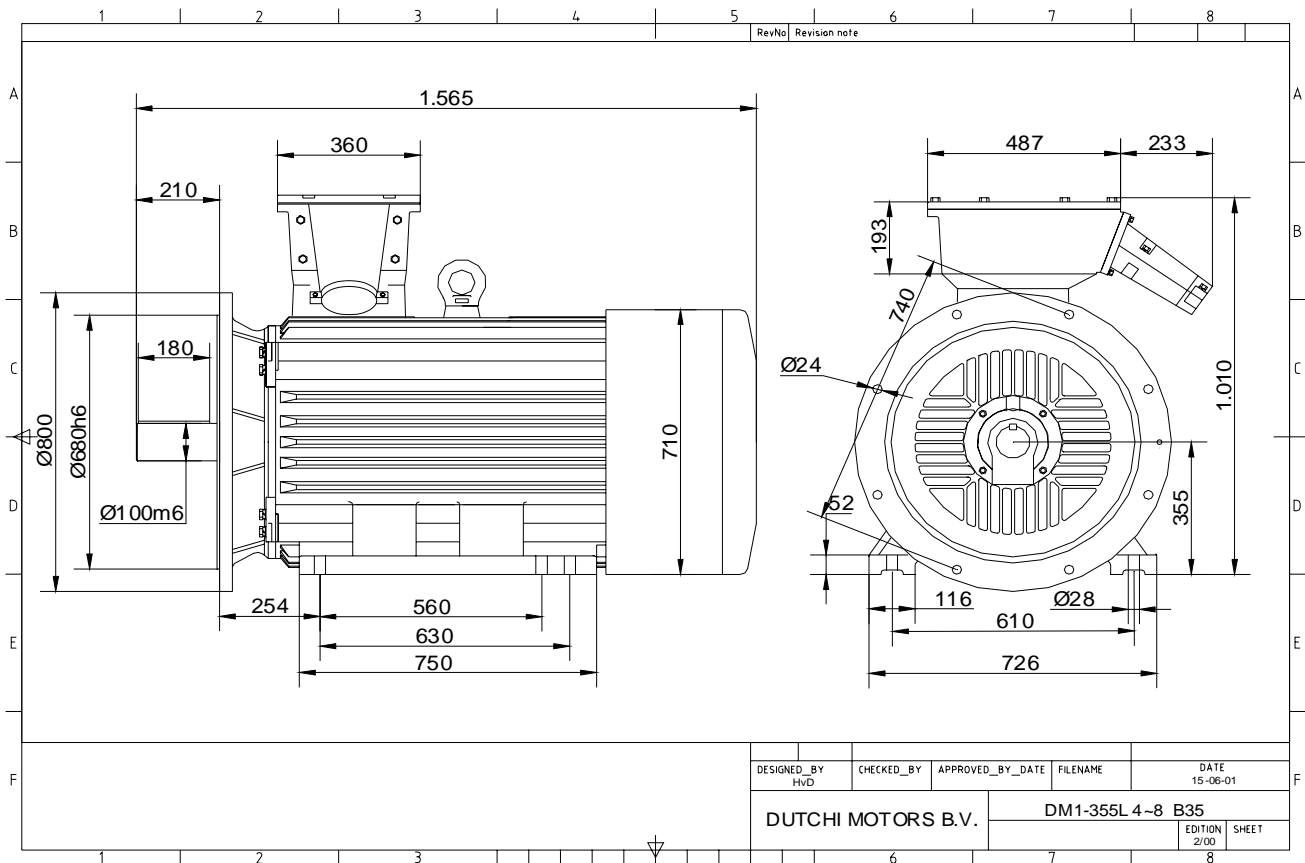

Specification **IEC 60034-1**  
 Manufacturer **Dutchi Motors B.V.**  
 Motor type **DM1- 355 L8**  
 Rated power **180** kW **S1** duty  
 Speed **745** r.p.m  
 Voltage **400** / **690** V  
 Frequency **50** Hz  
 Connection **Δ** / **Y**  
 Amps full load **327** / **189** A  
 Amps no-load(400V) **121** A  
 Enclosure **IP 55**  
 Insulation Class **F (temp. rise B (80 K))**

Max. coolant temp. **40°C**  
 Max. altitude **1.000** mtr, above sea level  
 Comment **3 x PTC 150°C**  
 Cable entries **2 x Ø 70 mm + 1 x M20x1,5 (ptc)**

Feature **Cast-iron motor**  
 Weight **1970** kg  
 Catalog no. **11538B80D**  
 Warranty **12~18 months**

Efficiency class **N/A**  
 Load data 100% 75% 50% 25%  
 Efficiency **94,7 94,4 93,0 88,1** %  
 Power factor **0,84 0,81 0,74 0,56**

Sound pressure level (1m) **71,0** dB(A)  
 Resistance R20 (open) **0,01452** Ω  
 Resistance R20 **Δ 0,00968** Ω

Full load torque **2307** Nm  
 DOL Starting torque vs FL torque **1,43**  
 DOL Pull up torque vs FL torque **1,11**  
 DOL Pull out torque vs FL torque **2,57**  
 Star-Delta Starting torque vs FL torque **0,45**  
 Star-Delta Pull up torque vs FL torque **0,35**  
 Star-Delta Pull out torque vs FL torque **0,80**  
 DOL Starting current vs FL current **5,14**  
 Star Delta Starting current vs FL current **1,61**  
 Rotor Inertia **15,82** kgm<sup>2</sup>

Bearing DE **6322 - C3 or NU322**  
 Bearing NDE **6322 - C3 (IM V1 7322B)**

WI	Change	date	sign.
<b>Dutchi Motors B.V.</b> P.O. Box 5390 NL-6802 EJ ARNHEM Tel : +31-(0)26 - 3541 600 Fax : +31-(0)26 - 3541 650		Description	date
		Drawing made by :	27-04-04
		<b>dutchi.motors@dutchi.nl</b> <b>www.dutchi.com</b>	

Power is our commodity, the world is our market !

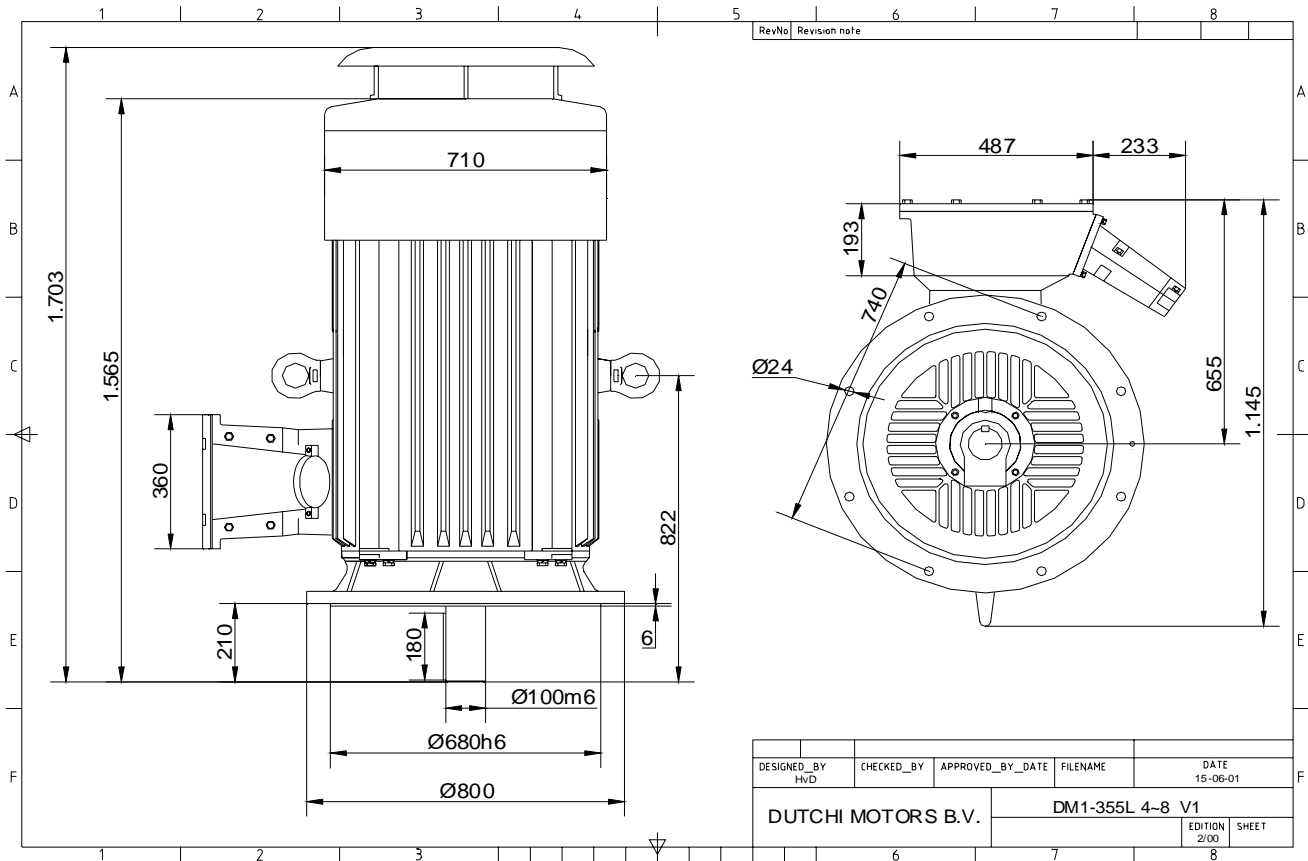

Specification **IEC 60034-1**  
 Manufacturer **Dutchi Motors B.V.**  
 Motor type **DM1- 355 L8**  
 Rated power **180** kW **S1** duty  
 Speed **745** r.p.m  
 Voltage **400** / **690** V  
 Frequency **50** Hz  
 Connection **Δ** / **Y**  
 Amps full load **327** / **189** A  
 Amps no-load(400V) **121** A  
 Enclosure **IP 55**  
 Insulation Class **F (temp. rise B (80 K))**

Max. coolant temp. **40°C**  
 Max. altitude **1.000** mtr, above sea level  
 Comment **3 x PTC 150°C**  
 Cable entries **2 x Ø 70 mm + 1 x M20x1,5 (ptc)**

Feature **Cast-iron motor**  
 Weight **1970** kg  
 Catalog no. **11038B80D**  
 Warranty **12~18 months**

Efficiency class **N/A**  
 Load data 100% 75% 50% 25%  
 Efficiency **94,7 94,4 93,0 88,1** %  
 Power factor **0,84 0,81 0,74 0,56**

Sound pressure level (1m) **71,0** dB(A)  
 Resistance R20 (open) **0,01452** Ω  
 Resistance R20 **Δ 0,00968** Ω

Full load torque **2307** Nm  
 DOL Starting torque vs FL torque **1,43**  
 DOL Pull up torque vs FL torque **1,11**  
 DOL Pull out torque vs FL torque **2,57**  
 Star-Delta Starting torque vs FL torque **0,45**  
 Star-Delta Pull up torque vs FL torque **0,35**  
 Star-Delta Pull out torque vs FL torque **0,80**  
 DOL Starting current vs FL current **5,14**  
 Star Delta Starting current vs FL current **1,61**  
 Rotor Inertia **15,82** kgm<sup>2</sup>

Bearing DE **6322 - C3 or NU322**  
 Bearing NDE **6322 - C3 (IM V1 7322B)**

WI	Change	date	sign.
Dutchi Motors B.V.		Description	date
P.O. Box 5390		Drawing made by :	27-04-04
NL-6802 EJ ARNHEM			
Tel : +31-(0)26 - 3541 600		dutchi.motors@dutchi.nl	
Fax : +31-(0)26 - 3541 650		www.dutchi.com	