

Power is our commodity, the world is our market !

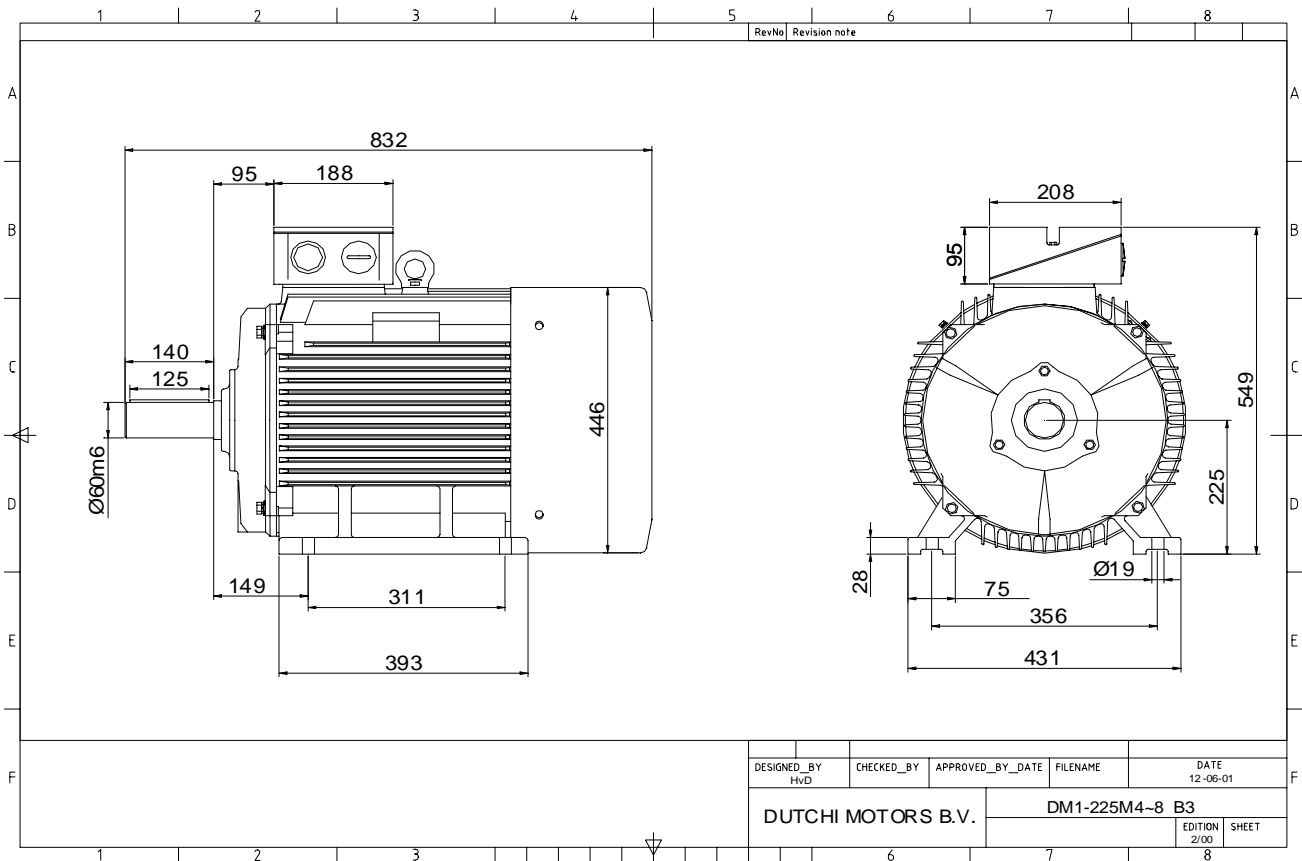

Specification	IEC 60034-1
Manufacturer	Dutchi Motors B.V.
Motor type	DM1- 225 M8
Rated power	22 kW S1 duty
Speed	730 r.p.m
Voltage	400 / 690 V
Frequency	50 Hz
Connection	Δ / Y
Amps full load	43,6 / 25,2 A
Amps no-load(400V)	21,90 A
Enclosure	IP 55
Insulation Class	F (temp. rise B (80 K))
Max. coolant temp.	40°C
Max. altitude	1.000 mtr, above sea level
Comment	3 x PTC 150°C
Cable entries	2 x M50x1,5 + 1 x M20x1,5 (ptc)
Feature	Cast-iron motor
Weight	294 kg
Catalog no.	11138A22D
Warranty	12~18 months

Efficiency class	N/A			
Load data	100%	75%	50%	25%
Efficiency	91,2	91,5	90,4	85,1 %
Power factor	0,80	0,75	0,64	0,41
Sound pressure level (1m)				61,3 dB(A)
Resistance R20 (open)				0,351 Ω
Resistance R20	Δ			0,234 Ω
Full load torque				287,81 Nm
DOL Starting torque vs FL torque				2,15
DOL Pull up torque vs FL torque				1,55
DOL Pull out torque vs FL torque				2,97
Star-Delta Starting torque vs FL torque				0,67
Star-Delta Pull up torque vs FL torque				0,48
Star-Delta Pull out torque vs FL torque				0,93
DOL Starting current vs FL current				7,09
Star Delta Starting current vs FL current				2,21
Rotor Inertia				0,5310 kgm ²
Bearing DE				6313 - ZZ C3
Bearing NDE				6313 - ZZ C3

WI	Change	date	sign.
Dutchi Motors B.V. P.O. Box 5390 NL-6802 EJ ARNHEM Tel : +31-(0)26 - 3541 600 Fax : +31-(0)26 - 3541 650		Discription Drawing made by :	date 27-04-04
dutchi.motors@dutchi.nl www.dutchi.com		sign. HvD	

Power is our commodity, the world is our market !

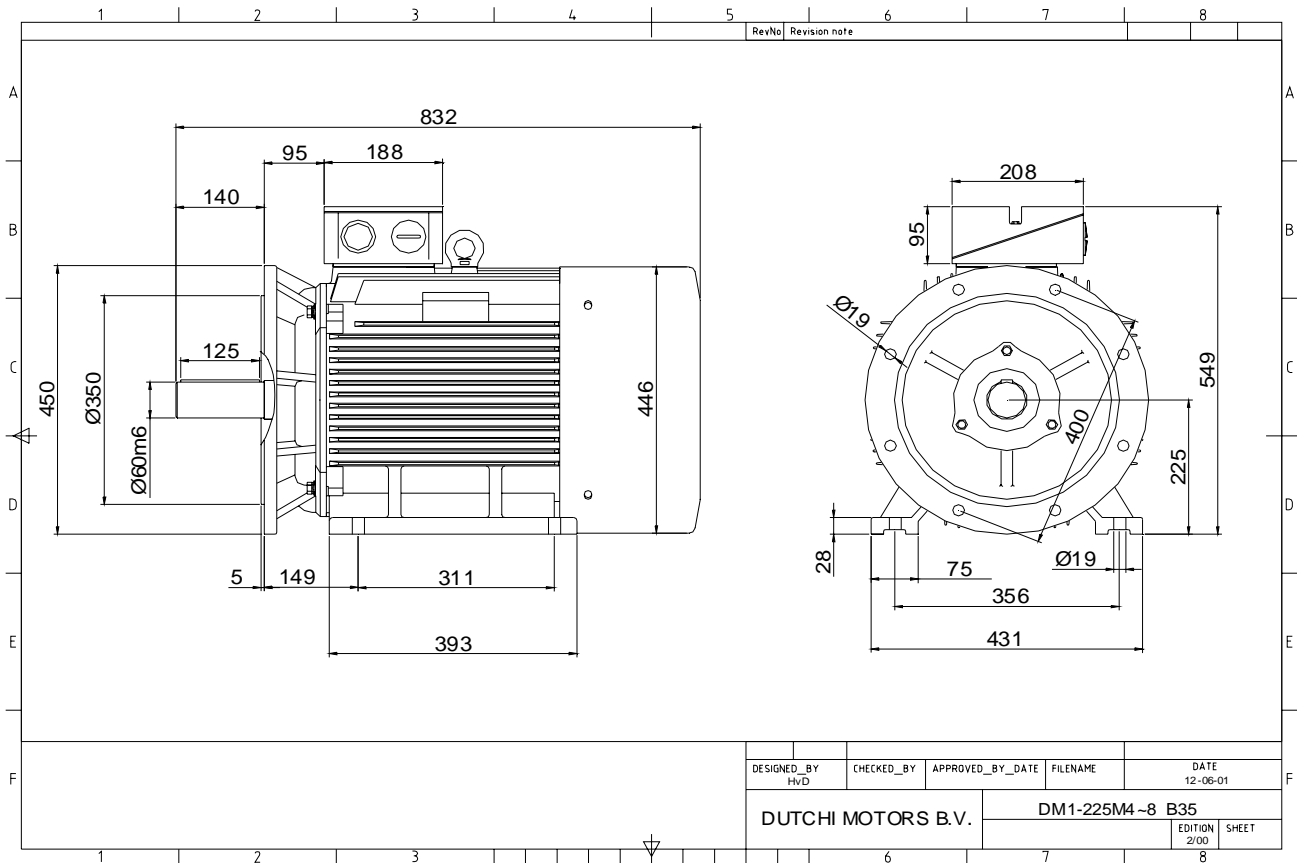

Specification	IEC 60034-1
Manufacturer	Dutchi Motors B.V.
Motor type	DM1- 225 M8
Rated power	22 kW S1 duty
Speed	730 r.p.m
Voltage	400 / 690 V
Frequency	50 Hz
Connection	Δ / Y
Amps full load	43,6 / 25,2 A
Amps no-load(400V)	21,90 A
Enclosure	IP 55
Insulation Class	F (temp. rise B (80 K))
Max. coolant temp.	40°C
Max. altitude	1.000 mtr, above sea level
Comment	3 x PTC 150°C
Cable entries	2 x M50x1,5 + 1 x M20x1,5 (ptc)
Feature	Cast-iron motor
Weight	294 kg
Catalog no.	11238A22D
Warranty	12~18 months

Efficiency class	N/A			
Load data	100%	75%	50%	25%
Efficiency	91,2	91,5	90,4	85,1 %
Power factor	0,80	0,75	0,64	0,41
Sound pressure level (1m)				61,3 dB(A)
Resistance R20 (open)				0,351 Ω
Resistance R20	Δ			0,234 Ω
Full load torque				287,81 Nm
DOL Starting torque vs FL torque				2,15
DOL Pull up torque vs FL torque				1,55
DOL Pull out torque vs FL torque				2,97
Star-Delta Starting torque vs FL torque				0,67
Star-Delta Pull up torque vs FL torque				0,48
Star-Delta Pull out torque vs FL torque				0,93
DOL Starting current vs FL current				7,09
Star Delta Starting current vs FL current				2,21
Rotor Inertia				0,5310 kgm ²
Bearing DE				6313 - ZZ C3
Bearing NDE				6313 - ZZ C3

WI	Change	date	sign.
Dutchi Motors B.V. P.O. Box 5390 NL-6802 EJ ARNHEM Tel : +31-(0)26 - 3541 600 Fax : +31-(0)26 - 3541 650		Discription Drawing made by :	date 27-04-04 sign. HvD
dutchi.motors@dutchi.nl www.dutchi.com			

Power is our commodity, the world is our market !

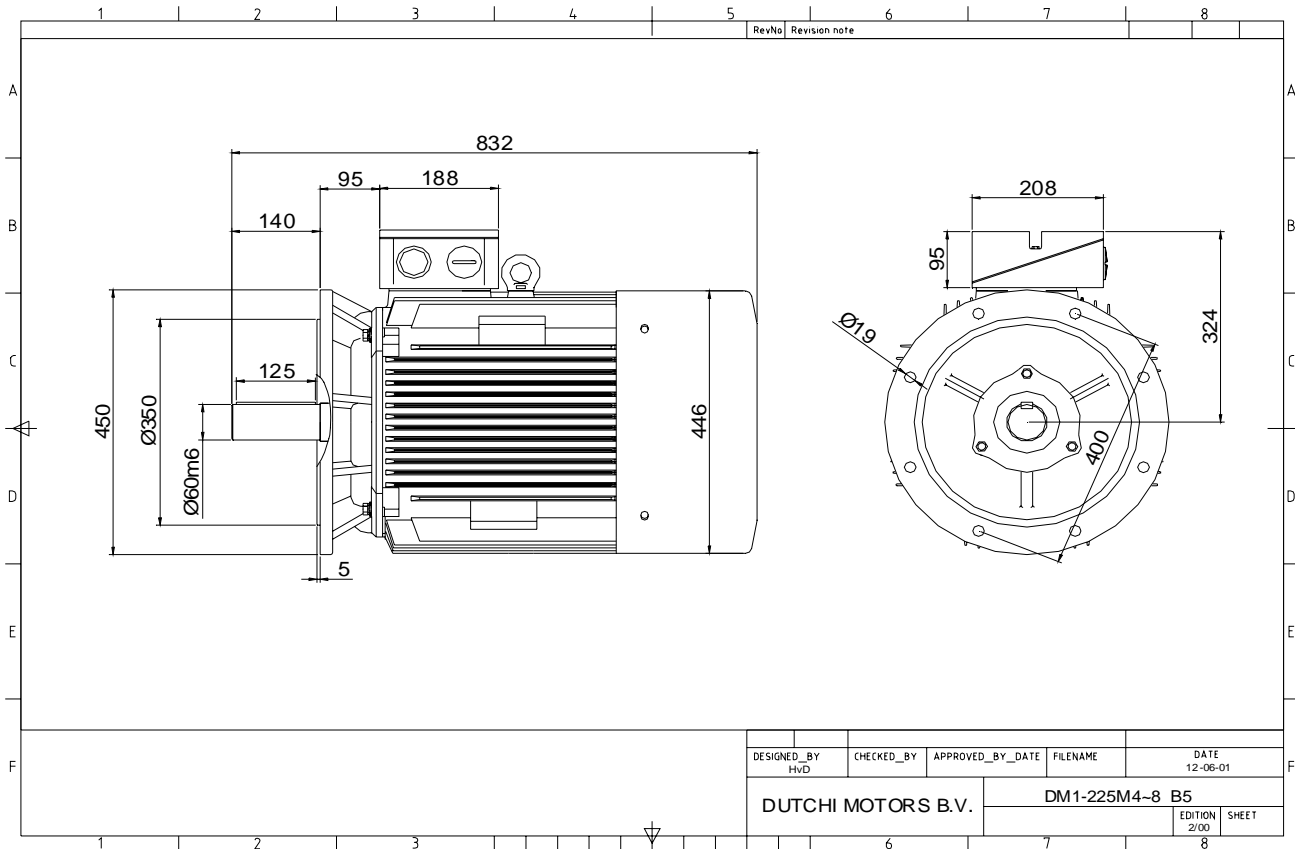

Specification **IEC 60034-1**
 Manufacturer **Dutchi Motors B.V.**
 Motor type **DM1- 225 M8**
 Rated power **22** kW **S1** duty
 Speed **730** r.p.m
 Voltage **400 / 690** V
 Frequency **50** Hz
 Connection **Δ / Y**
 Amps full load **43,6 / 25,2** A
 Amps no-load(400V) **21,90** A
 Enclosure **IP 55**
 Insulation Class **F (temp. rise B (80 K))**

Max. coolant temp. **40°C**
 Max. altitude **1.000** mtr, above sea level
 Comment **3 x PTC 150°C**
 Cable entries **2 x M50x1,5 + 1 x M20x1,5 (ptc)**

Feature **Cast-iron motor**
 Weight **294** kg
 Catalog no. **11538A22D**
 Warranty **12~18 months**

Efficiency class **N/A**
 Load data 100% 75% 50% 25%
 Efficiency **91,2 91,5 90,4 85,1** %
 Power factor **0,80 0,75 0,64 0,41**

Sound pressure level (1m) **61,3** dB(A)
 Resistance R20 (open) **0,351** Ω
 Resistance R20 **Δ 0,234** Ω

Full load torque **287,81** Nm
 DOL Starting torque vs FL torque **2,15**
 DOL Pull up torque vs FL torque **1,55**
 DOL Pull out torque vs FL torque **2,97**
 Star-Delta Starting torque vs FL torque **0,67**
 Star-Delta Pull up torque vs FL torque **0,48**
 Star-Delta Pull out torque vs FL torque **0,93**
 DOL Starting current vs FL current **7,09**
 Star Delta Starting current vs FL current **2,21**
 Rotor Inertia **0,5310** kgm²

Bearing DE **6313 - ZZ C3**
 Bearing NDE **6313 - ZZ C3**

WI	Change	date	sign.
Dutchi Motors B.V. P.O. Box 5390 NL-6802 EJ ARNHEM Tel : +31-(0)26 - 3541 600 Fax : +31-(0)26 - 3541 650		Discription Drawing made by :	date 27-04-04 sign. HvD
dutchi.motors@dutchi.nl www.dutchi.com			

Power is our commodity, the world is our market !

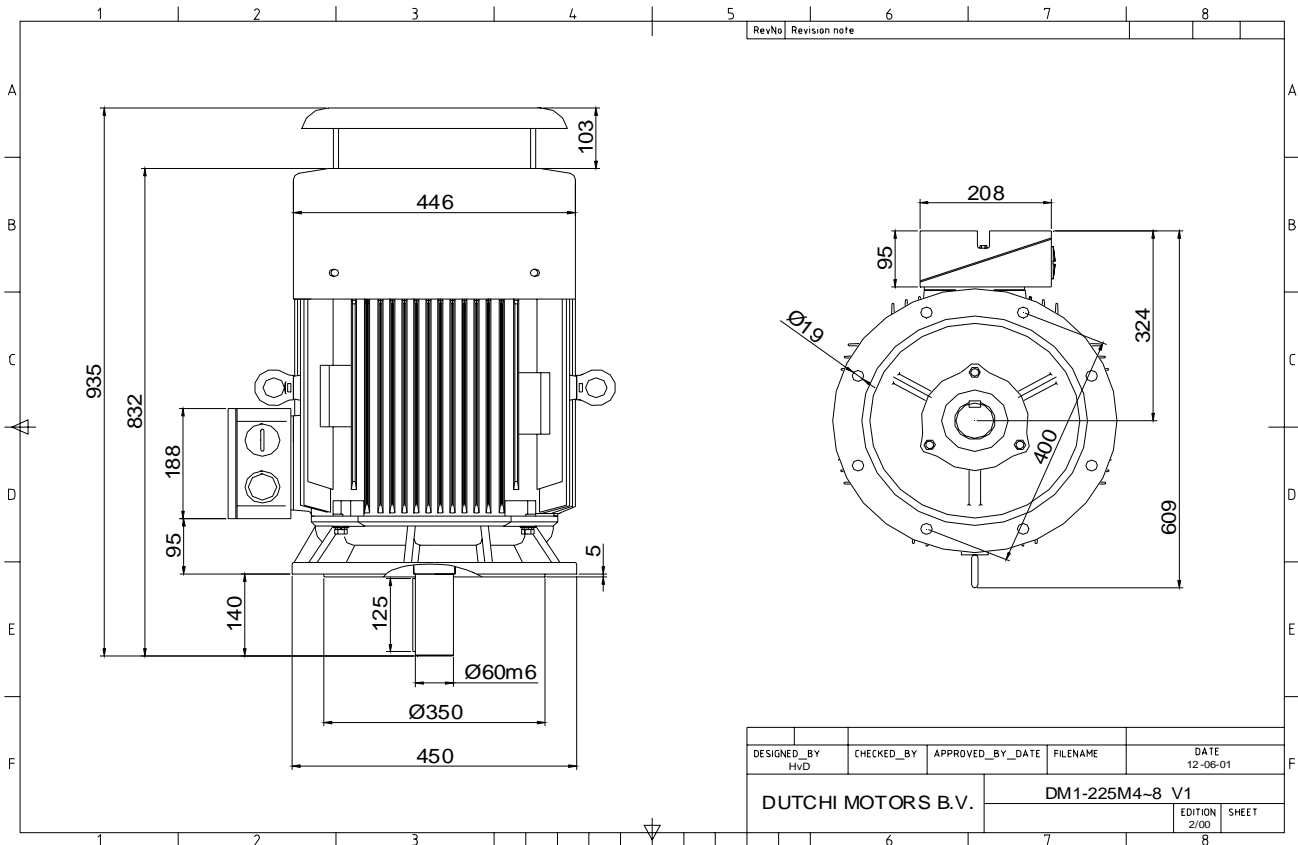

Specification **IEC 60034-1**
 Manufacturer **Dutchi Motors B.V.**
 Motor type **DM1- 225 M8**
 Rated power **22** kW **S1** duty
 Speed **730** r.p.m
 Voltage **400** / **690** V
 Frequency **50** Hz
 Connection **Δ** / **Y**
 Amps full load **43,6** / **25,2** A
 Amps no-load(400V) **21,90** A
 Enclosure **IP 55**
 Insulation Class **F (temp. rise B (80 K))**

Max. coolant temp. **40°C**
 Max. altitude **1.000** mtr, above sea level
 Comment **3 x PTC 150°C**
 Cable entries **2 x M50x1,5 + 1 x M20x1,5 (ptc)**

Feature **Cast-iron motor**
 Weight **294** kg
 Catalog no. **11038A22D**
 Warranty **12~18 months**

Efficiency class **N/A**
 Load data 100% 75% 50% 25%
 Efficiency **91,2 91,5 90,4 85,1** %
 Power factor **0,80 0,75 0,64 0,41**

Sound pressure level (1m) **61,3** dB(A)
 Resistance R20 (open) **0,351** Ω
 Resistance R20 **Δ 0,234** Ω

Full load torque **287,81** Nm
 DOL Starting torque vs FL torque **2,15**
 DOL Pull up torque vs FL torque **1,55**
 DOL Pull out torque vs FL torque **2,97**
 Star-Delta Starting torque vs FL torque **0,67**
 Star-Delta Pull up torque vs FL torque **0,48**
 Star-Delta Pull out torque vs FL torque **0,93**
 DOL Starting current vs FL current **7,09**
 Star Delta Starting current vs FL current **2,21**
 Rotor Inertia **0,5310** kgm²

Bearing DE **6313 - ZZ C3**
 Bearing NDE **6313 - ZZ C3**

WI	Change	date	sign.
Dutchi Motors B.V. P.O. Box 5390 NL-6802 EJ ARNHEM Tel : +31-(0)26 - 3541 600 Fax : +31-(0)26 - 3541 650		Discription Drawing made by : 27-04-04	date sign. HVD
dutchi.motors@dutchi.nl www.dutchi.com			