

Power is our commodity, the world is our market !

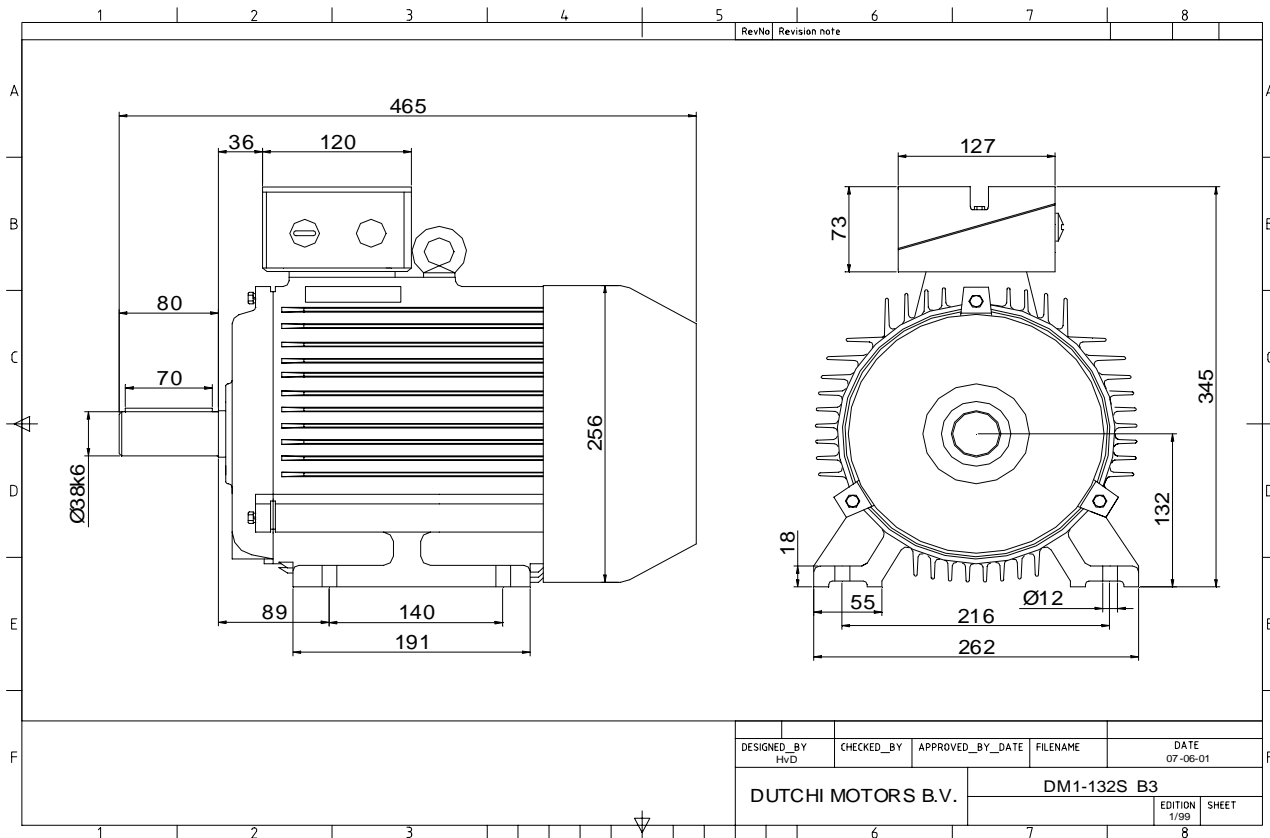

Specification **IEC 60034-1**
 Manufacturer **Dutchi Motors B.V.**
 Motor type **DM1- 132 S8**
 Rated power **2,2** kW **S1** duty
 Speed **710** r.p.m
 Voltage **230 / 400** V
 Frequency **50** Hz
 Connection **Δ / Y**
 Amps full load **9,87 / 5,70** A
 Amps no-load(400V) **4,10** A
 Enclosure **IP 55**
 Insulation Class **F (temp. rise B (80 K))**

Max. coolant temp. **40°C**
 Max. altitude **1.000** mtr, above sea level
 Comment **3 x PTC 150°C**
 Cable entries **2 x M32x1,5 + 1 x M20x1,5 (ptc)**

Feature **Cast-iron motor**
 Weight **62,0** kg
 Catalog no. **11128220D**
 Warranty **12~18 months**

Efficiency class **N/A**
 Load data 100% 75% 50% 25%
 Efficiency **77,7 76,8 73,3 62,0** %
 Power factor **0,72 0,62 0,49 0,33**

Sound pressure level (1m) **47,0** dB(A)
 Resistance R20 (open) **2,98** Ω
 Resistance R20 **Y 5,97** Ω

Full load torque **29,59** Nm
 DOL Starting torque vs FL torque **1,94**
 DOL Pull up torque vs FL torque **1,43**
 DOL Pull out torque vs FL torque **2,86**
 Star-Delta Starting torque vs FL torque **Y - motor**
 Star-Delta Pull up torque vs FL torque **Y - motor**
 Star-Delta Pull out torque vs FL torque **Y - motor**
 DOL Starting current vs FL current **5,16**
 Star Delta Starting current vs FL current **Y - motor**
 Rotor Inertia **0,0290** kgm²

Bearing DE **6308 - ZZ C3**
 Bearing NDE **6308 - ZZ C3**

WI	Change	date	sign.
Dutchi Motors B.V. P.O. Box 5390 NL-6802 EJ ARNHEM Tel : +31-(0)26 - 3541 600 Fax : +31-(0)26 - 3541 650		Description	date
		Drawing made by :	19-04-04
		dutchi.motors@dutchi.nl www.dutchi.com	

Power is our commodity, the world is our market !

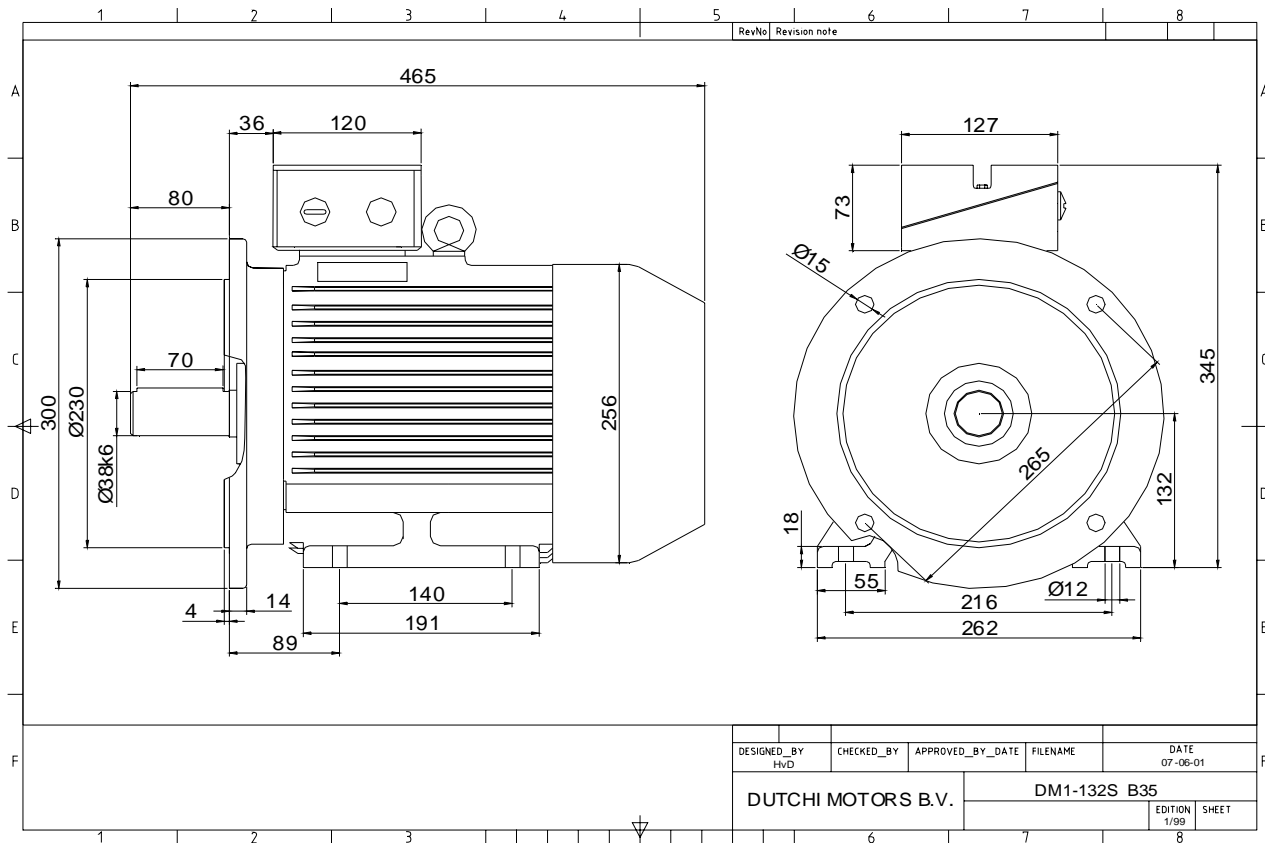

DESIGNED_BY HvD	CHECKED_BY	APPROVED_BY_DATE	FILENAME	DATE 07-06-01
DUTCHI MOTORS B.V.			DM1-132S B35	EDITION 1/99
				SHEET

Specification	IEC 60034-1
Manufacturer	Dutchi Motors B.V.
Motor type	DM1- 132 S8
Rated power	2,2 kW S1 duty
Speed	710 r.p.m
Voltage	230 / 400 V
Frequency	50 Hz
Connection	Δ / Y
Amps full load	9,87 / 5,70 A
Amps no-load(400V)	4,10 A
Enclosure	IP 55
Insulation Class	F (temp. rise B (80 K))
Max. coolant temp.	40°C
Max. altitude	1.000 mtr, above sea level
Comment	3 x PTC 150°C
Cable entries	2 x M32x1,5 + 1 x M20x1,5 (ptc)
Feature	Cast-iron motor
Weight	62,0 kg
Catalog no.	11528220D
Warranty	12~18 months

Efficiency class	N/A			
Load data	100%	75%	50%	25%
Efficiency	77,7	76,8	73,3	62,0 %
Power factor	0,72	0,62	0,49	0,33
Sound pressure level (1m)				47,0 dB(A)
Resistance R20 (open)				2,98 Ω
Resistance R20	Y		5,97	Ω
Full load torque				29,59 Nm
DOL Starting torque vs FL torque				1,94
DOL Pull up torque vs FL torque				1,43
DOL Pull out torque vs FL torque				2,86
Star-Delta Starting torque vs FL torque				Y - motor
Star-Delta Pull up torque vs FL torque				Y - motor
Star-Delta Pull out torque vs FL torque				Y - motor
DOL Starting current vs FL current				5,16
Star Delta Starting current vs FL current				Y - motor
Rotor Inertia				0,0290 kgm ²
Bearing DE				6308 - ZZ C3
Bearing NDE				6308 - ZZ C3

WI	Change	date	sign.
Dutchi Motors B.V. P.O. Box 5390 NL-6802 EJ ARNHEM Tel : +31-(0)26 - 3541 600 Fax : +31-(0)26 - 3541 650		Discription Drawing made by :	date sign. HvD
dutchi.motors@dutchi.nl www.dutchi.com		19-04-04	

Power is our commodity, the world is our market !

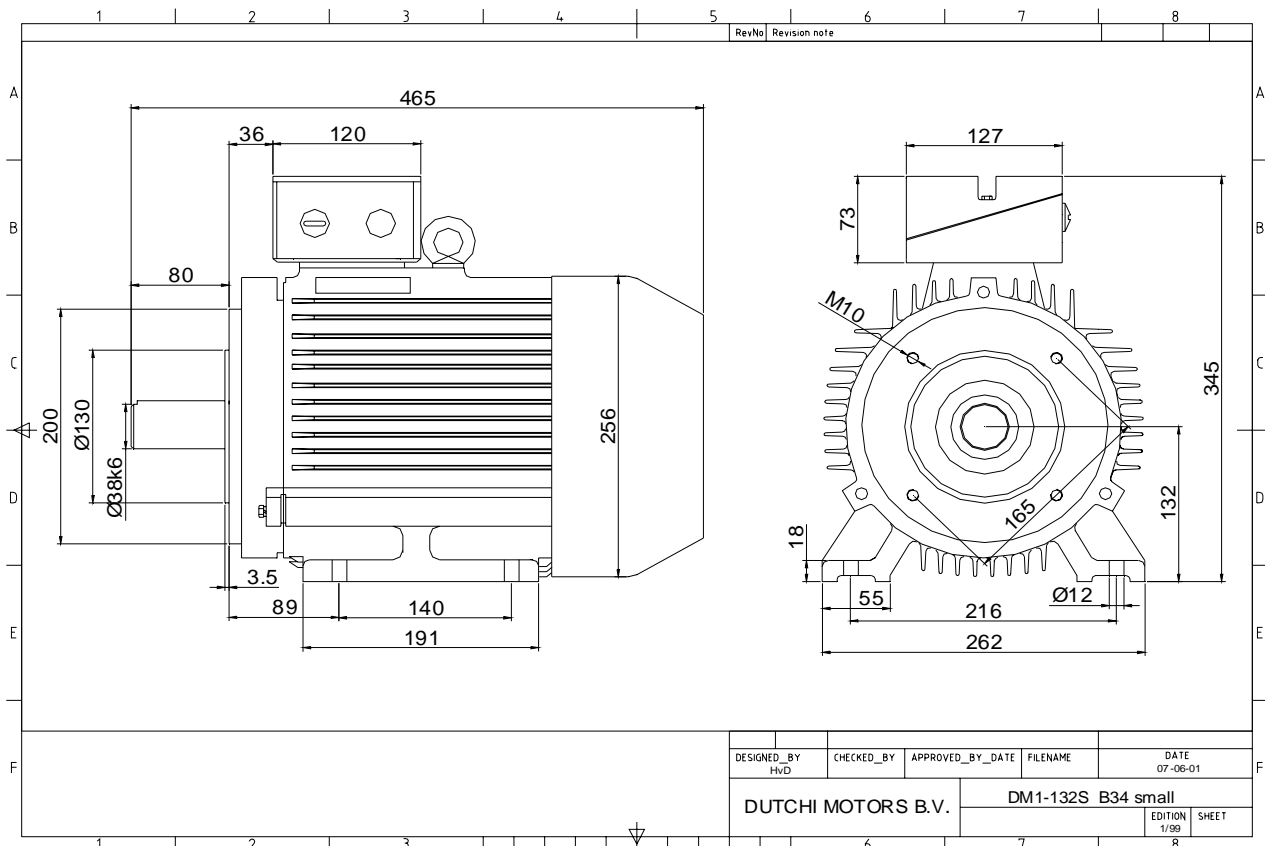

Specification **IEC 60034-1**
 Manufacturer **Dutchi Motors B.V.**
 Motor type **DM1- 132 S8**
 Rated power **2,2** kW **S1** duty
 Speed **710** r.p.m
 Voltage **230 / 400** V
 Frequency **50** Hz
 Connection **Δ / Y**
 Amps full load **9,87 / 5,70** A
 Amps no-load(400V) **4,10** A
 Enclosure **IP 55**
 Insulation Class **F (temp. rise B (80 K))**

Max. coolant temp. **40°C**
 Max. altitude **1.000** mtr, above sea level
 Comment **3 x PTC 150°C**
 Cable entries **2 x M32x1,5 + 1 x M20x1,5 (ptc)**

Feature **Cast-iron motor**
 Weight **62,0** kg
 Catalog no. **11628220D**
 Warranty **12~18 months**

Efficiency class **N/A**
 Load data 100% 75% 50% 25%
 Efficiency **77,7 76,8 73,3 62,0** %
 Power factor **0,72 0,62 0,49 0,33**

Sound pressure level (1m) **47,0** dB(A)
 Resistance R20 (open) **2,98** Ω
 Resistance R20 **Y 5,97** Ω

Full load torque **29,59** Nm
 DOL Starting torque vs FL torque **1,94**
 DOL Pull up torque vs FL torque **1,43**
 DOL Pull out torque vs FL torque **2,86**
 Star-Delta Starting torque vs FL torque **Y - motor**
 Star-Delta Pull up torque vs FL torque **Y - motor**
 Star-Delta Pull out torque vs FL torque **Y - motor**
 DOL Starting current vs FL current **5,16**
 Star Delta Starting current vs FL current **Y - motor**
 Rotor Inertia **0,0290** kgm²

Bearing DE **6308 - ZZ C3**
 Bearing NDE **6308 - ZZ C3**

WI	Change	date	sign.
Dutchi Motors B.V.		Description	date
P.O. Box 5390		Drawing made by :	19-04-04
NL-6802 EJ ARNHEM			
Tel : +31-(0)26 - 3541 600		dutchi.motors@dutchi.nl	
Fax : +31-(0)26 - 3541 650		www.dutchi.com	

Power is our commodity, the world is our market !

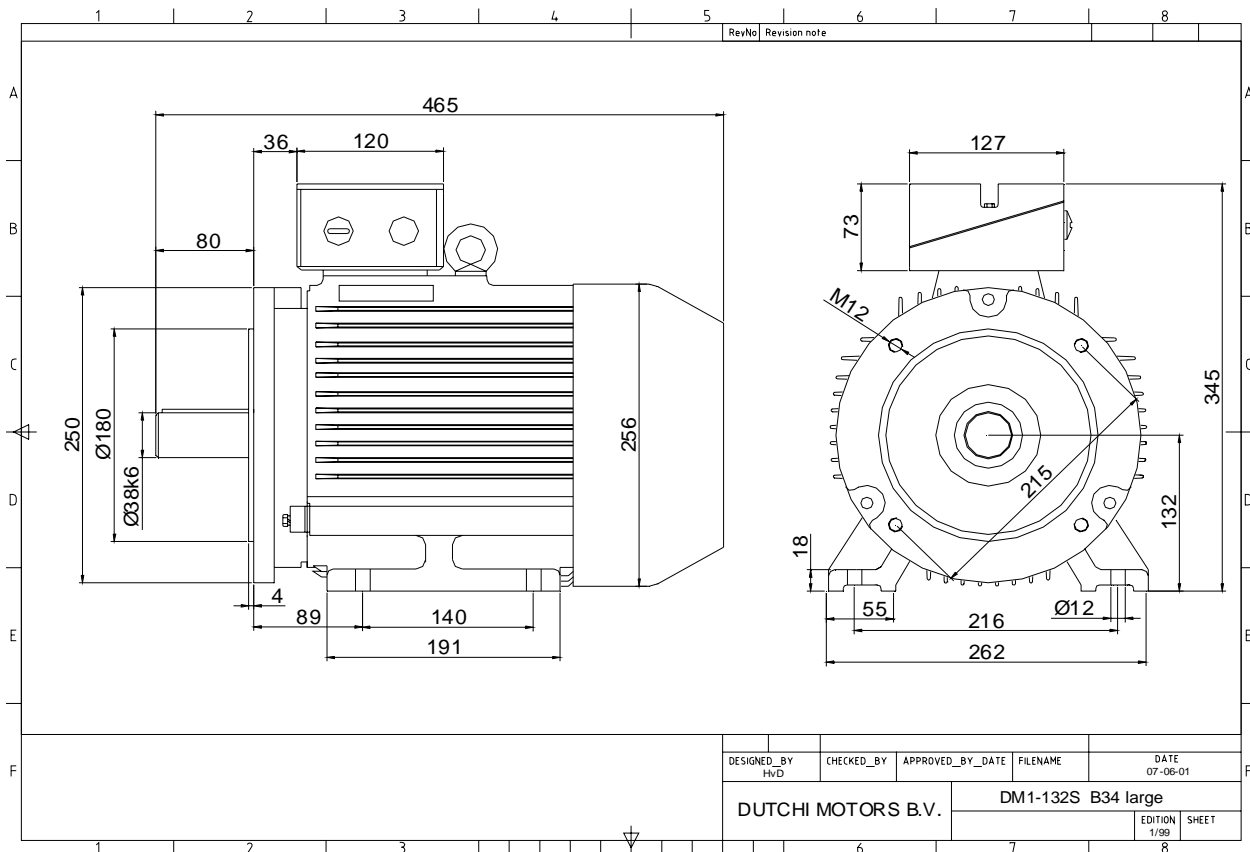

Specification **IEC 60034-1**
 Manufacturer **Dutchi Motors B.V.**
 Motor type **DM1- 132 S8**
 Rated power **2,2** kW **S1** duty
 Speed **710** r.p.m
 Voltage **230 / 400** V
 Frequency **50** Hz
 Connection **Δ / Y**
 Amps full load **9,87 / 5,70** A
 Amps no-load(400V) **4,10** A
 Enclosure **IP 55**
 Insulation Class **F (temp. rise B (80 K))**

Max. coolant temp. **40°C**
 Max. altitude **1.000** mtr, above sea level
 Comment **3 x PTC 150°C**
 Cable entries **2 x M32x1,5 + 1 x M20x1,5 (ptc)**

Feature **Cast-iron motor**
 Weight **62,0** kg
 Catalog no. **11728220D**
 Warranty **12~18 months**

Efficiency class **N/A**
 Load data 100% 75% 50% 25%
 Efficiency **77,7 76,8 73,3 62,0** %
 Power factor **0,72 0,62 0,49 0,33**

Sound pressure level (1m) **47,0** dB(A)
 Resistance R20 (open) **2,98** Ω
 Resistance R20 **Y 5,97** Ω

Full load torque **29,59** Nm
 DOL Starting torque vs FL torque **1,94**
 DOL Pull up torque vs FL torque **1,43**
 DOL Pull out torque vs FL torque **2,86**
 Star-Delta Starting torque vs FL torque **Y - motor**
 Star-Delta Pull up torque vs FL torque **Y - motor**
 Star-Delta Pull out torque vs FL torque **Y - motor**
 DOL Starting current vs FL current **5,16**
 Star Delta Starting current vs FL current **Y - motor**
 Rotor Inertia **0,0290** kgm2

Bearing DE **6308 - ZZ C3**
 Bearing NDE **6308 - ZZ C3**

WI	Change	date	sign.
Dutchi Motors B.V. P.O. Box 5390 NL-6802 EJ ARNHEM Tel : +31-(0)26 - 3541 600 Fax : +31-(0)26 - 3541 650		Discription	date
		Drawing made by :	19-04-04
		sign.	HvD
		dutchi.motors@dutchi.nl www.dutchi.com	

Power is our commodity, the world is our market !

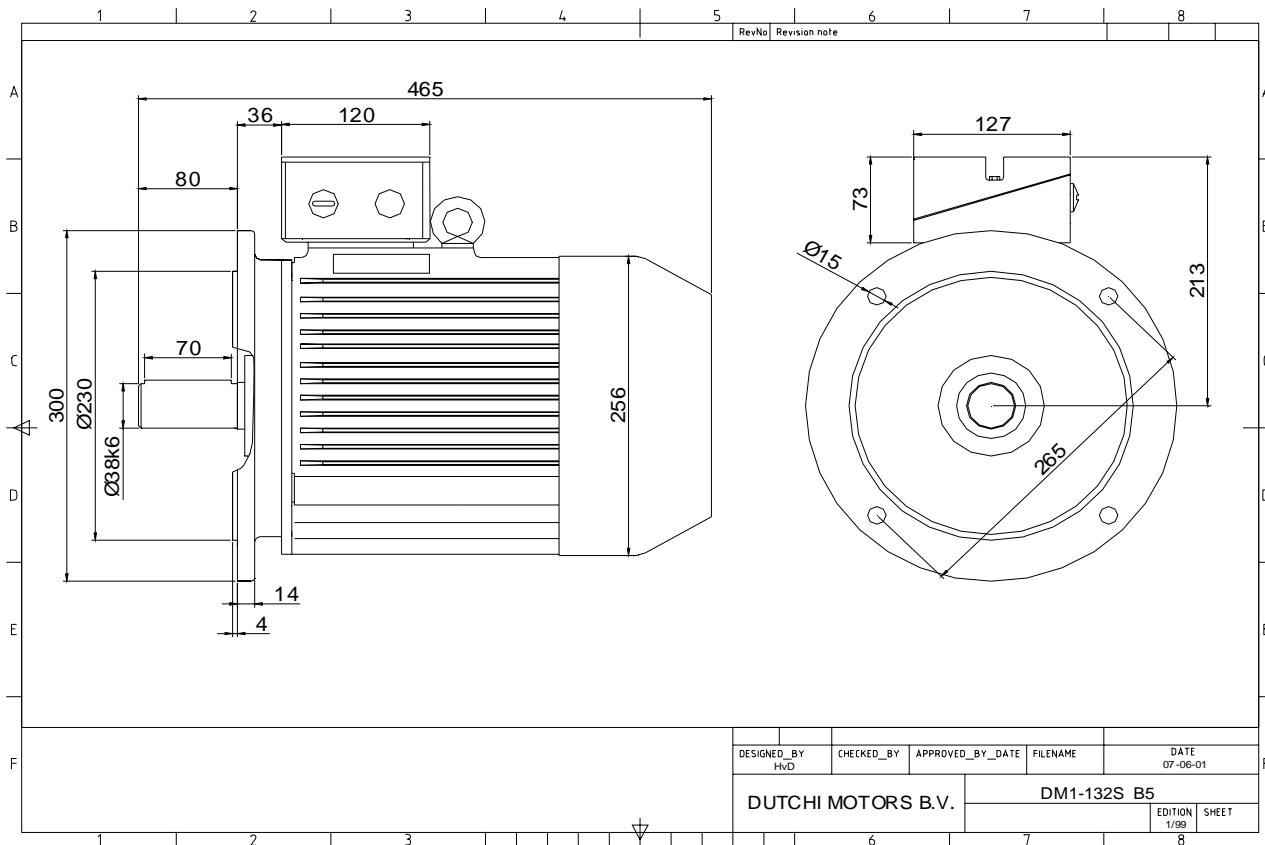

Specification **IEC 60034-1**
 Manufacturer **Dutchi Motors B.V.**
 Motor type **DM1- 132 S8**
 Rated power **2,2** kW **S1** duty
 Speed **710** r.p.m
 Voltage **230 / 400** V
 Frequency **50** Hz
 Connection **Δ / Y**
 Amps full load **9,87 / 5,70** A
 Amps no-load(400V) **4,10** A
 Enclosure **IP 55**
 Insulation Class **F (temp. rise B (80 K))**

Max. coolant temp. **40°C**
 Max. altitude **1.000** mtr, above sea level
 Comment **3 x PTC 150°C**
 Cable entries **2 x M32x1,5 + 1 x M20x1,5 (ptc)**

Feature **Cast-iron motor**
 Weight **62,0** kg
 Catalog no. **11228220D**
 Warranty **12~18 months**

Efficiency class **N/A**
 Load data 100% 75% 50% 25%
 Efficiency **77,7 76,8 73,3 62,0** %
 Power factor **0,72 0,62 0,49 0,33**

Sound pressure level (1m) **47,0** dB(A)
 Resistance R20 (open) **2,98** Ω
 Resistance R20 **Y 5,97** Ω

Full load torque **29,59** Nm
 DOL Starting torque vs FL torque **1,94**
 DOL Pull up torque vs FL torque **1,43**
 DOL Pull out torque vs FL torque **2,86**
 Star-Delta Starting torque vs FL torque **Y - motor**
 Star-Delta Pull up torque vs FL torque **Y - motor**
 Star-Delta Pull out torque vs FL torque **Y - motor**
 DOL Starting current vs FL current **5,16**
 Star Delta Starting current vs FL current **Y - motor**
 Rotor Inertia **0,0290** kgm²

Bearing DE **6308 - ZZ C3**
 Bearing NDE **6308 - ZZ C3**

WI	Change	date	sign.
Dutchi Motors B.V. P.O. Box 5390 NL-6802 EJ ARNHEM Tel : +31-(0)26 - 3541 600 Fax : +31-(0)26 - 3541 650		Discription Drawing made by :	date 19-04-04 sign. HVD
dutchi.motors@dutchi.nl www.dutchi.com			

Power is our commodity, the world is our market !

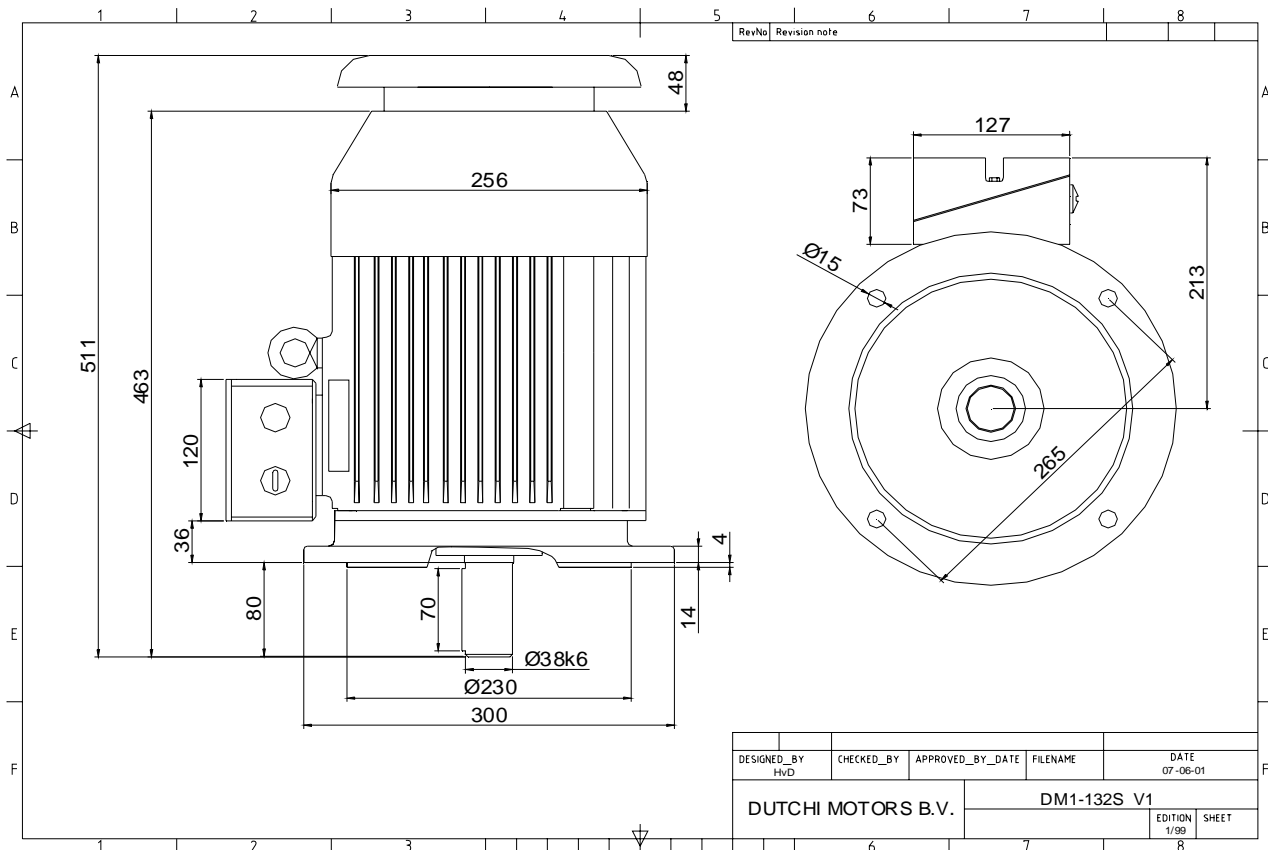

Specification **IEC 60034-1**
 Manufacturer **Dutchi Motors B.V.**
 Motor type **DM1- 132 S8**
 Rated power **2,2** kW **S1** duty
 Speed **710** r.p.m
 Voltage **230 / 400** V
 Frequency **50** Hz
 Connection **Δ / Y**
 Amps full load **9,87 / 5,70** A
 Amps no-load(400V) **4,10** A
 Enclosure **IP 55**
 Insulation Class **F (temp. rise B (80 K))**

Max. coolant temp. **40°C**
 Max. altitude **1.000** mtr, above sea level
 Comment **3 x PTC 150°C**
 Cable entries **2 x M32x1,5 + 1 x M20x1,5 (ptc)**

Feature **Cast-iron motor**
 Weight **62,0** kg
 Catalog no. **11028220D**
 Warranty **12~18 months**

Efficiency class **N/A**
 Load data 100% 75% 50% 25%
 Efficiency **77,7 76,8 73,3 62,0** %
 Power factor **0,72 0,62 0,49 0,33**

Sound pressure level (1m) **47,0** dB(A)
 Resistance R20 (open) **2,98** Ω
 Resistance R20 **Y 5,97** Ω

Full load torque **29,59** Nm
 DOL Starting torque vs FL torque **1,94**
 DOL Pull up torque vs FL torque **1,43**
 DOL Pull out torque vs FL torque **2,86**
 Star-Delta Starting torque vs FL torque **Y - motor**
 Star-Delta Pull up torque vs FL torque **Y - motor**
 Star-Delta Pull out torque vs FL torque **Y - motor**
 DOL Starting current vs FL current **5,16**
 Star Delta Starting current vs FL current **Y - motor**
 Rotor Inertia **0,0290** kgm²

Bearing DE **6308 - ZZ C3**
 Bearing NDE **6308 - ZZ C3**

WI	Change	date	sign.
Dutchi Motors B.V.		Description	date
P.O. Box 5390		Drawing made by :	19-04-04
NL-6802 EJ ARNHEM			HvD
Tel : +31-(0)26 - 3541 600		dutchi.motors@dutchi.nl	
Fax : +31-(0)26 - 3541 650		www.dutchi.com	

Power is our commodity, the world is our market !

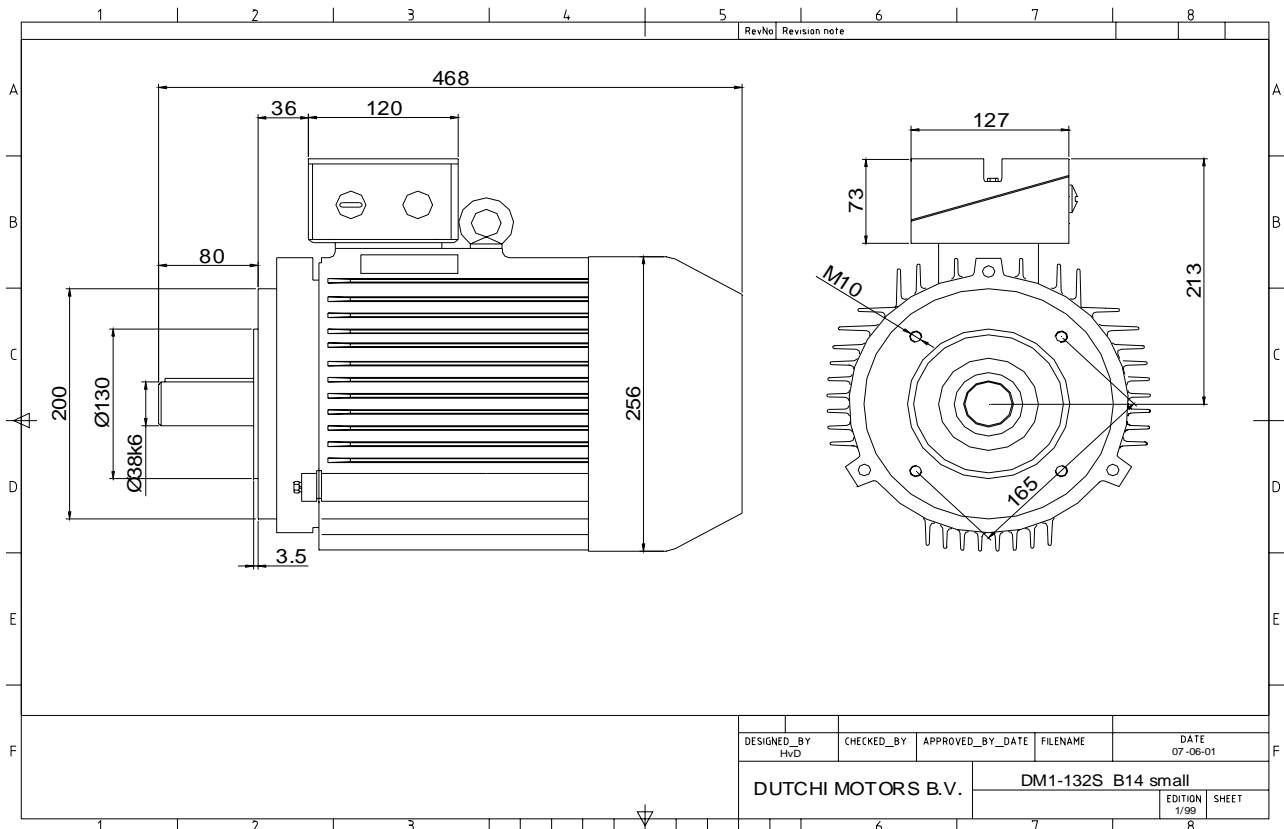

Specification **IEC 60034-1**
 Manufacturer **Dutchi Motors B.V.**
 Motor type **DM1- 132 S8**
 Rated power **2,2** kW **S1** duty
 Speed **710** r.p.m
 Voltage **230 / 400** V
 Frequency **50** Hz
 Connection **Δ / Y**
 Amps full load **9,87 / 5,70** A
 Amps no-load(400V) **4,10** A
 Enclosure **IP 55**
 Insulation Class **F (temp. rise B (80 K))**

Max. coolant temp. **40°C**
 Max. altitude **1.000** mtr, above sea level
 Comment **3 x PTC 150°C**
 Cable entries **2 x M32x1,5 + 1 x M20x1,5 (ptc)**

Feature **Cast-iron motor**
 Weight **62,0** kg
 Catalog no. **11328220D**
 Warranty **12~18 months**

Efficiency class **N/A**
 Load data 100% 75% 50% 25%
 Efficiency **77,7 76,8 73,3 62,0** %
 Power factor **0,72 0,62 0,49 0,33**

Sound pressure level (1m) **47,0** dB(A)
 Resistance R20 (open) **2,98** Ω
 Resistance R20 **Y 5,97** Ω

Full load torque **29,59** Nm
 DOL Starting torque vs FL torque **1,94**
 DOL Pull up torque vs FL torque **1,43**
 DOL Pull out torque vs FL torque **2,86**
 Star-Delta Starting torque vs FL torque **Y - motor**
 Star-Delta Pull up torque vs FL torque **Y - motor**
 Star-Delta Pull out torque vs FL torque **Y - motor**
 DOL Starting current vs FL current **5,16**
 Star Delta Starting current vs FL current **Y - motor**
 Rotor Inertia **0,0290** kgm²

Bearing DE **6308 - ZZ C3**
 Bearing NDE **6308 - ZZ C3**

WI	Change	date	sign.
Dutchi Motors B.V. P.O. Box 5390 NL-6802 EJ ARNHEM Tel : +31-(0)26 - 3541 600 Fax : +31-(0)26 - 3541 650		Description	date
		Drawing made by :	19-04-04
		dutchi.motors@dutchi.nl www.dutchi.com	

Power is our commodity, the world is our market !

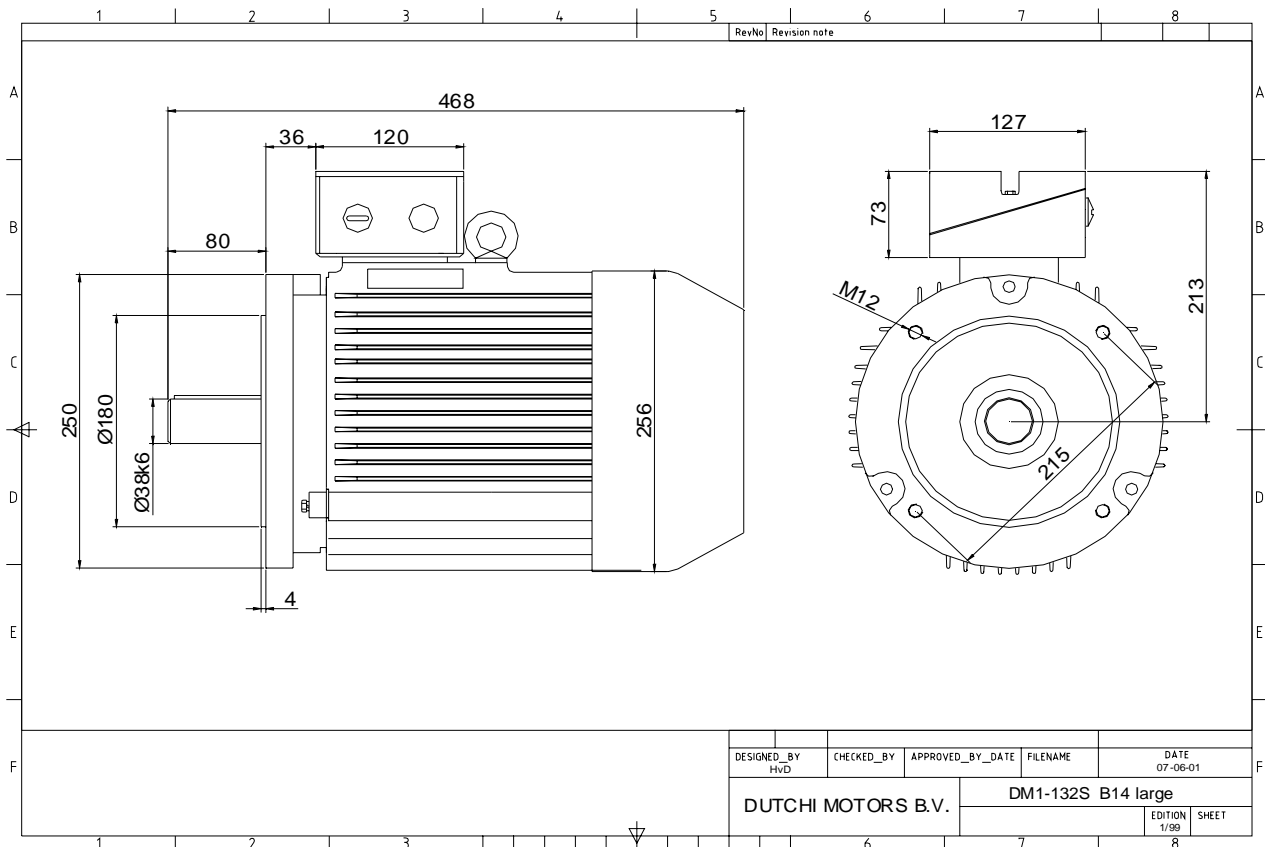

Specification **IEC 60034-1**
 Manufacturer **Dutchi Motors B.V.**
 Motor type **DM1- 132 S8**
 Rated power **2,2** kW **S1** duty
 Speed **710** r.p.m
 Voltage **230 / 400** V
 Frequency **50** Hz
 Connection **Δ / Y**
 Amps full load **9,87 / 5,70** A
 Amps no-load(400V) **4,10** A
 Enclosure **IP 55**
 Insulation Class **F (temp. rise B (80 K))**

Max. coolant temp. **40°C**
 Max. altitude **1.000** mtr, above sea level
 Comment **3 x PTC 150°C**
 Cable entries **2 x M32x1,5 + 1 x M20x1,5 (ptc)**

Feature **Cast-iron motor**
 Weight **62,0** kg
 Catalog no. **11428220D**
 Warranty **12~18 months**

Efficiency class **N/A**
 Load data 100% 75% 50% 25%
 Efficiency **77,7 76,8 73,3 62,0** %
 Power factor **0,72 0,62 0,49 0,33**

Sound pressure level (1m) **47,0** dB(A)
 Resistance R20 (open) **2,98** Ω
 Resistance R20 **Y 5,97** Ω

Full load torque **29,59** Nm
 DOL Starting torque vs FL torque **1,94**
 DOL Pull up torque vs FL torque **1,43**
 DOL Pull out torque vs FL torque **2,86**
 Star-Delta Starting torque vs FL torque **Y - motor**
 Star-Delta Pull up torque vs FL torque **Y - motor**
 Star-Delta Pull out torque vs FL torque **Y - motor**
 DOL Starting current vs FL current **5,16**
 Star Delta Starting current vs FL current **Y - motor**
 Rotor Inertia **0,0290** kgm2

Bearing DE **6308 - ZZ C3**
 Bearing NDE **6308 - ZZ C3**

WI	Change	date	sign.
Dutchi Motors B.V.		Description	date
P.O. Box 5390		Drawing made by :	19-04-04
NL-6802 EJ ARNHEM			sign.
Tel : +31-(0)26 - 3541 600		dutchi.motors@dutchi.nl	
Fax : +31-(0)26 - 3541 650		www.dutchi.com	