

Power is our commodity, the world is our market !

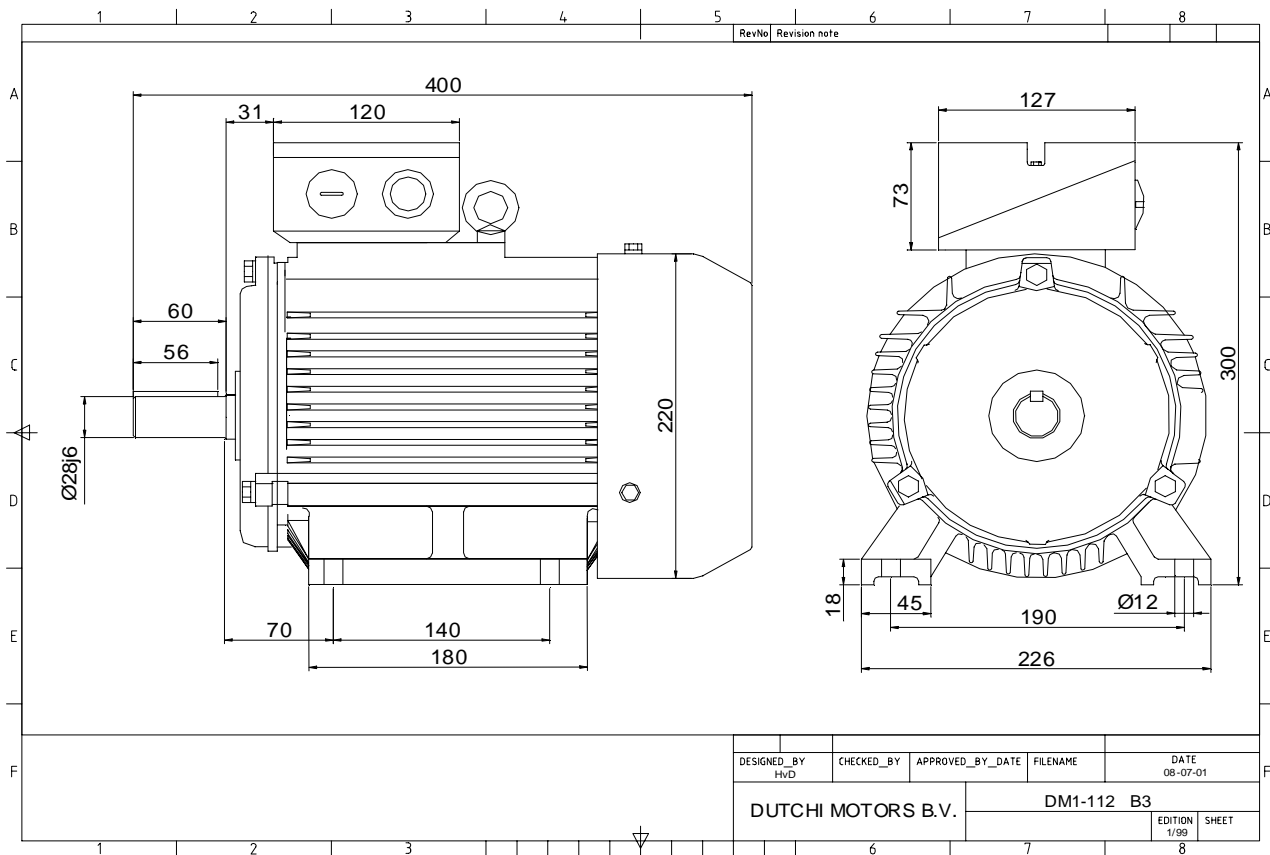

DESIGNED_BY HvD	CHECKED_BY	APPROVED_BY_DATE	FILENAME	DATE 08-07-01
DUTCHI MOTORS B.V.			DM1-112 B3	EDITION 1/99
				SHEET

Specification	<b>IEC 60034-1</b>
Manufacturer	<b>Dutchi Motors B.V.</b>
Motor type	<b>DM1- 112 M8</b>
Rated power	<b>1,5</b> kW <b>S1</b> duty
Speed	<b>730</b> r.p.m
Voltage	<b>230 / 400</b> V
Frequency	<b>50</b> Hz
Connection	<b>Δ / Y</b>
Amps full load	<b>7,26 / 4,19</b> A
Amps no-load(400V)	<b>3,20</b> A
Enclosure	<b>IP 55</b>
Insulation Class	<b>F (temp. rise B (80 K))</b>
Max. coolant temp.	<b>40°C</b>
Max. altitude	<b>1.000</b> mtr, above sea level
Comment	<b>3 x PTC 150°C</b>
Cable entries	<b>2 x M32x1,5 + 1 x M20x1,5 (ptc)</b>
Feature	<b>Cast-iron motor</b>
Weight	<b>39,0</b> kg
Catalog no.	<b>11128150D</b>
Warranty	<b>12~18 months</b>

Efficiency class	<b>N/A</b>			
Load data	100%	75%	50%	25%
Efficiency	<b>76,4</b>	<b>75,3</b>	<b>70,4</b>	<b>55,6</b> %
Power factor	<b>0,68</b>	<b>0,58</b>	<b>0,45</b>	<b>0,29</b>
Sound pressure level (1m)				<b>51,5</b> dB(A)
Resistance R20 (open)				<b>3,72</b> Ω
Resistance R20	<b>Y</b>		<b>7,43</b>	Ω
Full load torque				<b>19,62</b> Nm
DOL Starting torque vs FL torque				<b>2,28</b>
DOL Pull up torque vs FL torque				<b>1,64</b>
DOL Pull out torque vs FL torque				<b>3,08</b>
Star-Delta Starting torque vs FL torque				<b>Y - motor</b>
Star-Delta Pull up torque vs FL torque				<b>Y - motor</b>
Star-Delta Pull out torque vs FL torque				<b>Y - motor</b>
DOL Starting current vs FL current				<b>4,76</b>
Star Delta Starting current vs FL current				<b>Y - motor</b>
Rotor Inertia				<b>0,0138</b> kgm <sup>2</sup>
Bearing DE				<b>6306 - ZZ C3</b>
Bearing NDE				<b>6306 - ZZ C3</b>

Extras / Options :

WI	Change	date	sign.
<b>Dutchi Motors B.V.</b> P.O. Box 5390 NL-6802 EJ ARNHEM Tel : +31-(0)26 - 3541 600 Fax : +31-(0)26 - 3541 650		Discription Drawing made by :	date 19-04-04 sign. HvD
		<b>dutchi.motors@dutchi.nl</b> <b>www.dutchi.com</b>	

Power is our commodity, the world is our market !

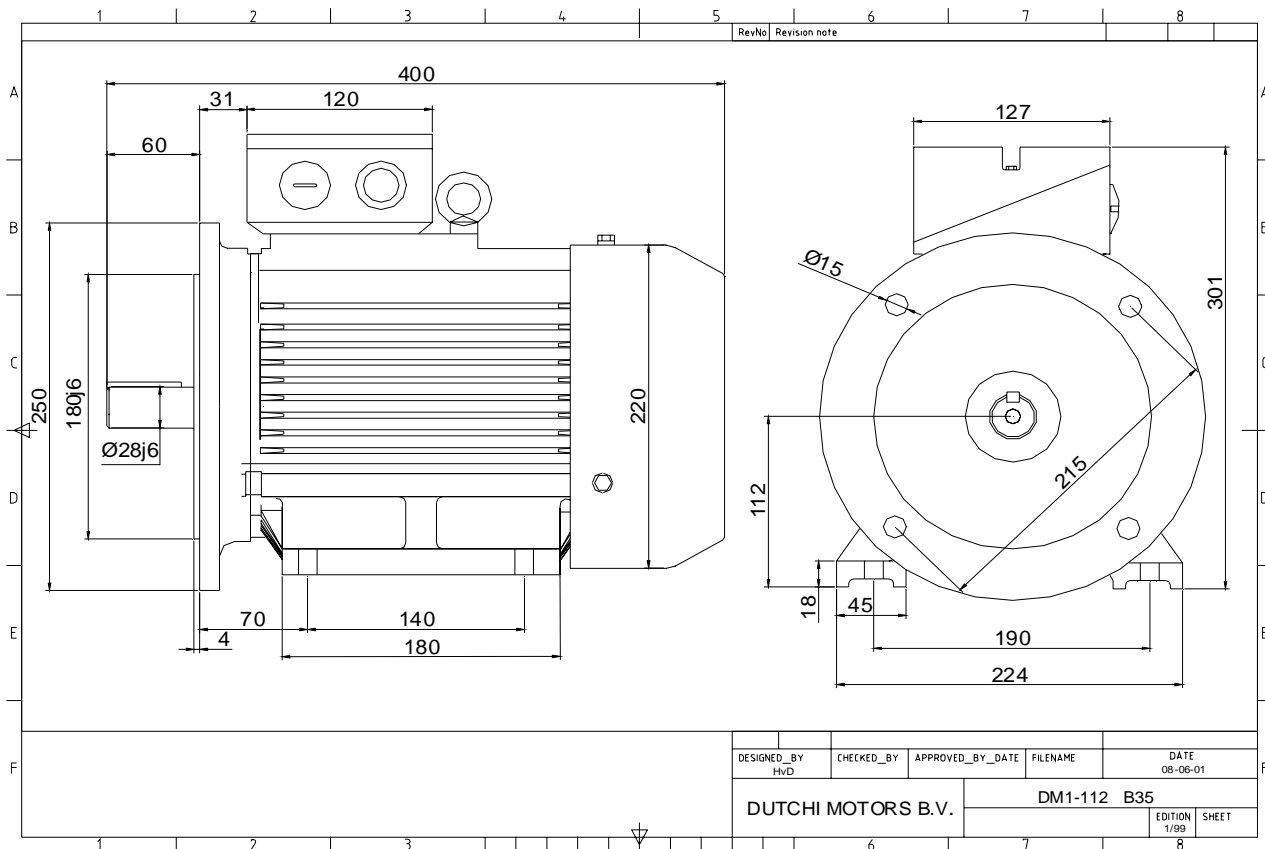

Specification **IEC 60034-1**  
 Manufacturer **Dutchi Motors B.V.**  
 Motor type **DM1- 112 M8**  
 Rated power **1,5** kW **S1** duty  
 Speed **730** r.p.m  
 Voltage **230 / 400** V  
 Frequency **50** Hz  
 Connection **Δ / Y**  
 Amps full load **7,26 / 4,19** A  
 Amps no-load(400V) **3,20** A  
 Enclosure **IP 55**  
 Insulation Class **F (temp. rise B (80 K))**

Max. coolant temp. **40°C**  
 Max. altitude **1.000** mtr, above sea level  
 Comment **3 x PTC 150°C**  
 Cable entries **2 x M32x1,5 + 1 x M20x1,5 (ptc)**

Feature **Cast-iron motor**  
 Weight **39,0** kg  
 Catalog no. **#N/B**  
 Warranty **12~18 months**

Efficiency class **N/A**  
 Load data 100% 75% 50% 25%  
 Efficiency **76,4 75,3 70,4 55,6** %  
 Power factor **0,68 0,58 0,45 0,29**

Sound pressure level (1m) **51,5** dB(A)  
 Resistance R20 (open) **3,72** Ω  
 Resistance R20 **Y 7,43** Ω

Full load torque **19,62** Nm  
 DOL Starting torque vs FL torque **2,28**  
 DOL Pull up torque vs FL torque **1,64**  
 DOL Pull out torque vs FL torque **3,08**  
 Star-Delta Starting torque vs FL torque **Y - motor**  
 Star-Delta Pull up torque vs FL torque **Y - motor**  
 Star-Delta Pull out torque vs FL torque **Y - motor**  
 DOL Starting current vs FL current **4,76**  
 Star Delta Starting current vs FL current **Y - motor**  
 Rotor Inertia **0,0138** kgm2

Bearing DE **6306 - ZZ C3**  
 Bearing NDE **6306 - ZZ C3**

Extras / Options :

WI	Change	date	sign.
Dutchi Motors B.V.		Description	date
P.O. Box 5390		Drawing made by :	19-04-04
NL-6802 EJ ARNHEM			
Tel : +31-(0)26 - 3541 600		dutchi.motors@dutchi.nl	
Fax : +31-(0)26 - 3541 650		www.dutchi.com	

Power is our commodity, the world is our market !

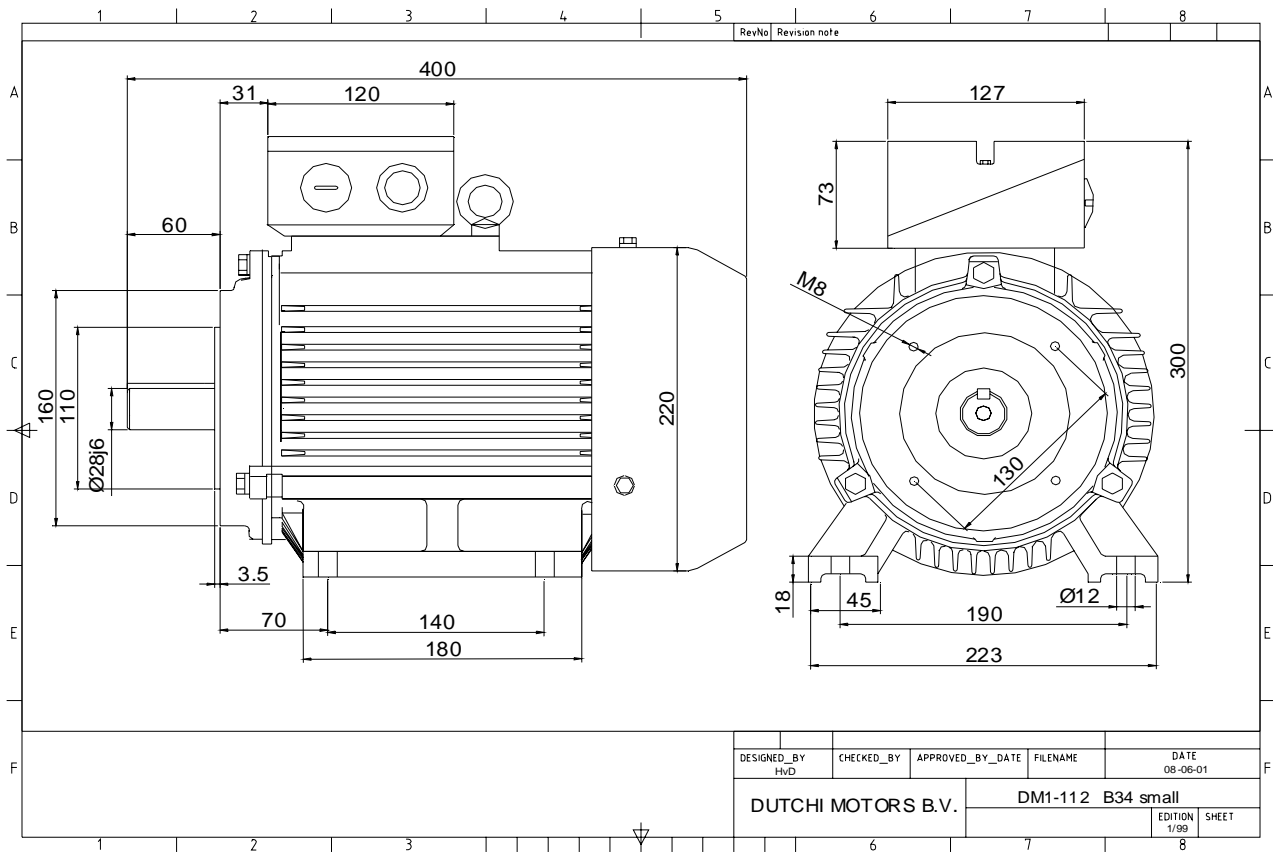

Specification **IEC 60034-1**  
 Manufacturer **Dutchi Motors B.V.**  
 Motor type **DM1- 112 M8**  
 Rated power **1,5** kW **S1** duty  
 Speed **730** r.p.m  
 Voltage **230 / 400** V  
 Frequency **50** Hz  
 Connection **Δ / Y**  
 Amps full load **7,26 / 4,19** A  
 Amps no-load(400V) **3,20** A  
 Enclosure **IP 55**  
 Insulation Class **F (temp. rise B (80 K))**

Max. coolant temp. **40°C**  
 Max. altitude **1.000** mtr, above sea level  
 Comment **3 x PTC 150°C**  
 Cable entries **2 x M32x1,5 + 1 x M20x1,5 (ptc)**

Feature **Cast-iron motor**  
 Weight **39,0** kg  
 Catalog no. **11628150D**  
 Warranty **12~18 months**

Efficiency class **N/A**  
 Load data 100% 75% 50% 25%  
 Efficiency **76,4 75,3 70,4 55,6** %  
 Power factor **0,68 0,58 0,45 0,29**

Sound pressure level (1m) **51,5** dB(A)  
 Resistance R20 (open) **3,72** Ω  
 Resistance R20 **Y 7,43** Ω

Full load torque **19,62** Nm  
 DOL Starting torque vs FL torque **2,28**  
 DOL Pull up torque vs FL torque **1,64**  
 DOL Pull out torque vs FL torque **3,08**  
 Star-Delta Starting torque vs FL torque **Y - motor**  
 Star-Delta Pull up torque vs FL torque **Y - motor**  
 Star-Delta Pull out torque vs FL torque **Y - motor**  
 DOL Starting current vs FL current **4,76**  
 Star Delta Starting current vs FL current **Y - motor**  
 Rotor Inertia **0,0138** kgm2

Bearing DE **6306 - ZZ C3**  
 Bearing NDE **6306 - ZZ C3**

Extras / Options :

WI	Change	date	sign.
<b>Dutchi Motors B.V.</b> P.O. Box 5390 NL-6802 EJ ARNHEM Tel : +31-(0)26 - 3541 600 Fax : +31-(0)26 - 3541 650		Description	date
		Drawing made by :	19-04-04
		dutchi.motors@dutchi.nl www.dutchi.com	

Power is our commodity, the world is our market !

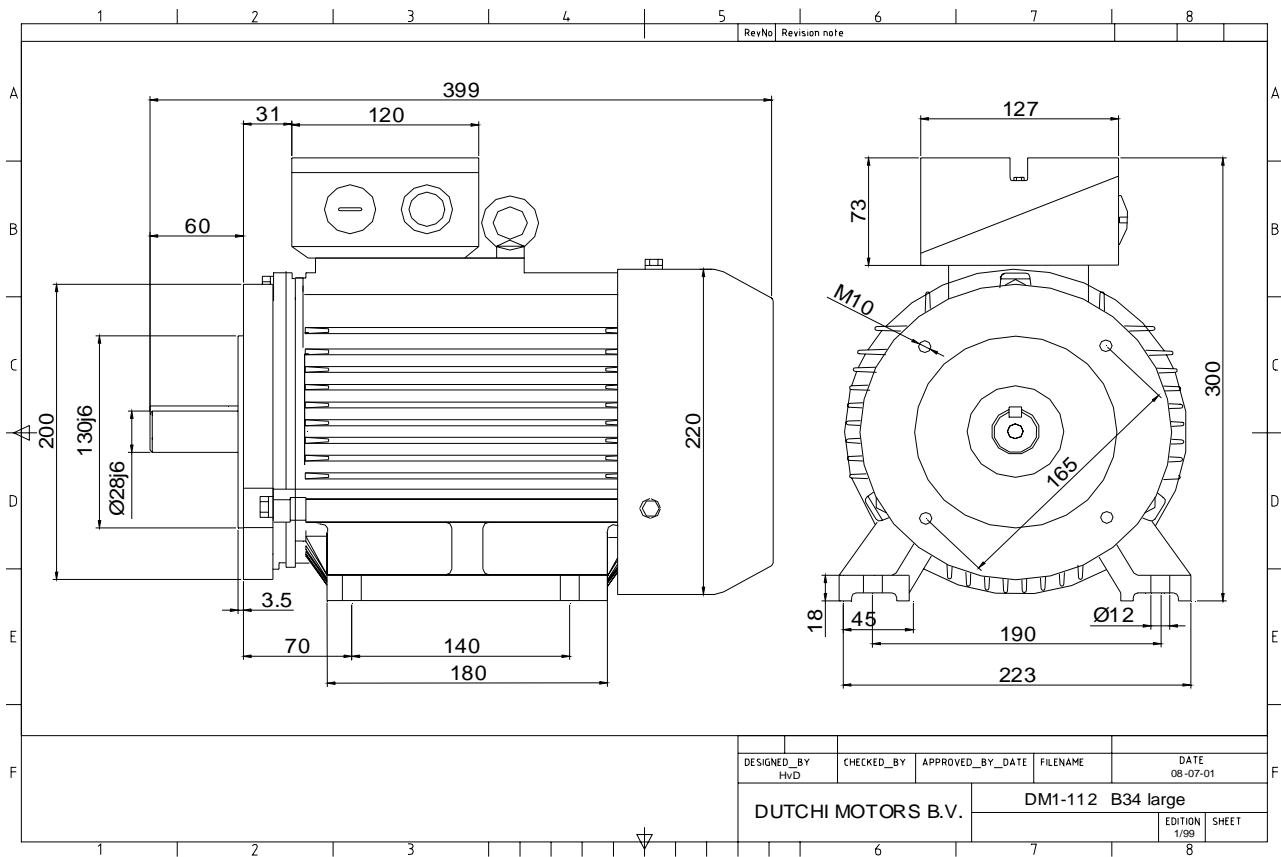

Specification **IEC 60034-1**  
 Manufacturer **Dutchi Motors B.V.**  
 Motor type **DM1- 112 M8**  
 Rated power **1,5** kW **S1** duty  
 Speed **730** r.p.m  
 Voltage **230 / 400** V  
 Frequency **50** Hz  
 Connection **Δ / Y**  
 Amps full load **7,26 / 4,19** A  
 Amps no-load(400V) **3,20** A  
 Enclosure **IP 55**  
 Insulation Class **F (temp. rise B (80 K))**

Max. coolant temp. **40°C**  
 Max. altitude **1.000** mtr, above sea level  
 Comment **3 x PTC 150°C**  
 Cable entries **2 x M32x1,5 + 1 x M20x1,5 (ptc)**

Feature **Cast-iron motor**  
 Weight **39,0** kg  
 Catalog no. **11728150D**  
 Warranty **12~18 months**

Efficiency class **N/A**  
 Load data 100% 75% 50% 25%  
 Efficiency **76,4 75,3 70,4 55,6** %  
 Power factor **0,68 0,58 0,45 0,29**

Sound pressure level (1m) **51,5** dB(A)  
 Resistance R20 (open) **3,72** Ω  
 Resistance R20 **Y 7,43** Ω

Full load torque **19,62** Nm  
 DOL Starting torque vs FL torque **2,28**  
 DOL Pull up torque vs FL torque **1,64**  
 DOL Pull out torque vs FL torque **3,08**  
 Star-Delta Starting torque vs FL torque **Y - motor**  
 Star-Delta Pull up torque vs FL torque **Y - motor**  
 Star-Delta Pull out torque vs FL torque **Y - motor**  
 DOL Starting current vs FL current **4,76**  
 Star Delta Starting current vs FL current **Y - motor**  
 Rotor Inertia **0,0138** kgm2

Bearing DE **6306 - ZZ C3**  
 Bearing NDE **6306 - ZZ C3**

Extras / Options :

WI	Change	date	sign.
<b>Dutchi Motors B.V.</b> P.O. Box 5390 NL-6802 EJ ARNHEM Tel : +31-(0)26 - 3541 600 Fax : +31-(0)26 - 3541 650		Description	date
		Drawing made by :	19-04-04
		dutchi.motors@dutchi.nl www.dutchi.com	

Power is our commodity, the world is our market !

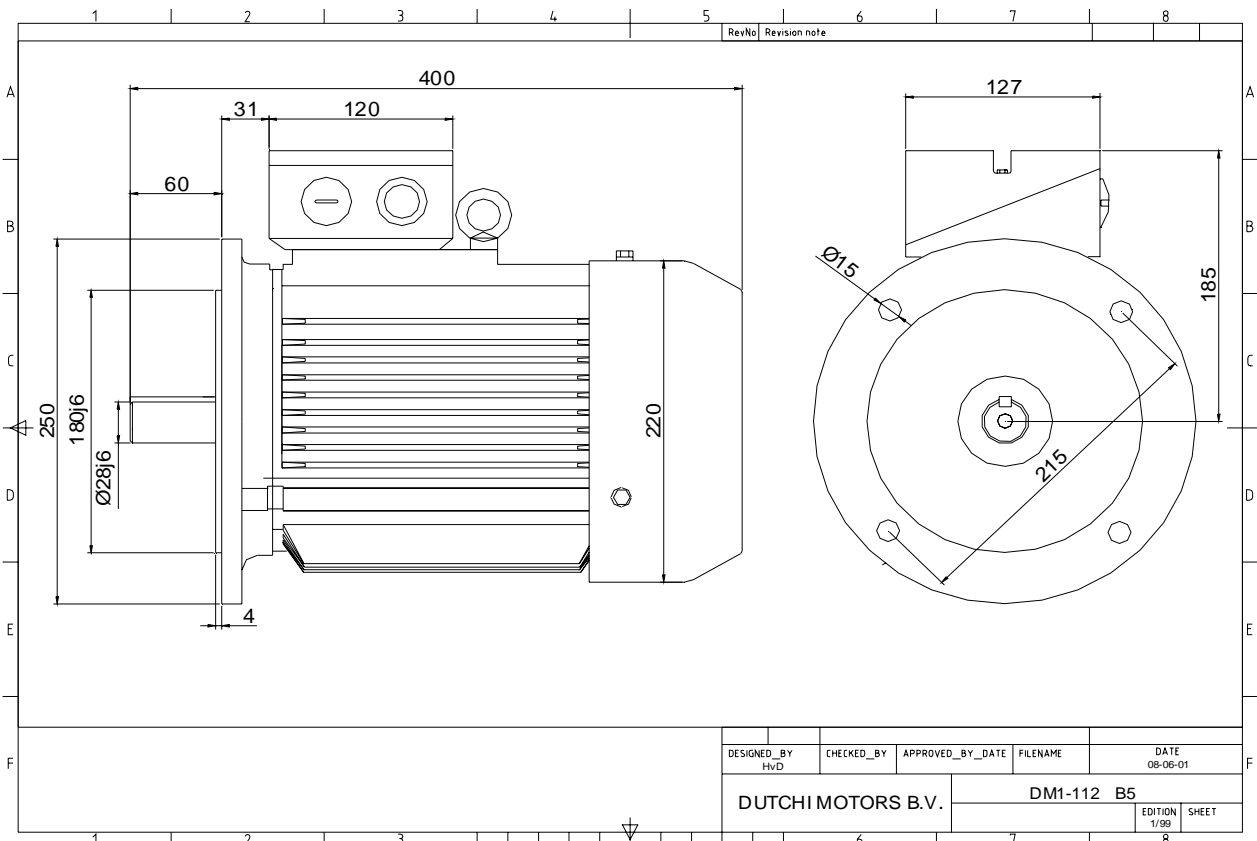

Specification **IEC 60034-1**  
 Manufacturer **Dutchi Motors B.V.**  
 Motor type **DM1- 112 M8**  
 Rated power **1,5** kW **S1** duty  
 Speed **730** r.p.m  
 Voltage **230 / 400** V  
 Frequency **50** Hz  
 Connection **Δ / Y**  
 Amps full load **7,26 / 4,19** A  
 Amps no-load(400V) **3,20** A  
 Enclosure **IP 55**  
 Insulation Class **F (temp. rise B (80 K))**

Max. coolant temp. **40°C**  
 Max. altitude **1.000** mtr, above sea level  
 Comment **3 x PTC 150°C**  
 Cable entries **2 x M32x1,5 + 1 x M20x1,5 (ptc)**

Feature **Cast-iron motor**  
 Weight **39,0** kg  
 Catalog no. **#N/B**  
 Warranty **12~18 months**

Efficiency class **N/A**  
 Load data 100% 75% 50% 25%  
 Efficiency **76,4 75,3 70,4 55,6** %  
 Power factor **0,68 0,58 0,45 0,29**

Sound pressure level (1m) **51,5** dB(A)  
 Resistance R20 (open) **3,72** Ω  
 Resistance R20 **Y 7,43** Ω

Full load torque **19,62** Nm  
 DOL Starting torque vs FL torque **2,28**  
 DOL Pull up torque vs FL torque **1,64**  
 DOL Pull out torque vs FL torque **3,08**  
 Star-Delta Starting torque vs FL torque **Y - motor**  
 Star-Delta Pull up torque vs FL torque **Y - motor**  
 Star-Delta Pull out torque vs FL torque **Y - motor**  
 DOL Starting current vs FL current **4,76**  
 Star Delta Starting current vs FL current **Y - motor**  
 Rotor Inertia **0,0138** kgm<sup>2</sup>

Bearing DE **6306 - ZZ C3**  
 Bearing NDE **6306 - ZZ C3**

Extras / Options :

WI	Change	date	sign.
Dutchi Motors B.V.		Description	date
P.O. Box 5390		Drawing made by :	19-04-04
NL-6802 EJ ARNHEM			
Tel : +31-(0)26 - 3541 600		<b>dutchi.motors@dutchi.nl</b>	
Fax : +31-(0)26 - 3541 650		<b>www.dutchi.com</b>	

Power is our commodity, the world is our market !

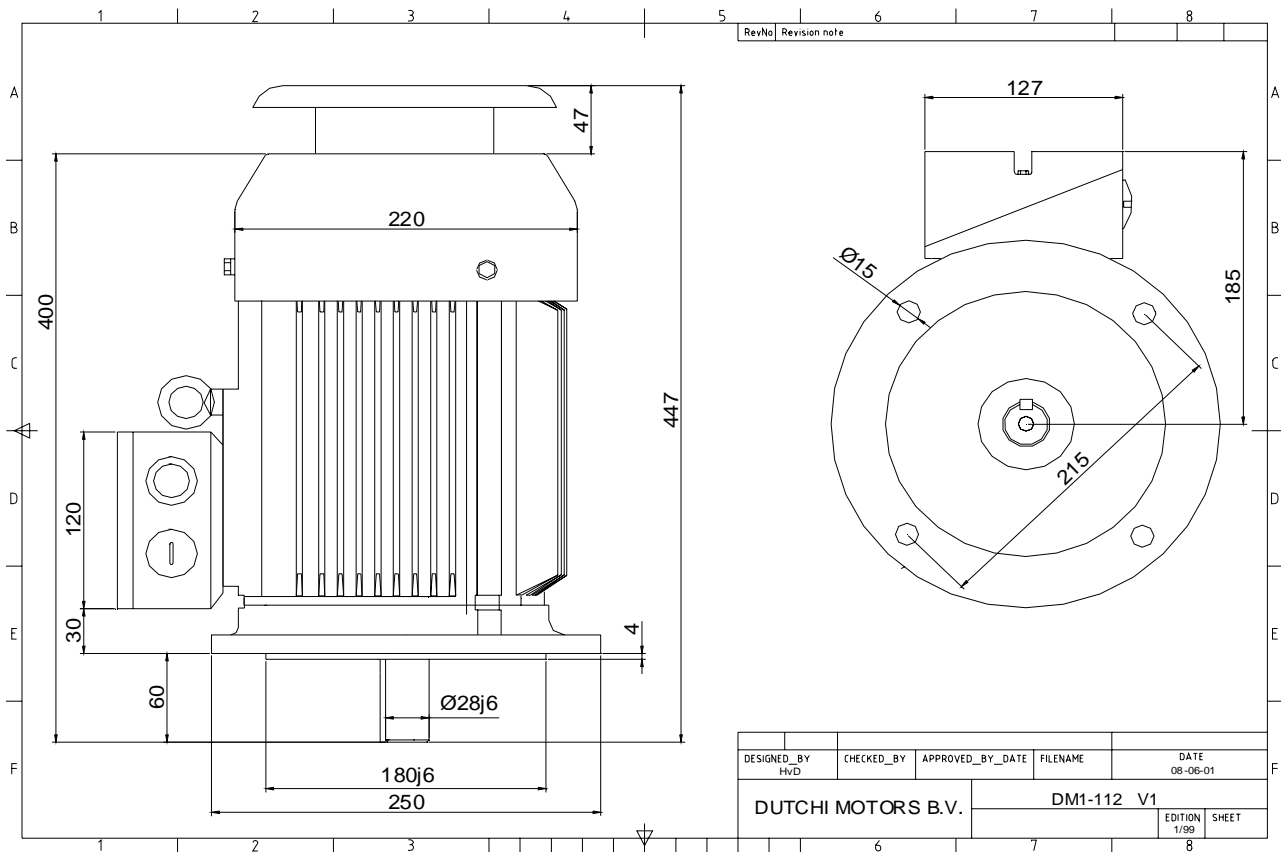

Specification **IEC 60034-1**  
 Manufacturer **Dutchi Motors B.V.**  
 Motor type **DM1- 112 M8**  
 Rated power **1,5** kW **S1** duty  
 Speed **730** r.p.m  
 Voltage **230** / **400** V  
 Frequency **50** Hz  
 Connection **Δ** / **Y**  
 Amps full load **7,26** / **4,19** A  
 Amps no-load(400V) **3,20** A  
 Enclosure **IP 55**  
 Insulation Class **F (temp. rise B (80 K))**

Max. coolant temp. **40°C**  
 Max. altitude **1.000** mtr, above sea level  
 Comment **3 x PTC 150°C**  
 Cable entries **2 x M32x1,5 + 1 x M20x1,5 (ptc)**

Feature **Cast-iron motor**  
 Weight **39,0** kg  
 Catalog no. **#N/B**  
 Warranty **12~18 months**

Efficiency class **N/A**  
 Load data 100% 75% 50% 25%  
 Efficiency **76,4 75,3 70,4 55,6** %  
 Power factor **0,68 0,58 0,45 0,29**

Sound pressure level (1m) **51,5** dB(A)  
 Resistance R20 (open) **3,72** Ω  
 Resistance R20 **Y 7,43** Ω

Full load torque **19,62** Nm  
 DOL Starting torque vs FL torque **2,28**  
 DOL Pull up torque vs FL torque **1,64**  
 DOL Pull out torque vs FL torque **3,08**  
 Star-Delta Starting torque vs FL torque **Y - motor**  
 Star-Delta Pull up torque vs FL torque **Y - motor**  
 Star-Delta Pull out torque vs FL torque **Y - motor**  
 DOL Starting current vs FL current **4,76**  
 Star Delta Starting current vs FL current **Y - motor**  
 Rotor Inertia **0,0138** kgm<sup>2</sup>

Bearing DE **6306 - ZZ C3**  
 Bearing NDE **6306 - ZZ C3**

Extras / Options :

WI	Change	date	sign.
Dutchi Motors B.V.		Description	date
P.O. Box 5390		Drawing made by :	19-04-04
NL-6802 EJ ARNHEM			
Tel : +31-(0)26 - 3541 600		dutchi.motors@dutchi.nl	
Fax : +31-(0)26 - 3541 650		www.dutchi.com	

Power is our commodity, the world is our market !

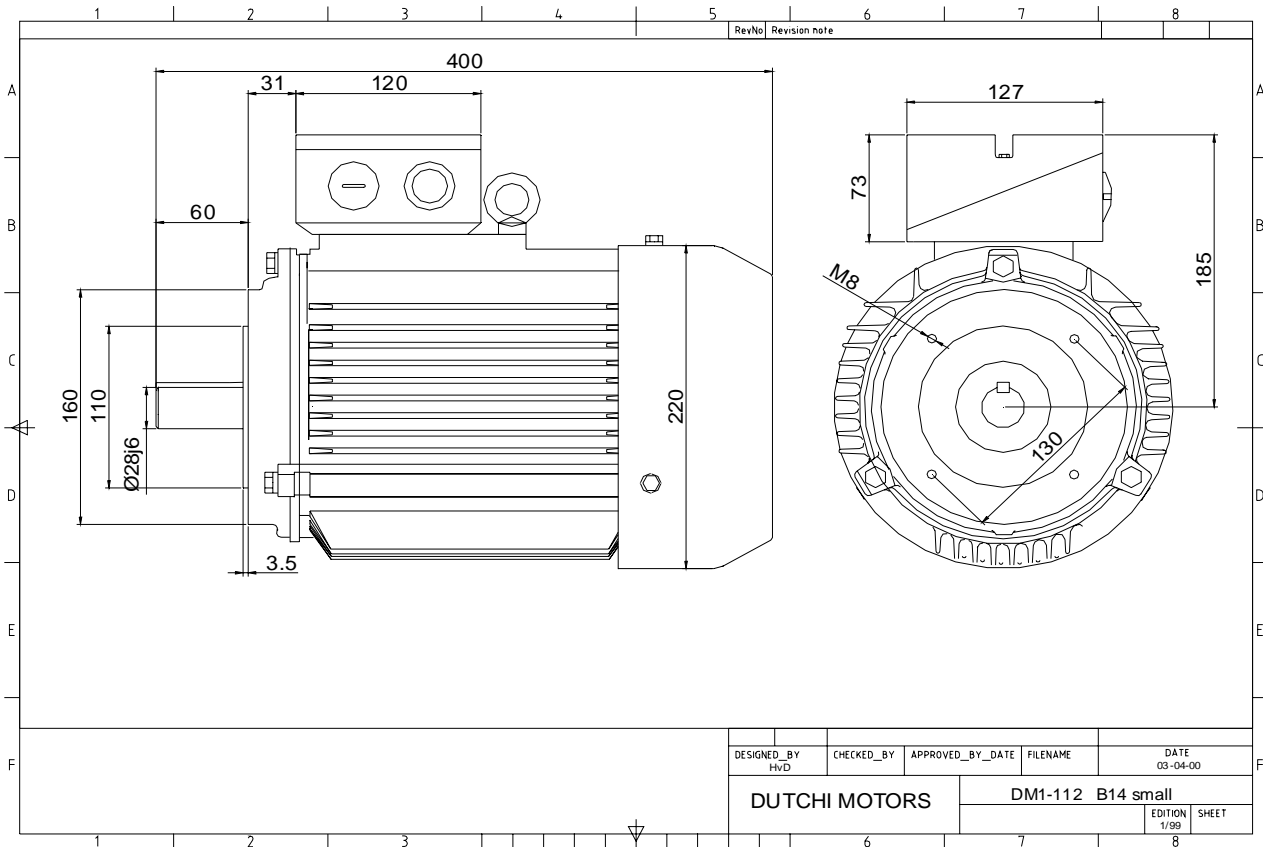

Specification **IEC 60034-1**  
 Manufacturer **Dutchi Motors B.V.**  
 Motor type **DM1- 112 M8**  
 Rated power **1,5** kW **S1** duty  
 Speed **730** r.p.m  
 Voltage **230 / 400** V  
 Frequency **50** Hz  
 Connection **Δ / Y**  
 Amps full load **7,26 / 4,19** A  
 Amps no-load(400V) **3,20** A  
 Enclosure **IP 55**  
 Insulation Class **F (temp. rise B (80 K))**

Max. coolant temp. **40°C**  
 Max. altitude **1.000** mtr, above sea level  
 Comment **3 x PTC 150°C**  
 Cable entries **2 x M32x1,5 + 1 x M20x1,5 (ptc)**

Feature **Cast-iron motor**  
 Weight **39,0** kg  
 Catalog no. **11328150D**  
 Warranty **12~18 months**

Efficiency class **N/A**  
 Load data 100% 75% 50% 25%  
 Efficiency **76,4 75,3 70,4 55,6** %  
 Power factor **0,68 0,58 0,45 0,29**

Sound pressure level (1m) **51,5** dB(A)  
 Resistance R20 (open) **3,72** Ω  
 Resistance R20 **Y 7,43** Ω

Full load torque **19,62** Nm  
 DOL Starting torque vs FL torque **2,28**  
 DOL Pull up torque vs FL torque **1,64**  
 DOL Pull out torque vs FL torque **3,08**  
 Star-Delta Starting torque vs FL torque **Y - motor**  
 Star-Delta Pull up torque vs FL torque **Y - motor**  
 Star-Delta Pull out torque vs FL torque **Y - motor**  
 DOL Starting current vs FL current **4,76**  
 Star Delta Starting current vs FL current **Y - motor**  
 Rotor Inertia **0,0138** kgm2

Bearing DE **6306 - ZZ C3**  
 Bearing NDE **6306 - ZZ C3**

Extras / Options :

WI	Change	date	sign.
<b>Dutchi Motors B.V.</b> P.O. Box 5390 NL-6802 EJ ARNHEM Tel : +31-(0)26 - 3541 600 Fax : +31-(0)26 - 3541 650		Description	date
		Drawing made by :	19-04-04
		dutchi.motors@dutchi.nl www.dutchi.com	

Power is our commodity, the world is our market !

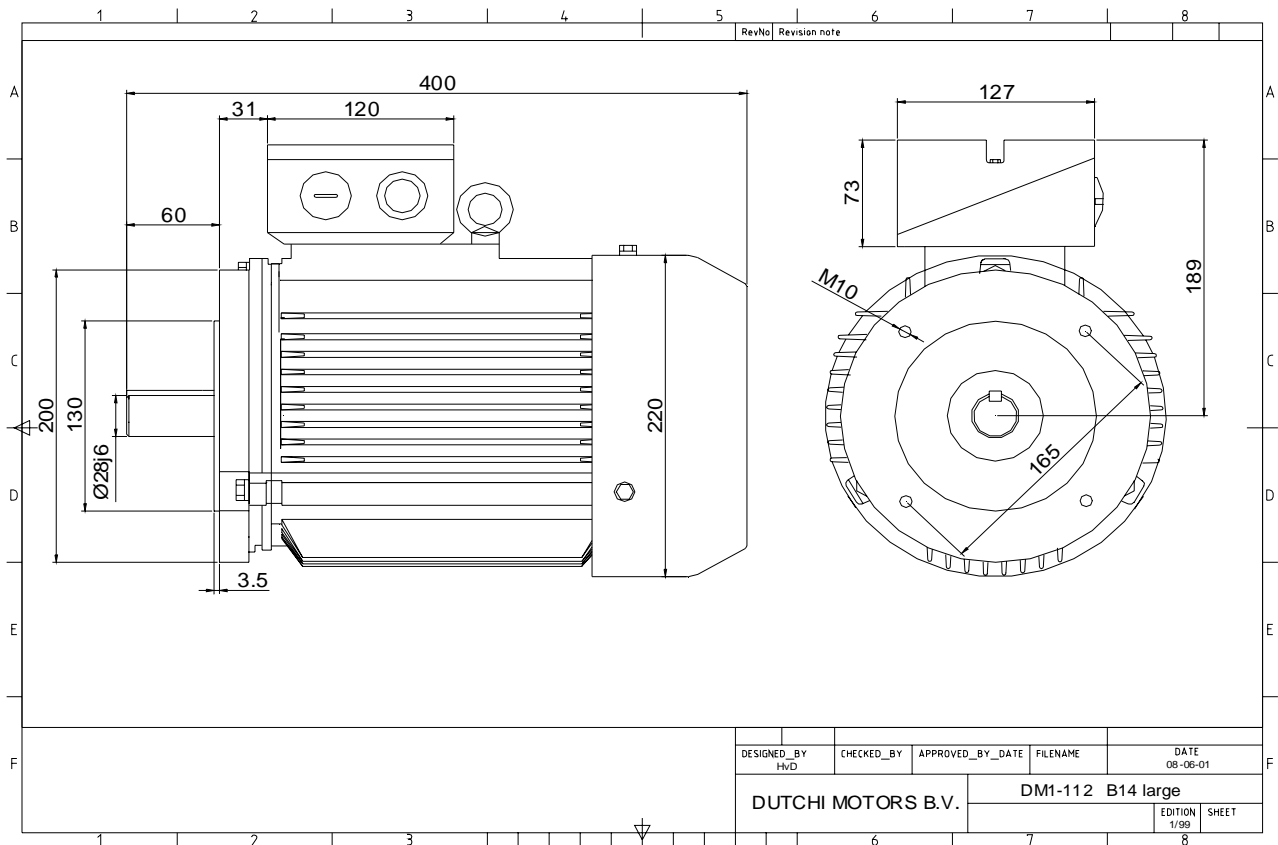

Specification **IEC 60034-1**  
 Manufacturer **Dutchi Motors B.V.**  
 Motor type **DM1- 112 M8**  
 Rated power **1,5** kW **S1** duty  
 Speed **730** r.p.m  
 Voltage **230 / 400** V  
 Frequency **50** Hz  
 Connection **Δ / Y**  
 Amps full load **7,26 / 4,19** A  
 Amps no-load(400V) **3,20** A  
 Enclosure **IP 55**  
 Insulation Class **F (temp. rise B (80 K))**

Max. coolant temp. **40°C**  
 Max. altitude **1.000** mtr, above sea level  
 Comment **3 x PTC 150°C**  
 Cable entries **2 x M32x1,5 + 1 x M20x1,5 (ptc)**

Feature **Cast-iron motor**  
 Weight **39,0** kg  
 Catalog no. **11428150D**  
 Warranty **12~18 months**

Efficiency class **N/A**  
 Load data 100% 75% 50% 25%  
 Efficiency **76,4 75,3 70,4 55,6** %  
 Power factor **0,68 0,58 0,45 0,29**

Sound pressure level (1m) **51,5** dB(A)  
 Resistance R20 (open) **3,72** Ω  
 Resistance R20 **Y 7,43** Ω

Full load torque **19,62** Nm  
 DOL Starting torque vs FL torque **2,28**  
 DOL Pull up torque vs FL torque **1,64**  
 DOL Pull out torque vs FL torque **3,08**  
 Star-Delta Starting torque vs FL torque **Y - motor**  
 Star-Delta Pull up torque vs FL torque **Y - motor**  
 Star-Delta Pull out torque vs FL torque **Y - motor**  
 DOL Starting current vs FL current **4,76**  
 Star Delta Starting current vs FL current **Y - motor**  
 Rotor Inertia **0,0138** kgm<sup>2</sup>

Bearing DE **6306 - ZZ C3**  
 Bearing NDE **6306 - ZZ C3**

Extras / Options :

WI	Change	date	sign.
<b>Dutchi Motors B.V.</b> P.O. Box 5390 NL-6802 EJ ARNHEM Tel : +31-(0)26 - 3541 600 Fax : +31-(0)26 - 3541 650		Description	date
		Drawing made by :	19-04-04
		<b>dutchi.motors@dutchi.nl</b> <b>www.dutchi.com</b>	