

Power is our commodity, the world is our market !

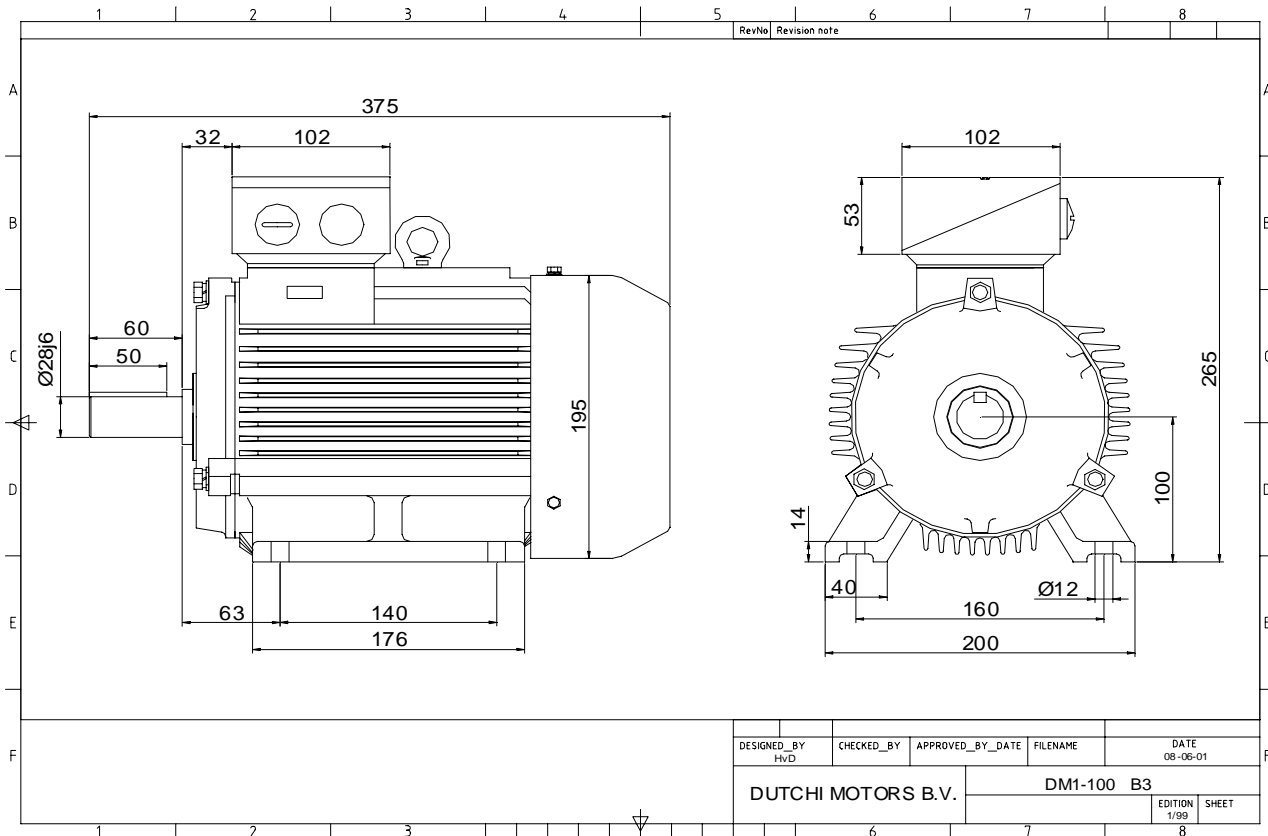

Specification **IEC 60034-1**
 Manufacturer **Dutchi Motors B.V.**
 Motor type **DM1- 100 L8**
 Rated power **0,75** kW **S1** duty
 Speed **705** r.p.m
 Voltage **230 / 400** V
 Frequency **50** Hz
 Connection **Δ / Y**
 Amps full load **4,19 / 2,42** A
 Amps no-load(400V) **2,02** A
 Enclosure **IP 55**
 Insulation Class **F (temp. rise B (80 K))**

Max. coolant temp. **40°C**
 Max. altitude **1.000** mtr, above sea level
 Comment **3 x PTC 150°C**
 Cable entries **2 x M25x1,5 + 1 x M20x1,5 (ptc)**

Feature **Cast-iron motor**
 Weight **33,0** kg
 Catalog no. **11128075D**
 Warranty **12~18 months**

Efficiency class **N/A**
 Load data 100% 75% 50% 25%
 Efficiency **68,8 66,6 60,1 44,1** %
 Power factor **0,65 0,55 0,43 0,30**

Sound pressure level (1m) **47,2** dB(A)
 Resistance R20 (open) **8,87** Ω
 Resistance R20 **Y 17,75** Ω

Full load torque **10,16** Nm
 DOL Starting torque vs FL torque **2,29**
 DOL Pull up torque vs FL torque **1,59**
 DOL Pull out torque vs FL torque **2,85**
 Star-Delta Starting torque vs FL torque **Y - motor**
 Star-Delta Pull up torque vs FL torque **Y - motor**
 Star-Delta Pull out torque vs FL torque **Y - motor**
 DOL Starting current vs FL current **3,87**
 Star Delta Starting current vs FL current **Y - motor**
 Rotor Inertia **0,0063** kgm²

Bearing DE **6206 - ZZ C3**
 Bearing NDE **6206 - ZZ C3**

WI	Change	date	sign.
Dutchi Motors B.V. P.O. Box 5390 NL-6802 EJ ARNHEM Tel : +31-(0)26 - 3541 600 Fax : +31-(0)26 - 3541 650		Discription Drawing made by :	date 19-04-04 sign. HvD
dutchi.motors@dutchi.nl www.dutchi.com			

Power is our commodity, the world is our market !

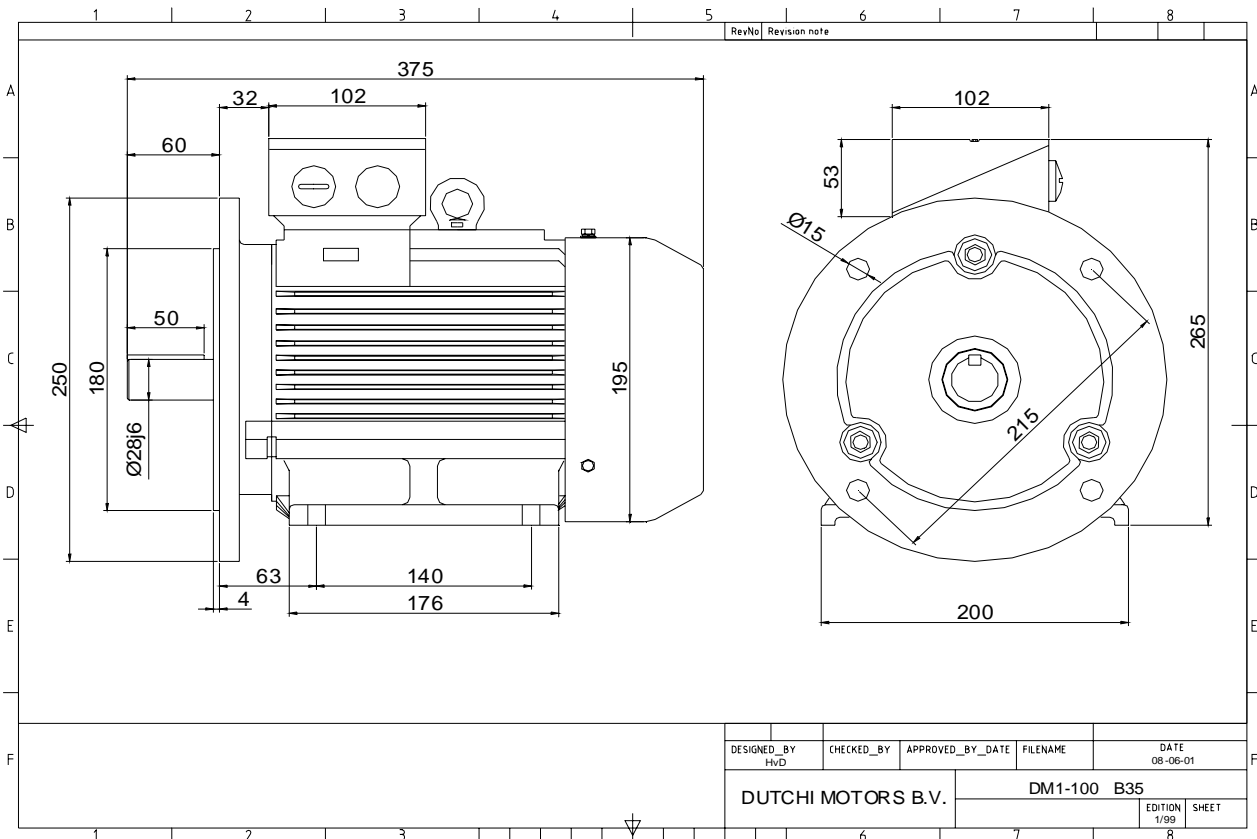

Specification	IEC 60034-1
Manufacturer	Dutchi Motors B.V.
Motor type	DM1- 100 L8
Rated power	0,75 kW S1 duty
Speed	705 r.p.m
Voltage	230 / 400 V
Frequency	50 Hz
Connection	Δ / Y
Amps full load	4,19 / 2,42 A
Amps no-load(400V)	2,02 A
Enclosure	IP 55
Insulation Class	F (temp. rise B (80 K))
Max. coolant temp.	40°C
Max. altitude	1.000 mtr, above sea level
Comment	3 x PTC 150°C
Cable entries	2 x M25x1,5 + 1 x M20x1,5 (ptc)
Feature	Cast-iron motor
Weight	33,0 kg
Catalog no.	11528075D
Warranty	12~18 months

Efficiency class	N/A			
Load data	100%	75%	50%	25%
Efficiency	68,8	66,6	60,1	44,1 %
Power factor	0,65	0,55	0,43	0,30
Sound pressure level (1m)				47,2 dB(A)
Resistance R20 (open)				8,87 Ω
Resistance R20	Y		17,75	Ω
Full load torque				10,16 Nm
DOL Starting torque vs FL torque				2,29
DOL Pull up torque vs FL torque				1,59
DOL Pull out torque vs FL torque				2,85
Star-Delta Starting torque vs FL torque				Y - motor
Star-Delta Pull up torque vs FL torque				Y - motor
Star-Delta Pull out torque vs FL torque				Y - motor
DOL Starting current vs FL current				3,87
Star Delta Starting current vs FL current				Y - motor
Rotor Inertia				0,0063 kgm ²
Bearing DE				6206 - ZZ C3
Bearing NDE				6206 - ZZ C3

WI	Change	date	sign.
Dutchi Motors B.V. P.O. Box 5390 NL-6802 EJ ARNHEM Tel : +31-(0)26 - 3541 600 Fax : +31-(0)26 - 3541 650		Discription Drawing made by :	date 19-04-04 sign. HvD
dutchi.motors@dutchi.nl www.dutchi.com			

Power is our commodity, the world is our market !

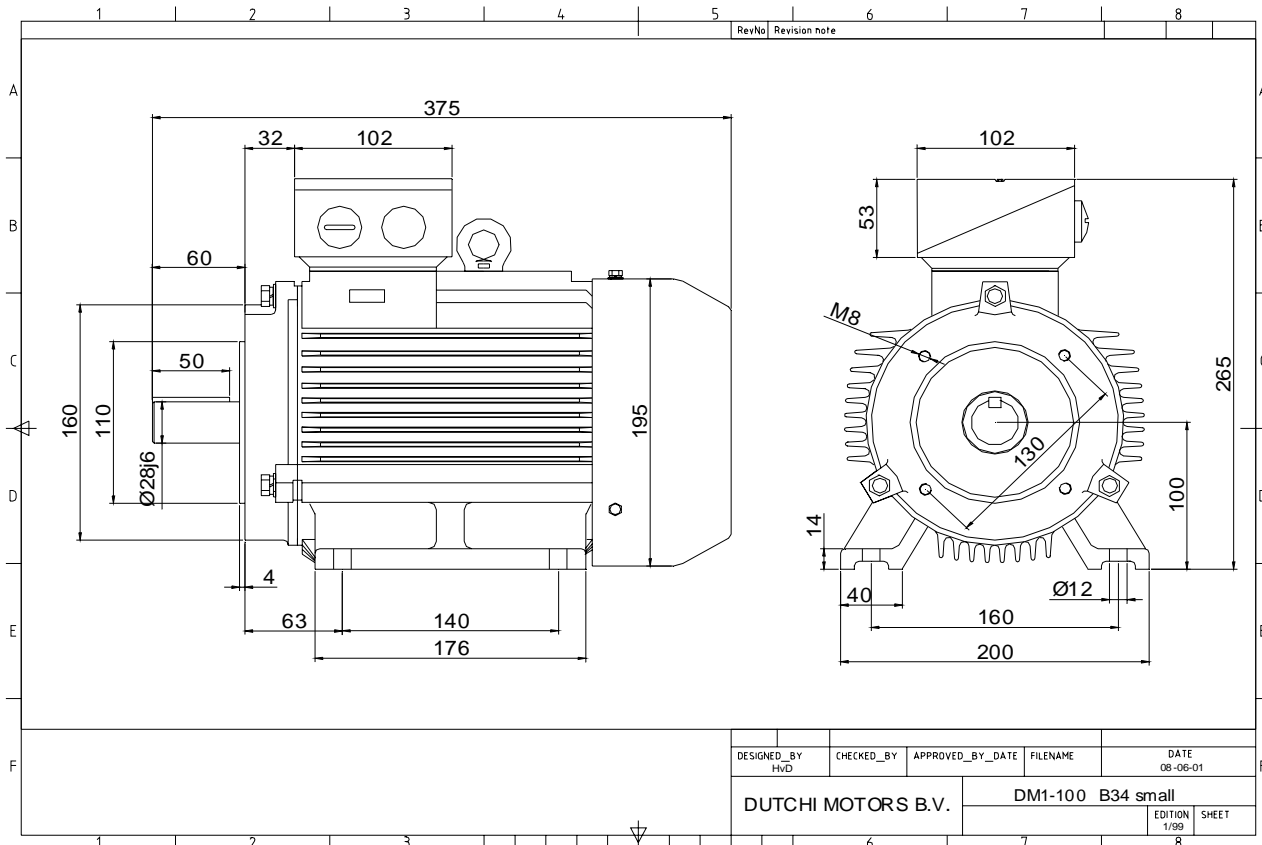

Specification	IEC 60034-1
Manufacturer	Dutchi Motors B.V.
Motor type	DM1- 100 L8
Rated power	0,75 kW S1 duty
Speed	705 r.p.m
Voltage	230 / 400 V
Frequency	50 Hz
Connection	Δ / Y
Amps full load	4,19 / 2,42 A
Amps no-load(400V)	2,02 A
Enclosure	IP 55
Insulation Class	F (temp. rise B (80 K))
Max. coolant temp.	40°C
Max. altitude	1.000 mtr, above sea level
Comment	3 x PTC 150°C
Cable entries	2 x M25x1,5 + 1 x M20x1,5 (ptc)
Feature	Cast-iron motor
Weight	33,0 kg
Catalog no.	11628075D
Warranty	12~18 months

Efficiency class	N/A			
Load data	100%	75%	50%	25%
Efficiency	68,8	66,6	60,1	44,1 %
Power factor	0,65	0,55	0,43	0,30
Sound pressure level (1m)				47,2 dB(A)
Resistance R20 (open)				8,87 Ω
Resistance R20	Y		17,75	Ω
Full load torque				10,16 Nm
DOL Starting torque vs FL torque				2,29
DOL Pull up torque vs FL torque				1,59
DOL Pull out torque vs FL torque				2,85
Star-Delta Starting torque vs FL torque				Y - motor
Star-Delta Pull up torque vs FL torque				Y - motor
Star-Delta Pull out torque vs FL torque				Y - motor
DOL Starting current vs FL current				3,87
Star Delta Starting current vs FL current				Y - motor
Rotor Inertia				0,0063 kgm ²
Bearing DE				6206 - ZZ C3
Bearing NDE				6206 - ZZ C3

WI	Change	date	sign.
Dutchi Motors B.V. P.O. Box 5390 NL-6802 EJ ARNHEM Tel : +31-(0)26 - 3541 600 Fax : +31-(0)26 - 3541 650		Description	date
		Drawing made by :	19-04-04
		dutchi.motors@dutchi.nl www.dutchi.com	

Power is our commodity, the world is our market !

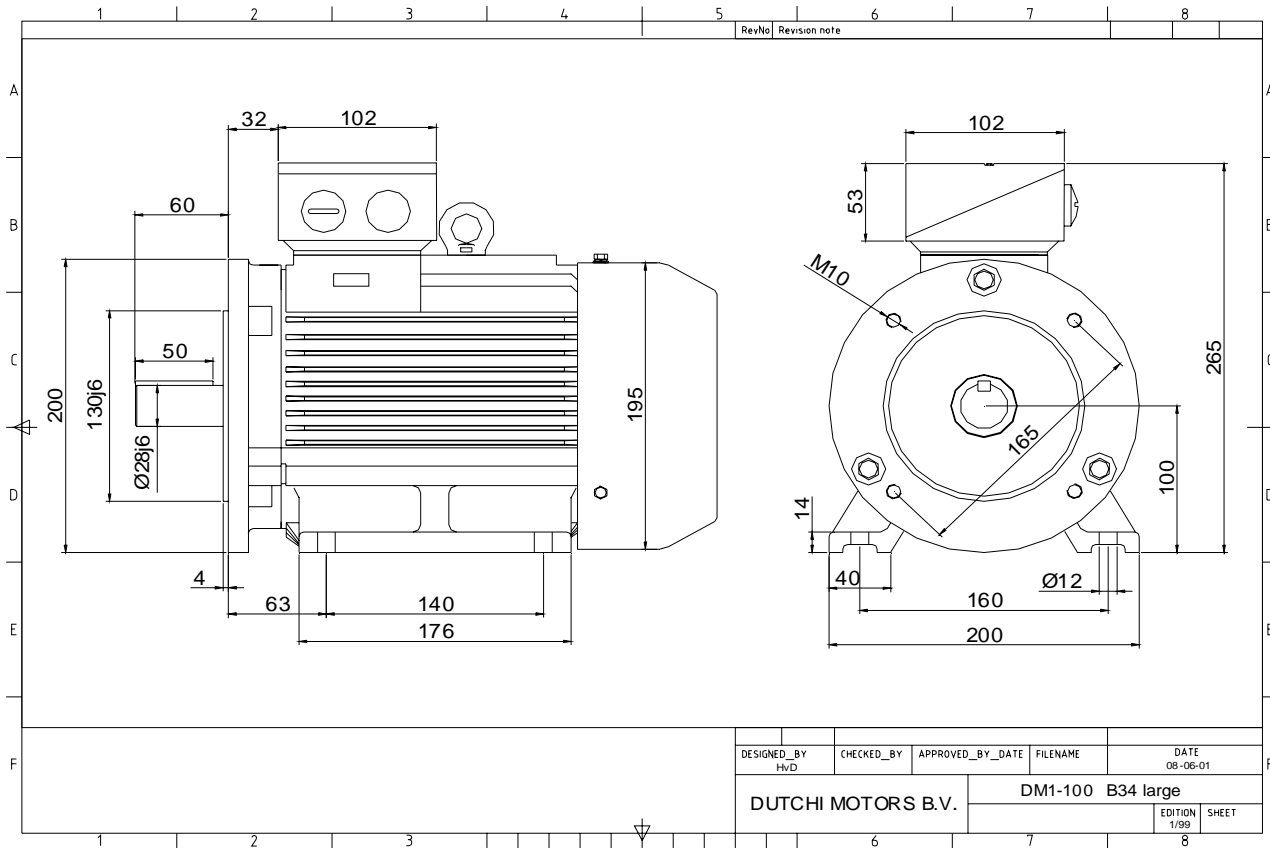

DESIGNED_BY HVD	CHECKED_BY	APPROVED_BY_DATE	FILENAME	DATE 08-06-01
DUTCHI MOTORS B.V.			DM1-100 B34 large	
			EDITION 1/99	SHEET

Specification	IEC 60034-1
Manufacturer	Dutchi Motors B.V.
Motor type	DM1- 100 L8
Rated power	0,75 kW S1 duty
Speed	705 r.p.m
Voltage	230 / 400 V
Frequency	50 Hz
Connection	Δ / Y
Amps full load	4,19 / 2,42 A
Amps no-load(400V)	2,02 A
Enclosure	IP 55
Insulation Class	F (temp. rise B (80 K))
Max. coolant temp.	40°C
Max. altitude	1.000 mtr, above sea level
Comment	3 x PTC 150°C
Cable entries	2 x M25x1,5 + 1 x M20x1,5 (ptc)
Feature	Cast-iron motor
Weight	33,0 kg
Catalog no.	11728075D
Warranty	12~18 months

Efficiency class	N/A			
Load data	100%	75%	50%	25%
Efficiency	68,8	66,6	60,1	44,1 %
Power factor	0,65	0,55	0,43	0,30
Sound pressure level (1m)				47,2 dB(A)
Resistance R20 (open)				8,87 Ω
Resistance R20	Y		17,75 Ω	
Full load torque				10,16 Nm
DOL Starting torque vs FL torque				2,29
DOL Pull up torque vs FL torque				1,59
DOL Pull out torque vs FL torque				2,85
Star-Delta Starting torque vs FL torque				Y - motor
Star-Delta Pull up torque vs FL torque				Y - motor
Star-Delta Pull out torque vs FL torque				Y - motor
DOL Starting current vs FL current				3,87
Star Delta Starting current vs FL current				Y - motor
Rotor Inertia				0,0063 kgm ²
Bearing DE				6206 - ZZ C3
Bearing NDE				6206 - ZZ C3

WI	Change	date	sign.
Dutchi Motors B.V. P.O. Box 5390 NL-6802 EJ ARNHEM Tel : +31-(0)26 - 3541 600 Fax : +31-(0)26 - 3541 650		Discription Drawing made by :	date 19-04-04 sign. HVD
		dutchi.motors@dutchi.nl www.dutchi.com	

Power is our commodity, the world is our market !

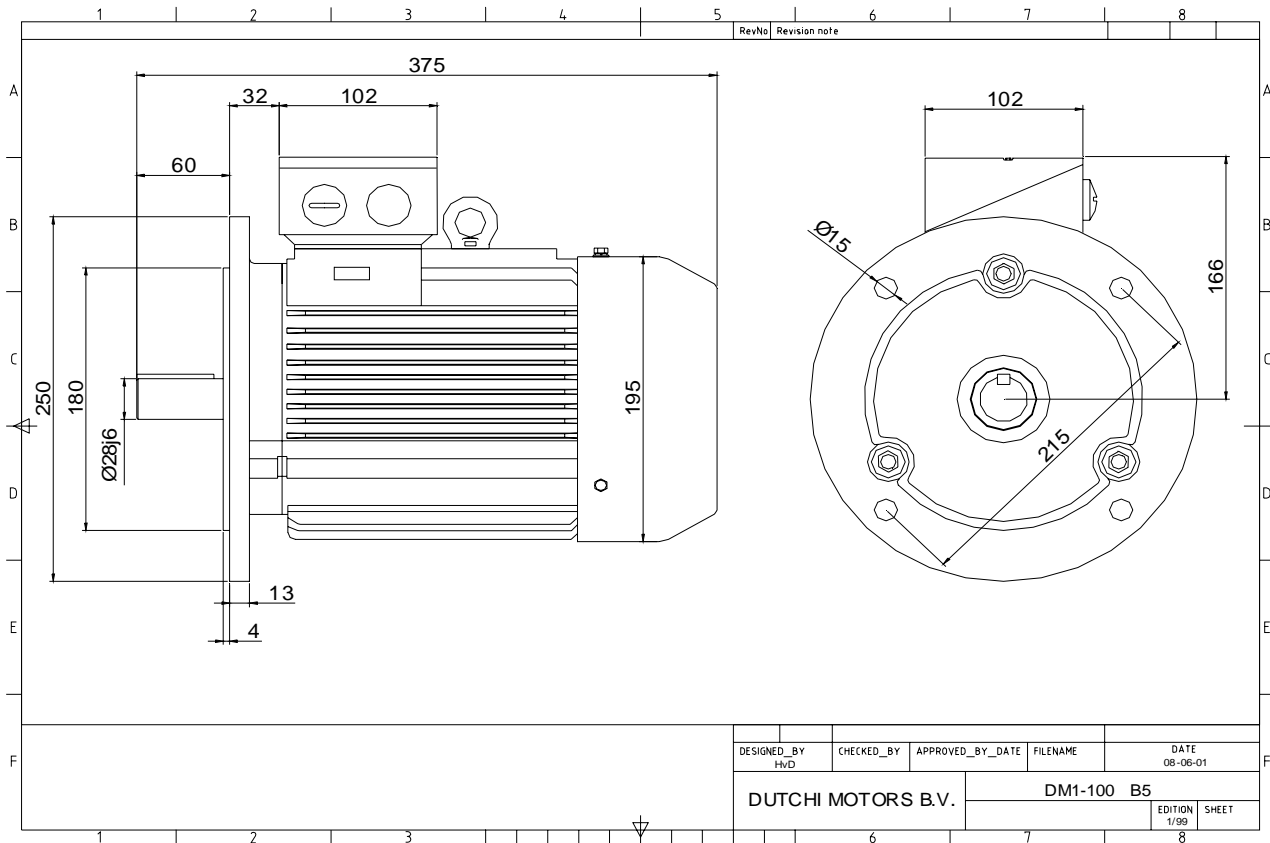

Specification **IEC 60034-1**
 Manufacturer **Dutchi Motors B.V.**
 Motor type **DM1- 100 L8**
 Rated power **0,75** kW **S1** duty
 Speed **705** r.p.m
 Voltage **230 / 400** V
 Frequency **50** Hz
 Connection **Δ / Y**
 Amps full load **4,19 / 2,42** A
 Amps no-load(400V) **2,02** A
 Enclosure **IP 55**
 Insulation Class **F (temp. rise B (80 K))**

Max. coolant temp. **40°C**
 Max. altitude **1.000** mtr, above sea level
 Comment **3 x PTC 150°C**
 Cable entries **2 x M25x1,5 + 1 x M20x1,5 (ptc)**

Feature **Cast-iron motor**
 Weight **33,0** kg
 Catalog no. **11228075D**
 Warranty **12~18 months**

Efficiency class **N/A**
 Load data 100% 75% 50% 25%
 Efficiency **68,8 66,6 60,1 44,1** %
 Power factor **0,65 0,55 0,43 0,30**

Sound pressure level (1m) **47,2** dB(A)
 Resistance R20 (open) **8,87** Ω
 Resistance R20 **Y 17,75** Ω

Full load torque **10,16** Nm
 DOL Starting torque vs FL torque **2,29**
 DOL Pull up torque vs FL torque **1,59**
 DOL Pull out torque vs FL torque **2,85**
 Star-Delta Starting torque vs FL torque **Y - motor**
 Star-Delta Pull up torque vs FL torque **Y - motor**
 Star-Delta Pull out torque vs FL torque **Y - motor**
 DOL Starting current vs FL current **3,87**
 Star Delta Starting current vs FL current **Y - motor**
 Rotor Inertia **0,0063** kgm²

Bearing DE **6206 - ZZ C3**
 Bearing NDE **6206 - ZZ C3**

WI	Change	date	sign.
Dutchi Motors B.V. P.O. Box 5390 NL-6802 EJ ARNHEM Tel : +31-(0)26 - 3541 600 Fax : +31-(0)26 - 3541 650		Discription Drawing made by :	date 19-04-04 sign. HvD
dutchi.motors@dutchi.nl www.dutchi.com			

Power is our commodity, the world is our market !

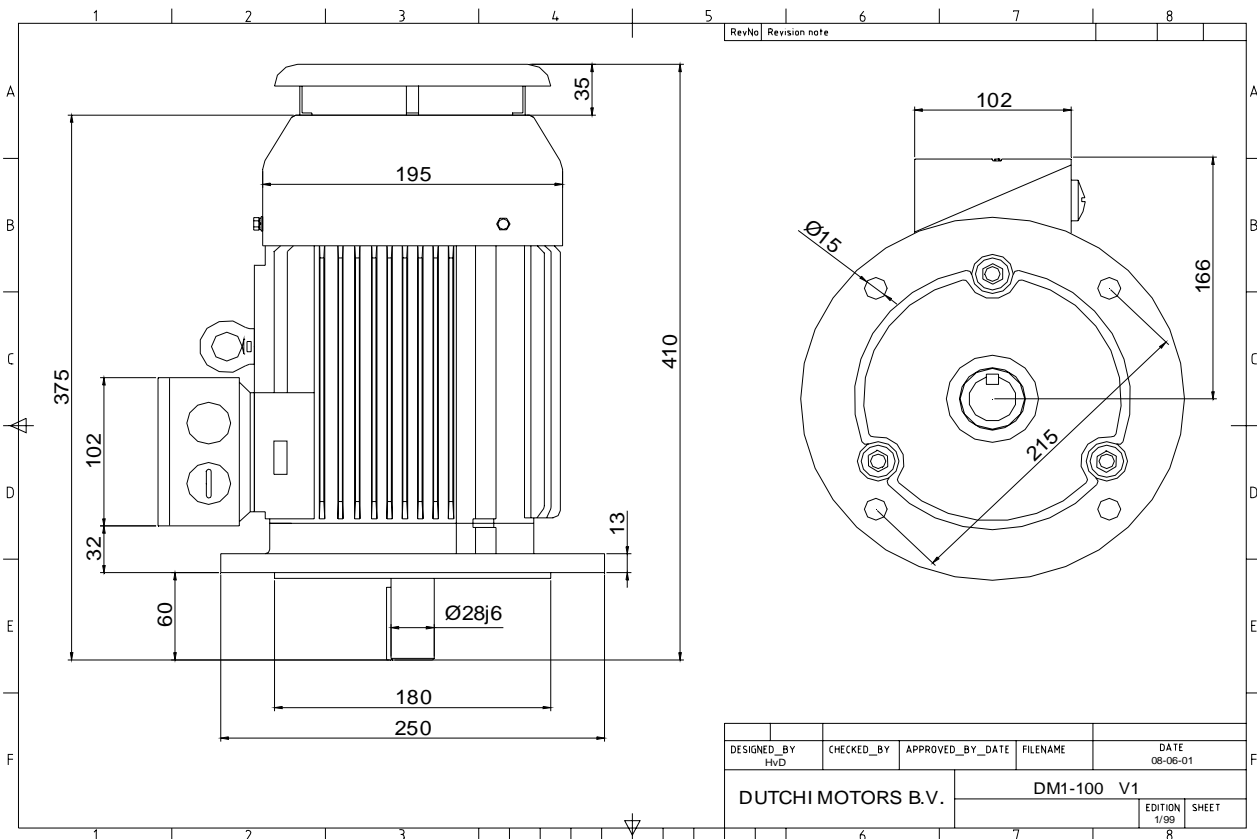

Specification **IEC 60034-1**
 Manufacturer **Dutchi Motors B.V.**
 Motor type **DM1- 100 L8**
 Rated power **0,75** kW **S1** duty
 Speed **705** r.p.m
 Voltage **230** / **400** V
 Frequency **50** Hz
 Connection **Δ** / **Y**
 Amps full load **4,19** / **2,42** A
 Amps no-load(400V) **2,02** A
 Enclosure **IP 55**
 Insulation Class **F (temp. rise B (80 K))**

Max. coolant temp. **40°C**
 Max. altitude **1.000** mtr, above sea level
 Comment **3 x PTC 150°C**
 Cable entries **2 x M25x1,5 + 1 x M20x1,5 (ptc)**

Feature **Cast-iron motor**
 Weight **33,0** kg
 Catalog no. **11028075D**
 Warranty **12~18 months**

Efficiency class **N/A**
 Load data 100% 75% 50% 25%
 Efficiency **68,8 66,6 60,1 44,1** %
 Power factor **0,65 0,55 0,43 0,30**

Sound pressure level (1m) **47,2** dB(A)
 Resistance R20 (open) **8,87** Ω
 Resistance R20 **Y 17,75** Ω

Full load torque **10,16** Nm
 DOL Starting torque vs FL torque **2,29**
 DOL Pull up torque vs FL torque **1,59**
 DOL Pull out torque vs FL torque **2,85**
 Star-Delta Starting torque vs FL torque **Y - motor**
 Star-Delta Pull up torque vs FL torque **Y - motor**
 Star-Delta Pull out torque vs FL torque **Y - motor**
 DOL Starting current vs FL current **3,87**
 Star Delta Starting current vs FL current **Y - motor**
 Rotor Inertia **0,0063** kgm²

Bearing DE **6206 - ZZ C3**
 Bearing NDE **6206 - ZZ C3**

WI	Change	date	sign.
Dutchi Motors B.V.		Description	date
P.O. Box 5390		Drawing made by :	19-04-04
NL-6802 EJ ARNHEM			
Tel : +31-(0)26 - 3541 600		dutchi.motors@dutchi.nl	
Fax : +31-(0)26 - 3541 650		www.dutchi.com	

Power is our commodity, the world is our market !

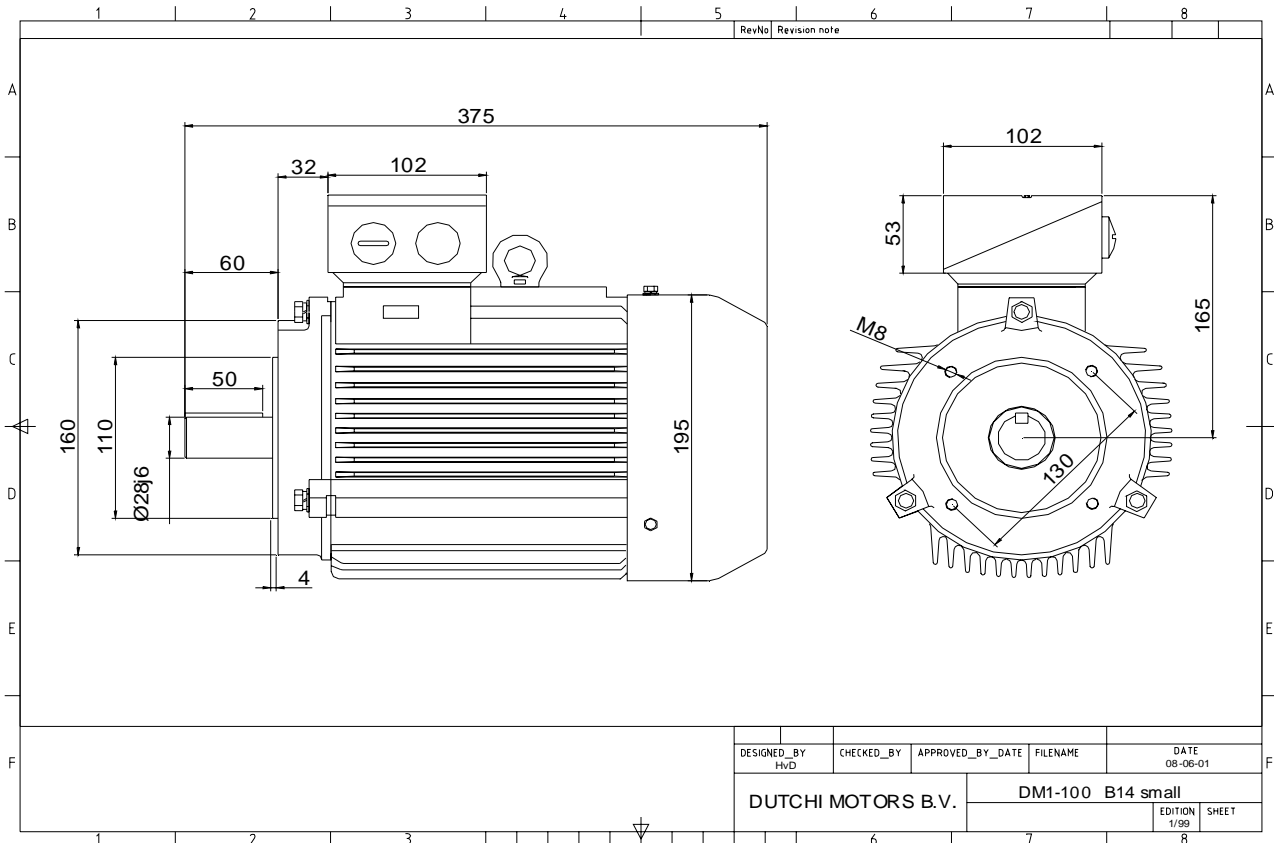

Specification **IEC 60034-1**
 Manufacturer **Dutchi Motors B.V.**
 Motor type **DM1- 100 L8**
 Rated power **0,75** kW **S1** duty
 Speed **705** r.p.m
 Voltage **230 / 400** V
 Frequency **50** Hz
 Connection **Δ / Y**
 Amps full load **4,19 / 2,42** A
 Amps no-load(400V) **2,02** A
 Enclosure **IP 55**
 Insulation Class **F (temp. rise B (80 K))**

Max. coolant temp. **40°C**
 Max. altitude **1.000** mtr, above sea level
 Comment **3 x PTC 150°C**
 Cable entries **2 x M25x1,5 + 1 x M20x1,5 (ptc)**

Feature **Cast-iron motor**
 Weight **33,0** kg
 Catalog no. **11328075D**
 Warranty **12~18 months**

Efficiency class **N/A**
 Load data 100% 75% 50% 25%
 Efficiency **68,8 66,6 60,1 44,1** %
 Power factor **0,65 0,55 0,43 0,30**

Sound pressure level (1m) **47,2** dB(A)
 Resistance R20 (open) **8,87** Ω
 Resistance R20 **Y 17,75** Ω

Full load torque **10,16** Nm
 DOL Starting torque vs FL torque **2,29**
 DOL Pull up torque vs FL torque **1,59**
 DOL Pull out torque vs FL torque **2,85**
 Star-Delta Starting torque vs FL torque **Y - motor**
 Star-Delta Pull up torque vs FL torque **Y - motor**
 Star-Delta Pull out torque vs FL torque **Y - motor**
 DOL Starting current vs FL current **3,87**
 Star Delta Starting current vs FL current **Y - motor**
 Rotor Inertia **0,0063** kgm²

Bearing DE **6206 - ZZ C3**
 Bearing NDE **6206 - ZZ C3**

WI	Change	date	sign.
Dutchi Motors B.V. P.O. Box 5390 NL-6802 EJ ARNHEM Tel : +31-(0)26 - 3541 600 Fax : +31-(0)26 - 3541 650		Description	date
		Drawing made by :	19-04-04
		dutchi.motors@dutchi.nl www.dutchi.com	

Power is our commodity, the world is our market !

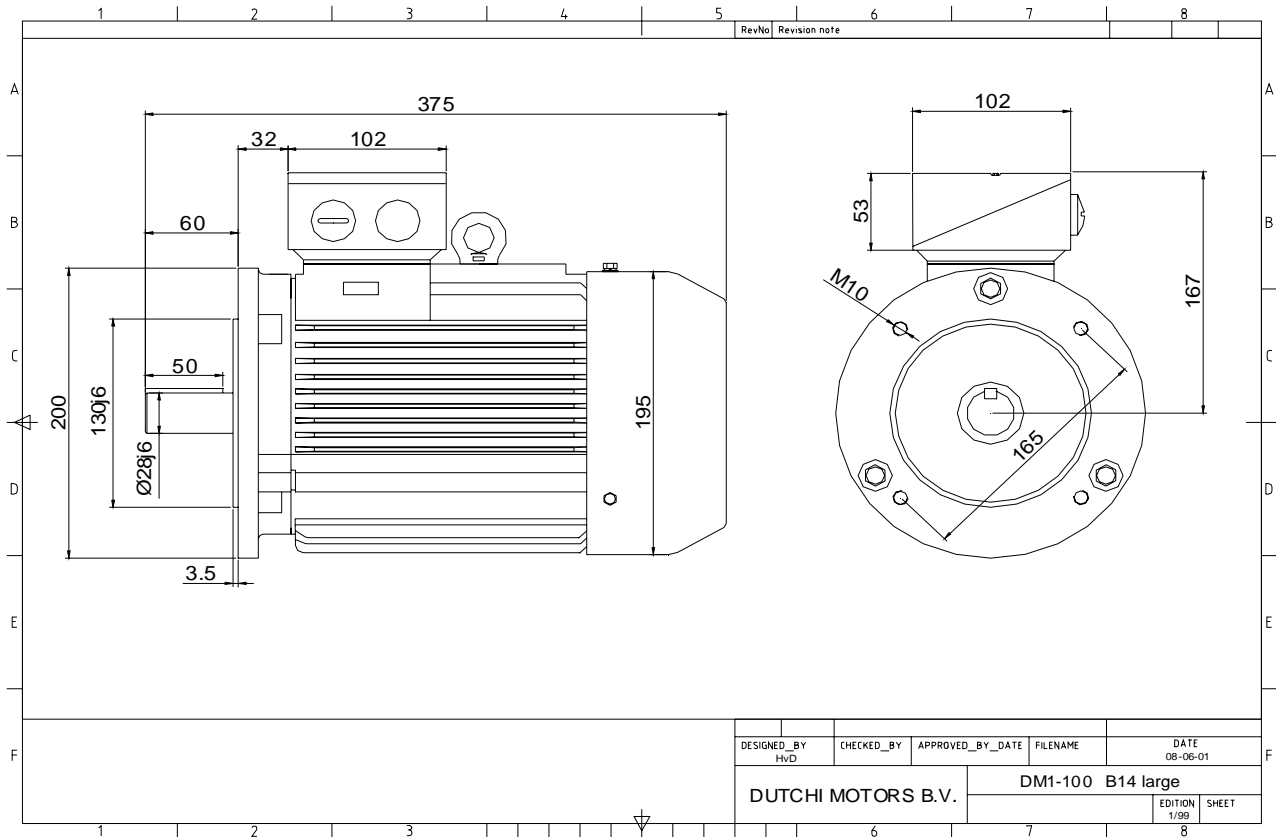

Specification **IEC 60034-1**
 Manufacturer **Dutchi Motors B.V.**
 Motor type **DM1- 100 L8**
 Rated power **0,75** kW **S1** duty
 Speed **705** r.p.m
 Voltage **230 / 400** V
 Frequency **50** Hz
 Connection **Δ / Y**
 Amps full load **4,19 / 2,42** A
 Amps no-load(400V) **2,02** A
 Enclosure **IP 55**
 Insulation Class **F (temp. rise B (80 K))**

Max. coolant temp. **40°C**
 Max. altitude **1.000** mtr, above sea level
 Comment **3 x PTC 150°C**
 Cable entries **2 x M25x1,5 + 1 x M20x1,5 (ptc)**

Feature **Cast-iron motor**
 Weight **33,0** kg
 Catalog no. **11428075D**
 Warranty **12~18 months**

Efficiency class **N/A**
 Load data 100% 75% 50% 25%
 Efficiency **68,8 66,6 60,1 44,1** %
 Power factor **0,65 0,55 0,43 0,30**

Sound pressure level (1m) **47,2** dB(A)
 Resistance R20 (open) **8,87** Ω
 Resistance R20 **Y 17,75** Ω

Full load torque **10,16** Nm
 DOL Starting torque vs FL torque **2,29**
 DOL Pull up torque vs FL torque **1,59**
 DOL Pull out torque vs FL torque **2,85**
 Star-Delta Starting torque vs FL torque **Y - motor**
 Star-Delta Pull up torque vs FL torque **Y - motor**
 Star-Delta Pull out torque vs FL torque **Y - motor**
 DOL Starting current vs FL current **3,87**
 Star Delta Starting current vs FL current **Y - motor**
 Rotor Inertia **0,0063** kgm²

Bearing DE **6206 - ZZ C3**
 Bearing NDE **6206 - ZZ C3**

WI	Change	date	sign.
Dutchi Motors B.V. P.O. Box 5390 NL-6802 EJ ARNHEM Tel : +31-(0)26 - 3541 600 Fax : +31-(0)26 - 3541 650		Discription Drawing made by :	date 19-04-04 sign. HVD
		dutchi.motors@dutchi.nl www.dutchi.com	