

Power is our commodity, the world is our market !

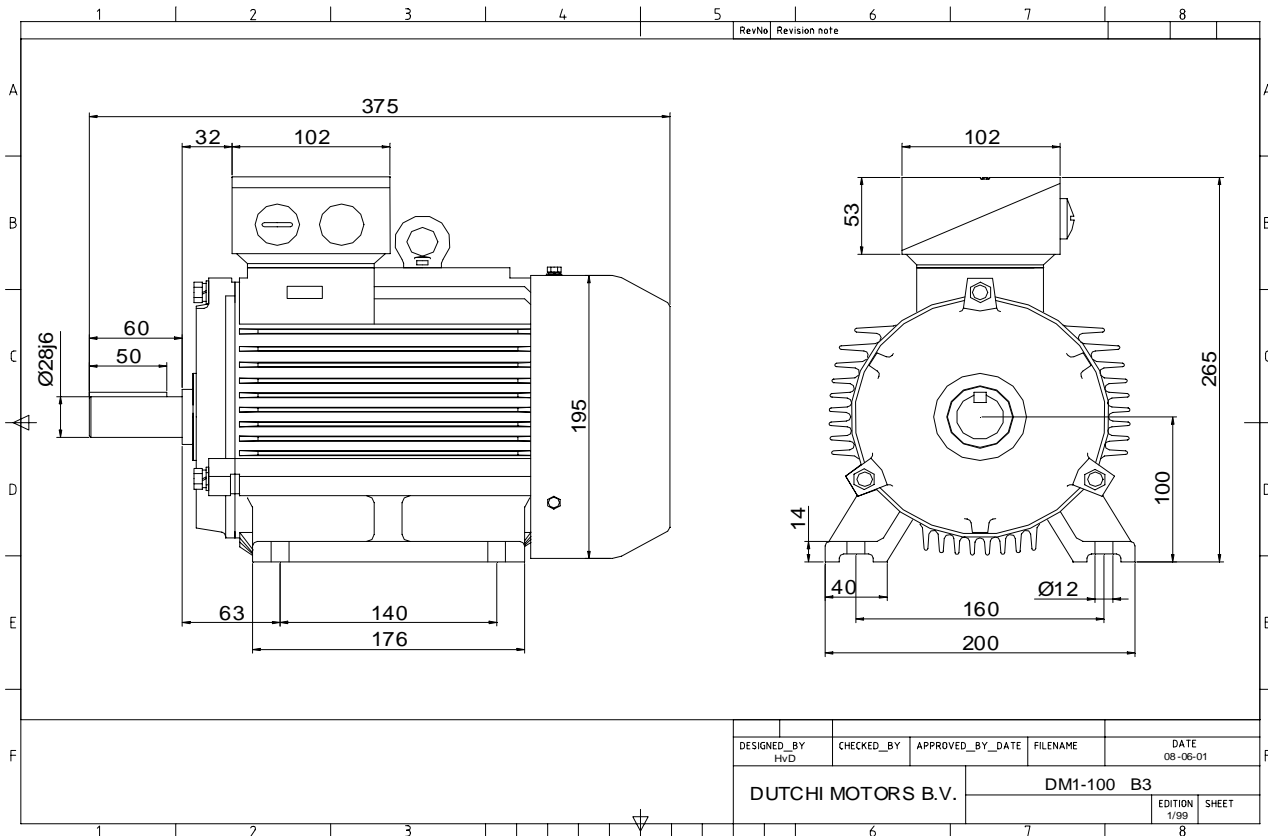

Specification **IEC 60034-1**  
 Manufacturer **Dutchi Motors B.V.**  
 Motor type **DM1- 100 LX8**  
 Rated power **1,1** kW **S1** duty  
 Speed **690** r.p.m  
 Voltage **230 / 400** V  
 Frequency **50** Hz  
 Connection **Δ / Y**  
 Amps full load **5,55 / 3,21** A  
 Amps no-load(400V) **2,50** A  
 Enclosure **IP 55**  
 Insulation Class **F (temp. rise B (80 K))**

Max. coolant temp. **40°C**  
 Max. altitude **1.000** mtr, above sea level  
 Comment **3 x PTC 150°C**  
 Cable entries **2 x M25x1,5 + 1 x M20x1,5 (ptc)**

Feature **Cast-iron motor**  
 Weight **34,0** kg  
 Catalog no. **11128110D**  
 Warranty **12~18 months**

Efficiency class **N/A**  
 Load data 100% 75% 50% 25%  
 Efficiency **71,2 70,7 65,4 50,4** %  
 Power factor **0,70 0,60 0,47 0,31**

Sound pressure level (1m) **49,3** dB(A)  
 Resistance R20 (open) **6,33** Ω  
 Resistance R20 **Y 12,66** Ω

Full load torque **15,22** Nm  
 DOL Starting torque vs FL torque **2,84**  
 DOL Pull up torque vs FL torque **1,65**  
 DOL Pull out torque vs FL torque **2,81**  
 Star-Delta Starting torque vs FL torque **Y - motor**  
 Star-Delta Pull up torque vs FL torque **Y - motor**  
 Star-Delta Pull out torque vs FL torque **Y - motor**  
 DOL Starting current vs FL current **4,03**  
 Star Delta Starting current vs FL current **Y - motor**  
 Rotor Inertia **0,0077** kgm<sup>2</sup>

Bearing DE **6206 - ZZ C3**  
 Bearing NDE **6206 - ZZ C3**

WI	Change	date	sign.
<b>Dutchi Motors B.V.</b> P.O. Box 5390 NL-6802 EJ ARNHEM Tel : +31-(0)26 - 3541 600 Fax : +31-(0)26 - 3541 650		Discription Drawing made by :	date 19-04-04 sign. HvD
dutchi.motors@dutchi.nl www.dutchi.com			

Power is our commodity, the world is our market !

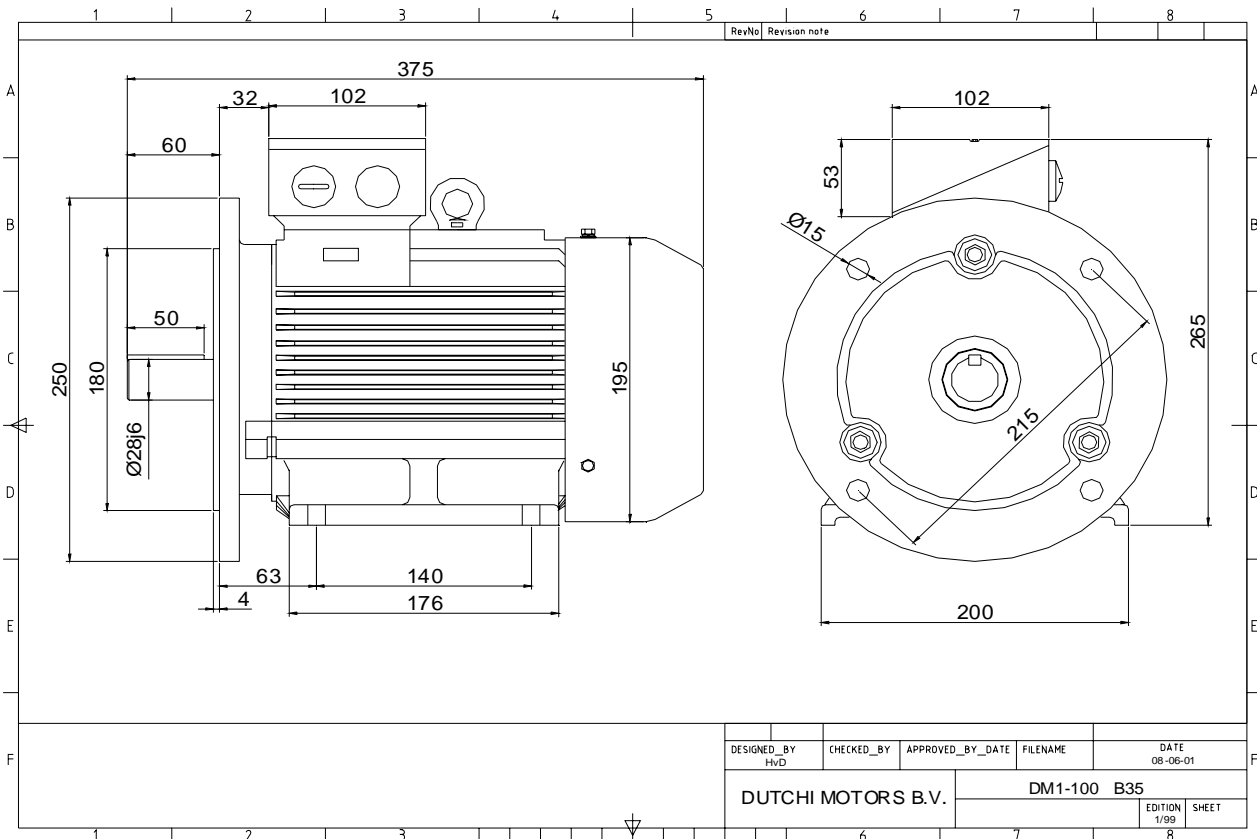

Specification	<b>IEC 60034-1</b>
Manufacturer	<b>Dutchi Motors B.V.</b>
Motor type	<b>DM1- 100 LX8</b>
Rated power	<b>1,1</b> kW <b>S1</b> duty
Speed	<b>690</b> r.p.m
Voltage	<b>230 / 400</b> V
Frequency	<b>50</b> Hz
Connection	<b>Δ / Y</b>
Amps full load	<b>5,55 / 3,21</b> A
Amps no-load(400V)	<b>2,50</b> A
Enclosure	<b>IP 55</b>
Insulation Class	<b>F (temp. rise B (80 K))</b>
Max. coolant temp.	<b>40°C</b>
Max. altitude	<b>1.000</b> mtr, above sea level
Comment	<b>3 x PTC 150°C</b>
Cable entries	<b>2 x M25x1,5 + 1 x M20x1,5 (ptc)</b>
Feature	<b>Cast-iron motor</b>
Weight	<b>34,0</b> kg
Catalog no.	<b>11528110D</b>
Warranty	<b>12~18 months</b>

Efficiency class	<b>N/A</b>			
Load data	100%	75%	50%	25%
Efficiency	<b>71,2</b>	<b>70,7</b>	<b>65,4</b>	<b>50,4</b> %
Power factor	<b>0,70</b>	<b>0,60</b>	<b>0,47</b>	<b>0,31</b>
Sound pressure level (1m)				<b>49,3</b> dB(A)
Resistance R20 (open)				<b>6,33</b> Ω
Resistance R20	<b>Y</b>		<b>12,66</b>	Ω
Full load torque				<b>15,22</b> Nm
DOL Starting torque vs FL torque				<b>2,84</b>
DOL Pull up torque vs FL torque				<b>1,65</b>
DOL Pull out torque vs FL torque				<b>2,81</b>
Star-Delta Starting torque vs FL torque				<b>Y - motor</b>
Star-Delta Pull up torque vs FL torque				<b>Y - motor</b>
Star-Delta Pull out torque vs FL torque				<b>Y - motor</b>
DOL Starting current vs FL current				<b>4,03</b>
Star Delta Starting current vs FL current				<b>Y - motor</b>
Rotor Inertia				<b>0,0077</b> kgm <sup>2</sup>
Bearing DE				<b>6206 - ZZ C3</b>
Bearing NDE				<b>6206 - ZZ C3</b>

WI	Change	date	sign.
<b>Dutchi Motors B.V.</b> P.O. Box 5390 NL-6802 EJ ARNHEM Tel : +31-(0)26 - 3541 600 Fax : +31-(0)26 - 3541 650		Discription Drawing made by :	date sign. HVD
dutchi.motors@dutchi.nl www.dutchi.com		19-04-04	

Power is our commodity, the world is our market !

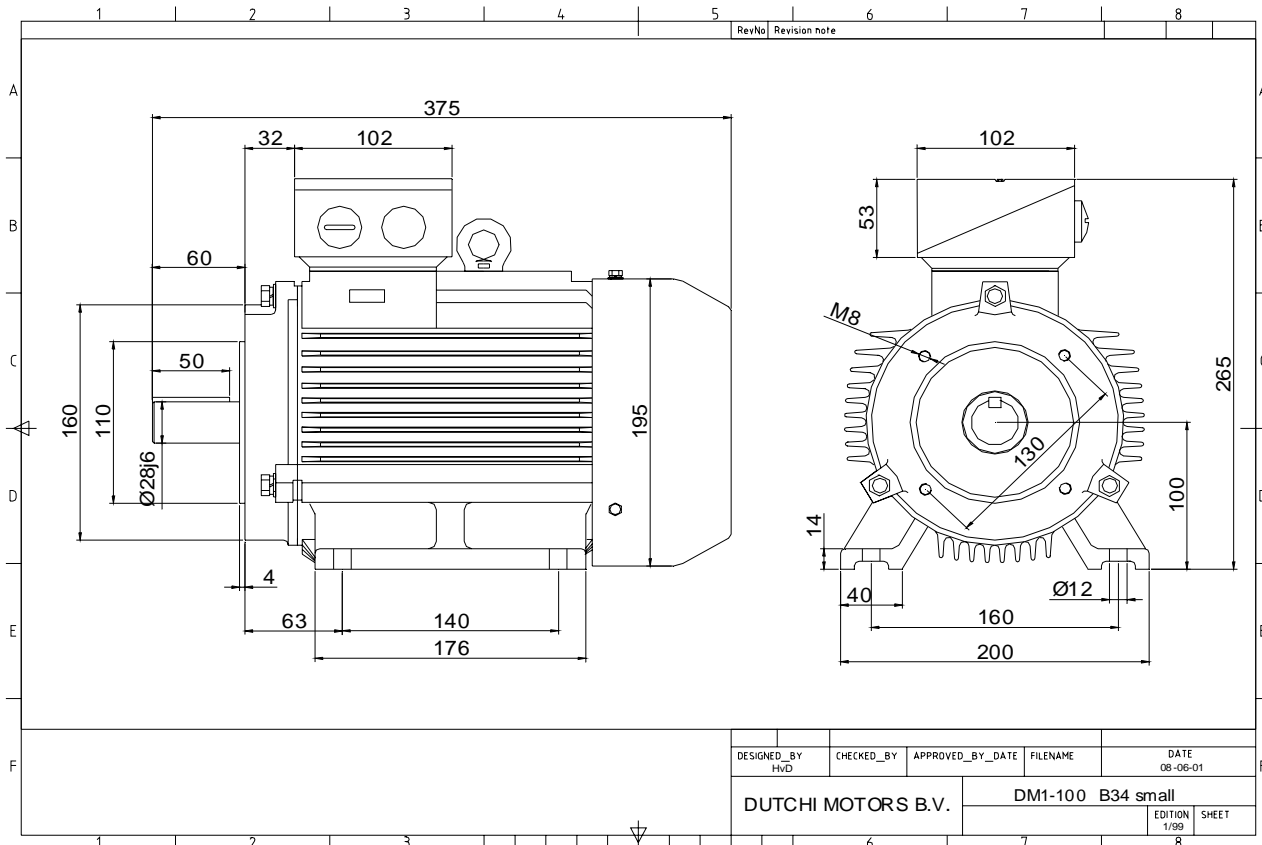

Specification **IEC 60034-1**  
 Manufacturer **Dutchi Motors B.V.**  
 Motor type **DM1- 100 LX8**  
 Rated power **1,1** kW **S1** duty  
 Speed **690** r.p.m  
 Voltage **230 / 400** V  
 Frequency **50** Hz  
 Connection **Δ / Y**  
 Amps full load **5,55 / 3,21** A  
 Amps no-load(400V) **2,50** A  
 Enclosure **IP 55**  
 Insulation Class **F (temp. rise B (80 K))**

Max. coolant temp. **40°C**  
 Max. altitude **1.000** mtr, above sea level  
 Comment **3 x PTC 150°C**  
 Cable entries **2 x M25x1,5 + 1 x M20x1,5 (ptc)**

Feature **Cast-iron motor**  
 Weight **34,0** kg  
 Catalog no. **11628110D**  
 Warranty **12~18 months**

Efficiency class **N/A**  
 Load data 100% 75% 50% 25%  
 Efficiency **71,2 70,7 65,4 50,4** %  
 Power factor **0,70 0,60 0,47 0,31**

Sound pressure level (1m) **49,3** dB(A)  
 Resistance R20 (open) **6,33** Ω  
 Resistance R20 **Y 12,66** Ω

Full load torque **15,22** Nm  
 DOL Starting torque vs FL torque **2,84**  
 DOL Pull up torque vs FL torque **1,65**  
 DOL Pull out torque vs FL torque **2,81**  
 Star-Delta Starting torque vs FL torque **Y - motor**  
 Star-Delta Pull up torque vs FL torque **Y - motor**  
 Star-Delta Pull out torque vs FL torque **Y - motor**  
 DOL Starting current vs FL current **4,03**  
 Star Delta Starting current vs FL current **Y - motor**  
 Rotor Inertia **0,0077** kgm<sup>2</sup>

Bearing DE **6206 - ZZ C3**  
 Bearing NDE **6206 - ZZ C3**

WI	Change	date	sign.
<b>Dutchi Motors B.V.</b> P.O. Box 5390 NL-6802 EJ ARNHEM Tel : +31-(0)26 - 3541 600 Fax : +31-(0)26 - 3541 650		Description	date
		Drawing made by :	19-04-04
		<b>dutchi.motors@dutchi.nl</b> <b>www.dutchi.com</b>	

Power is our commodity, the world is our market !

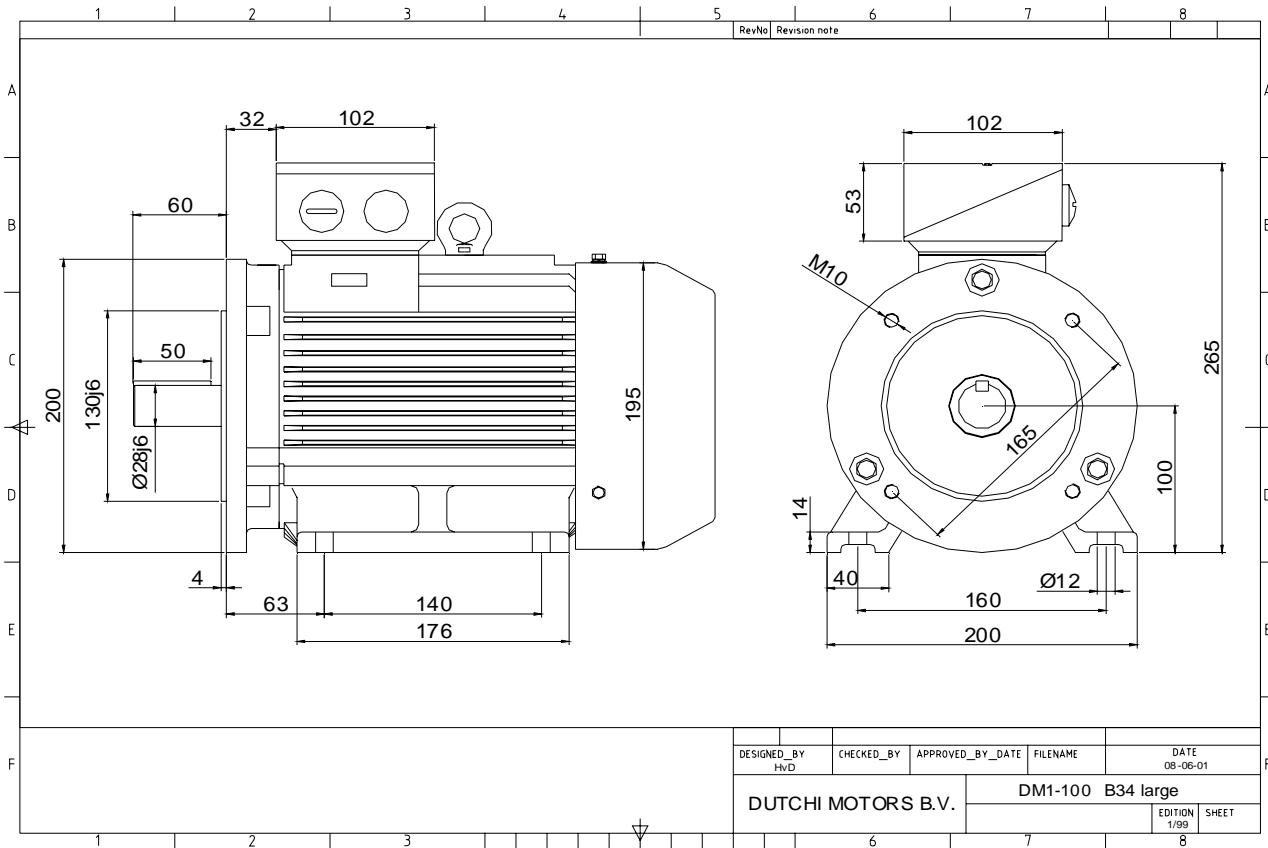

DESIGNED_BY HVD	CHECKED_BY	APPROVED_BY_DATE	FILENAME	DATE 08-06-01
DUTCHI MOTORS B.V.			DM1-100 B34 large	
EDITION 1/99		SHEET		

Specification	<b>IEC 60034-1</b>
Manufacturer	<b>Dutchi Motors B.V.</b>
Motor type	<b>DM1- 100 LX8</b>
Rated power	<b>1,1</b> kW <b>S1</b> duty
Speed	<b>690</b> r.p.m
Voltage	<b>230 / 400</b> V
Frequency	<b>50</b> Hz
Connection	<b>Δ / Y</b>
Amps full load	<b>5,55 / 3,21</b> A
Amps no-load(400V)	<b>2,50</b> A
Enclosure	<b>IP 55</b>
Insulation Class	<b>F (temp. rise B (80 K))</b>
Max. coolant temp.	<b>40°C</b>
Max. altitude	<b>1.000</b> mtr, above sea level
Comment	<b>3 x PTC 150°C</b>
Cable entries	<b>2 x M25x1,5 + 1 x M20x1,5 (ptc)</b>
Feature	<b>Cast-iron motor</b>
Weight	<b>34,0</b> kg
Catalog no.	<b>11728110D</b>
Warranty	<b>12~18 months</b>

Efficiency class	<b>N/A</b>			
Load data	<b>100%</b>	<b>75%</b>	<b>50%</b>	<b>25%</b>
Efficiency	<b>71,2</b>	<b>70,7</b>	<b>65,4</b>	<b>50,4</b> %
Power factor	<b>0,70</b>	<b>0,60</b>	<b>0,47</b>	<b>0,31</b>
Sound pressure level (1m)				<b>49,3</b> dB(A)
Resistance R20 (open)				<b>6,33</b> Ω
Resistance R20	<b>Y</b>		<b>12,66</b> Ω	
Full load torque				<b>15,22</b> Nm
DOL Starting torque vs FL torque				<b>2,84</b>
DOL Pull up torque vs FL torque				<b>1,65</b>
DOL Pull out torque vs FL torque				<b>2,81</b>
Star-Delta Starting torque vs FL torque				<b>Y - motor</b>
Star-Delta Pull up torque vs FL torque				<b>Y - motor</b>
Star-Delta Pull out torque vs FL torque				<b>Y - motor</b>
DOL Starting current vs FL current				<b>4,03</b>
Star Delta Starting current vs FL current				<b>Y - motor</b>
Rotor Inertia				<b>0,0077</b> kgm <sup>2</sup>
Bearing DE				<b>6206 - ZZ C3</b>
Bearing NDE				<b>6206 - ZZ C3</b>

WI	Change	date	sign.
Dutchi Motors B.V.		Description	date
P.O. Box 5390		Drawing made by :	19-04-04
NL-6802 EJ ARNHEM			
Tel : +31-(0)26 - 3541 600		dutchi.motors@dutchi.nl	
Fax : +31-(0)26 - 3541 650		www.dutchi.com	

Power is our commodity, the world is our market !

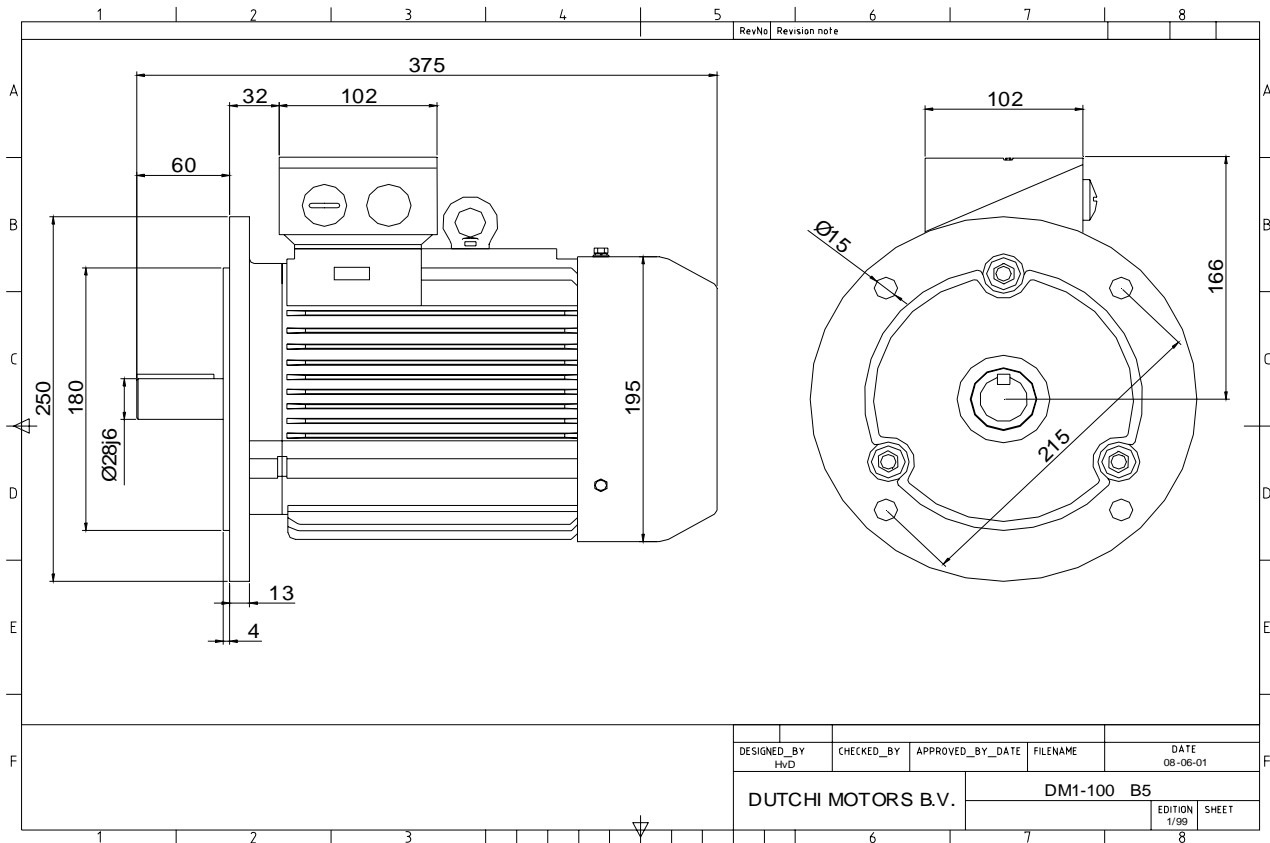

Specification	<b>IEC 60034-1</b>
Manufacturer	<b>Dutchi Motors B.V.</b>
Motor type	<b>DM1- 100 LX8</b>
Rated power	<b>1,1</b> kW <b>S1</b> duty
Speed	<b>690</b> r.p.m
Voltage	<b>230 / 400</b> V
Frequency	<b>50</b> Hz
Connection	<b>Δ / Y</b>
Amps full load	<b>5,55 / 3,21</b> A
Amps no-load(400V)	<b>2,50</b> A
Enclosure	<b>IP 55</b>
Insulation Class	<b>F (temp. rise B (80 K))</b>
Max. coolant temp.	<b>40°C</b>
Max. altitude	<b>1.000</b> mtr, above sea level
Comment	<b>3 x PTC 150°C</b>
Cable entries	<b>2 x M25x1,5 + 1 x M20x1,5 (ptc)</b>
Feature	<b>Cast-iron motor</b>
Weight	<b>34,0</b> kg
Catalog no.	<b>11228110D</b>
Warranty	<b>12~18 months</b>

Efficiency class	<b>N/A</b>			
Load data	100%	75%	50%	25%
Efficiency	<b>71,2</b>	<b>70,7</b>	<b>65,4</b>	<b>50,4</b> %
Power factor	<b>0,70</b>	<b>0,60</b>	<b>0,47</b>	<b>0,31</b>
Sound pressure level (1m)				<b>49,3</b> dB(A)
Resistance R20 (open)				<b>6,33</b> Ω
Resistance R20	<b>Y</b>		<b>12,66</b>	Ω
Full load torque				<b>15,22</b> Nm
DOL Starting torque vs FL torque				<b>2,84</b>
DOL Pull up torque vs FL torque				<b>1,65</b>
DOL Pull out torque vs FL torque				<b>2,81</b>
Star-Delta Starting torque vs FL torque				<b>Y - motor</b>
Star-Delta Pull up torque vs FL torque				<b>Y - motor</b>
Star-Delta Pull out torque vs FL torque				<b>Y - motor</b>
DOL Starting current vs FL current				<b>4,03</b>
Star Delta Starting current vs FL current				<b>Y - motor</b>
Rotor Inertia				<b>0,0077</b> kgm <sup>2</sup>
Bearing DE				<b>6206 - ZZ C3</b>
Bearing NDE				<b>6206 - ZZ C3</b>

WI	Change	date	sign.
<b>Dutchi Motors B.V.</b> P.O. Box 5390 NL-6802 EJ ARNHEM Tel : +31-(0)26 - 3541 600 Fax : +31-(0)26 - 3541 650		Discription Drawing made by :	date 19-04-04 sign. HvD
dutchi.motors@dutchi.nl www.dutchi.com			

Power is our commodity, the world is our market !

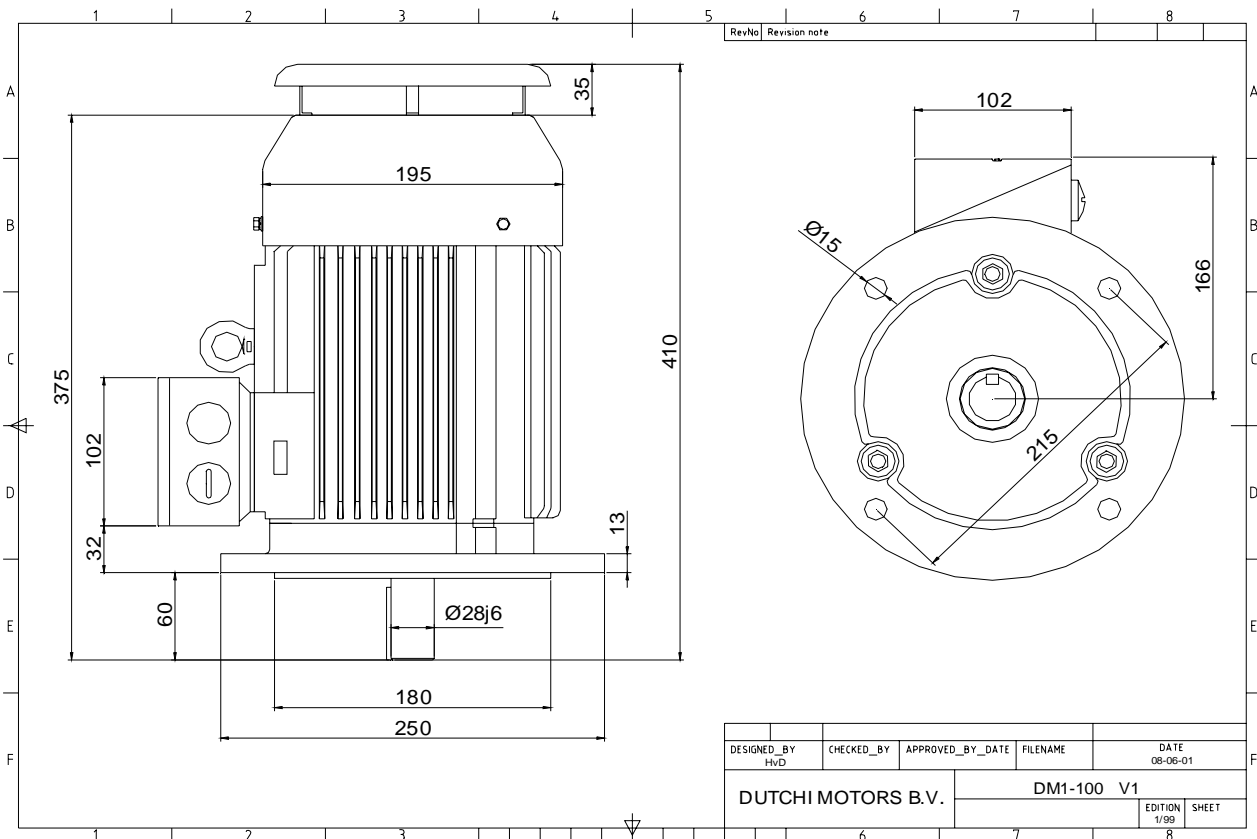

Specification **IEC 60034-1**  
 Manufacturer **Dutchi Motors B.V.**  
 Motor type **DM1- 100 LX8**  
 Rated power **1,1** kW **S1** duty  
 Speed **690** r.p.m  
 Voltage **230 / 400** V  
 Frequency **50** Hz  
 Connection **Δ / Y**  
 Amps full load **5,55 / 3,21** A  
 Amps no-load(400V) **2,50** A  
 Enclosure **IP 55**  
 Insulation Class **F (temp. rise B (80 K))**

Max. coolant temp. **40°C**  
 Max. altitude **1.000** mtr, above sea level  
 Comment **3 x PTC 150°C**  
 Cable entries **2 x M25x1,5 + 1 x M20x1,5 (ptc)**

Feature **Cast-iron motor**  
 Weight **34,0** kg  
 Catalog no. **11028110D**  
 Warranty **12~18 months**

Efficiency class **N/A**  
 Load data 100% 75% 50% 25%  
 Efficiency **71,2 70,7 65,4 50,4** %  
 Power factor **0,70 0,60 0,47 0,31**

Sound pressure level (1m) **49,3** dB(A)  
 Resistance R20 (open) **6,33** Ω  
 Resistance R20 **Y 12,66** Ω

Full load torque **15,22** Nm  
 DOL Starting torque vs FL torque **2,84**  
 DOL Pull up torque vs FL torque **1,65**  
 DOL Pull out torque vs FL torque **2,81**  
 Star-Delta Starting torque vs FL torque **Y - motor**  
 Star-Delta Pull up torque vs FL torque **Y - motor**  
 Star-Delta Pull out torque vs FL torque **Y - motor**  
 DOL Starting current vs FL current **4,03**  
 Star Delta Starting current vs FL current **Y - motor**  
 Rotor Inertia **0,0077** kgm<sup>2</sup>

Bearing DE **6206 - ZZ C3**  
 Bearing NDE **6206 - ZZ C3**

WI	Change	date	sign.
Dutchi Motors B.V.		Description	date
P.O. Box 5390		Drawing made by :	19-04-04
NL-6802 EJ ARNHEM			
Tel : +31-(0)26 - 3541 600		dutchi.motors@dutchi.nl	
Fax : +31-(0)26 - 3541 650		www.dutchi.com	

Power is our commodity, the world is our market !

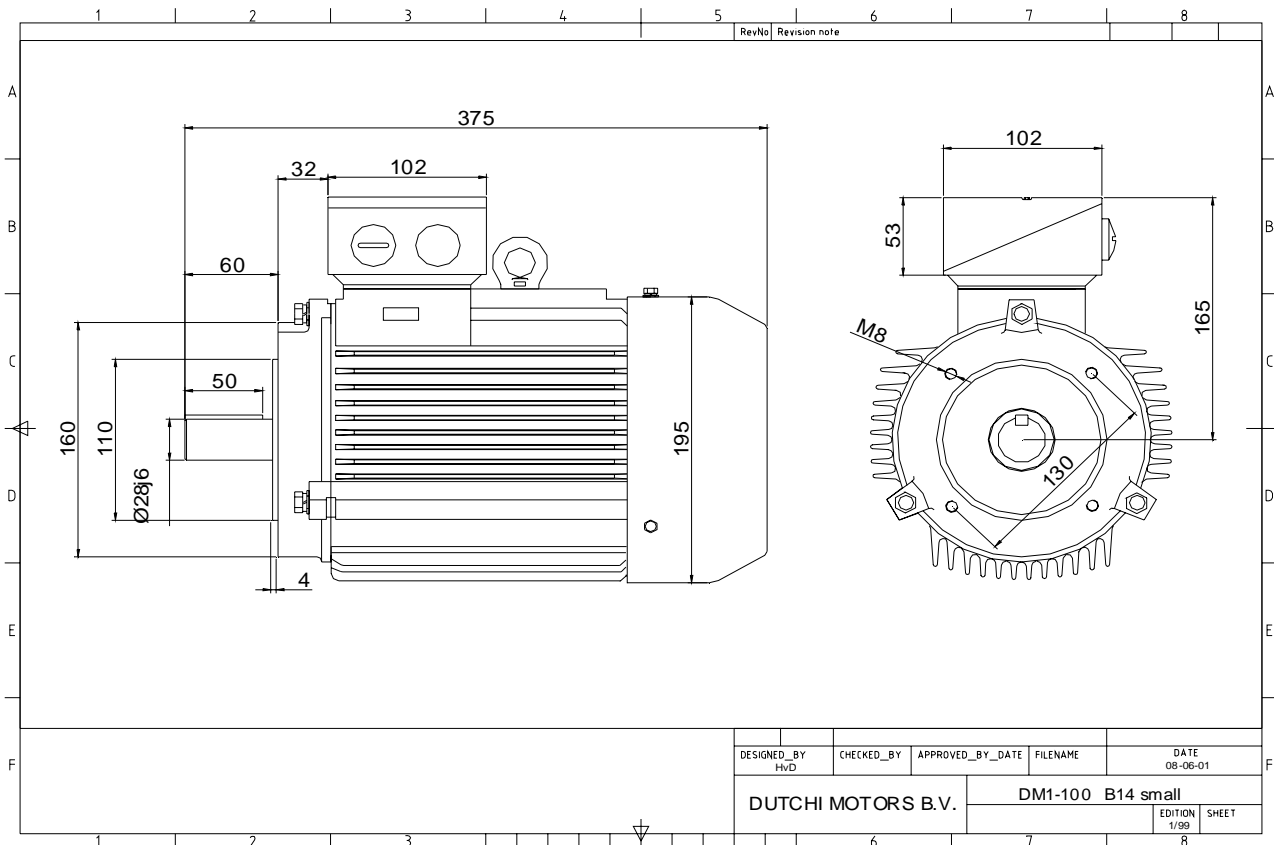

Specification **IEC 60034-1**  
 Manufacturer **Dutchi Motors B.V.**  
 Motor type **DM1- 100 LX8**  
 Rated power **1,1** kW **S1** duty  
 Speed **690** r.p.m  
 Voltage **230 / 400** V  
 Frequency **50** Hz  
 Connection **Δ / Y**  
 Amps full load **5,55 / 3,21** A  
 Amps no-load(400V) **2,50** A  
 Enclosure **IP 55**  
 Insulation Class **F (temp. rise B (80 K))**

Max. coolant temp. **40°C**  
 Max. altitude **1.000** mtr, above sea level  
 Comment **3 x PTC 150°C**  
 Cable entries **2 x M25x1,5 + 1 x M20x1,5 (ptc)**

Feature **Cast-iron motor**  
 Weight **34,0** kg  
 Catalog no. **11328110D**  
 Warranty **12~18 months**

Efficiency class **N/A**  
 Load data 100% 75% 50% 25%  
 Efficiency **71,2 70,7 65,4 50,4** %  
 Power factor **0,70 0,60 0,47 0,31**

Sound pressure level (1m) **49,3** dB(A)  
 Resistance R20 (open) **6,33** Ω  
 Resistance R20 **Y 12,66** Ω

Full load torque **15,22** Nm  
 DOL Starting torque vs FL torque **2,84**  
 DOL Pull up torque vs FL torque **1,65**  
 DOL Pull out torque vs FL torque **2,81**  
 Star-Delta Starting torque vs FL torque **Y - motor**  
 Star-Delta Pull up torque vs FL torque **Y - motor**  
 Star-Delta Pull out torque vs FL torque **Y - motor**  
 DOL Starting current vs FL current **4,03**  
 Star Delta Starting current vs FL current **Y - motor**  
 Rotor Inertia **0,0077** kgm2

Bearing DE **6206 - ZZ C3**  
 Bearing NDE **6206 - ZZ C3**

WI	Change	date	sign.
Dutchi Motors B.V.		Description	date
P.O. Box 5390		Drawing made by :	19-04-04
NL-6802 EJ ARNHEM			
Tel : +31-(0)26 - 3541 600		dutchi.motors@dutchi.nl	
Fax : +31-(0)26 - 3541 650		www.dutchi.com	

Power is our commodity, the world is our market !

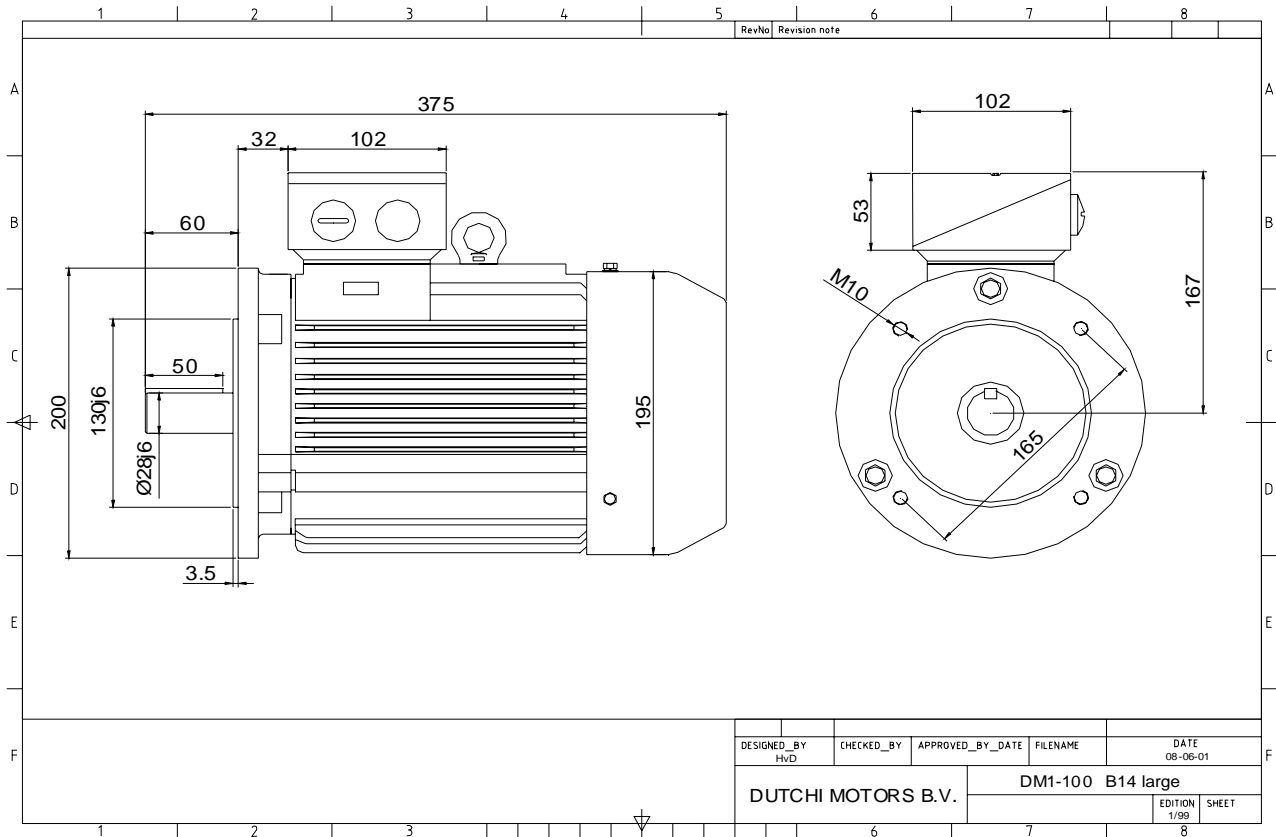

Specification **IEC 60034-1**  
 Manufacturer **Dutchi Motors B.V.**  
 Motor type **DM1- 100 LX8**  
 Rated power **1,1** kW **S1** duty  
 Speed **690** r.p.m  
 Voltage **230 / 400** V  
 Frequency **50** Hz  
 Connection **Δ / Y**  
 Amps full load **5,55 / 3,21** A  
 Amps no-load(400V) **2,50** A  
 Enclosure **IP 55**  
 Insulation Class **F (temp. rise B (80 K))**

Max. coolant temp. **40°C**  
 Max. altitude **1.000** mtr, above sea level  
 Comment **3 x PTC 150°C**  
 Cable entries **2 x M25x1,5 + 1 x M20x1,5 (ptc)**

Feature **Cast-iron motor**  
 Weight **34,0** kg  
 Catalog no. **11428110D**  
 Warranty **12~18 months**

Efficiency class **N/A**  
 Load data 100% 75% 50% 25%  
 Efficiency **71,2 70,7 65,4 50,4** %  
 Power factor **0,70 0,60 0,47 0,31**

Sound pressure level (1m) **49,3** dB(A)  
 Resistance R20 (open) **6,33** Ω  
 Resistance R20 **Y 12,66** Ω

Full load torque **15,22** Nm  
 DOL Starting torque vs FL torque **2,84**  
 DOL Pull up torque vs FL torque **1,65**  
 DOL Pull out torque vs FL torque **2,81**  
 Star-Delta Starting torque vs FL torque **Y - motor**  
 Star-Delta Pull up torque vs FL torque **Y - motor**  
 Star-Delta Pull out torque vs FL torque **Y - motor**  
 DOL Starting current vs FL current **4,03**  
 Star Delta Starting current vs FL current **Y - motor**  
 Rotor Inertia **0,0077** kgm2

Bearing DE **6206 - ZZ C3**  
 Bearing NDE **6206 - ZZ C3**

WI	Change	date	sign.
Dutchi Motors B.V.		Description	date
P.O. Box 5390		Drawing made by :	19-04-04
NL-6802 EJ ARNHEM			
Tel : +31-(0)26 - 3541 600		dutchi.motors@dutchi.nl	
Fax : +31-(0)26 - 3541 650		www.dutchi.com	