

Power is our commodity, the world is our market !

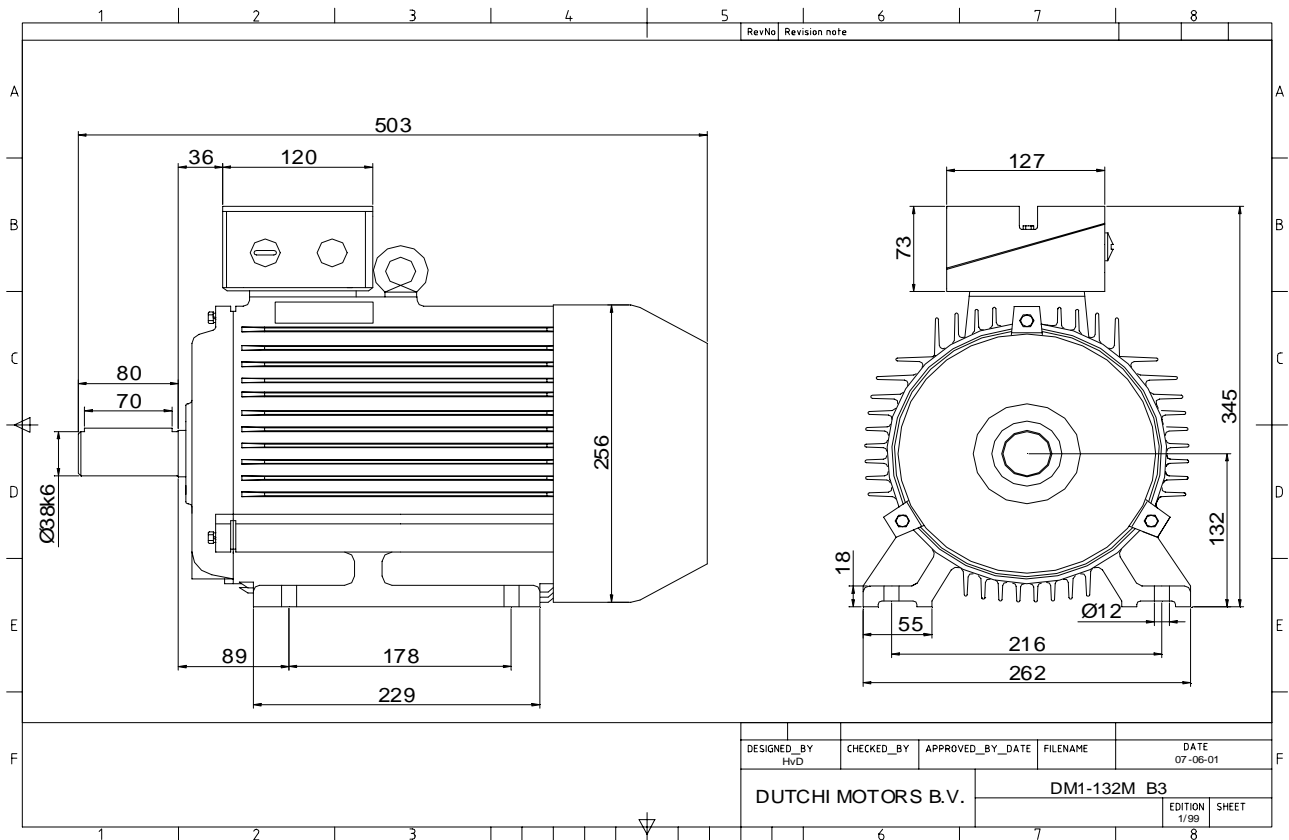

Specification **IEC 60034-1**  
 Manufacturer **Dutchi Motors B.V.**  
 Motor type **DM1- 132 M8**  
 Rated power **3** kW **S1** duty  
 Speed **710** r.p.m  
 Voltage **400 / 690** V  
 Frequency **50** Hz  
 Connection **Δ / Y**  
 Amps full load **7,31 / 4,22** A  
 Amps no-load(400V) **5,00** A  
 Enclosure **IP 55**  
 Insulation Class **F (temp. rise B (80 K))**

Max. coolant temp. **40°C**  
 Max. altitude **1.000** mtr, above sea level  
 Comment **3 x PTC 150°C**  
 Cable entries **2 x M32x1,5 + 1 x M20x1,5 (ptc)**

Feature **Cast-iron motor**  
 Weight **66,0** kg  
 Catalog no. **11138300D**  
 Warranty **12~18 months**

Efficiency class **N/A**  
 Load data 100% 75% 50% 25%  
 Efficiency **80,7 81,2 78,6 68,0** %  
 Power factor **0,73 0,64 0,50 0,31**

Sound pressure level (1m) **44,4** dB(A)  
 Resistance R20 (open) **6,36** Ω  
 Resistance R20 **Δ 4,24** Ω

Full load torque **40,35** Nm  
 DOL Starting torque vs FL torque **1,96**  
 DOL Pull up torque vs FL torque **1,69**  
 DOL Pull out torque vs FL torque **3,05**  
 Star-Delta Starting torque vs FL torque **0,61**  
 Star-Delta Pull up torque vs FL torque **0,53**  
 Star-Delta Pull out torque vs FL torque **0,95**  
 DOL Starting current vs FL current **5,21**  
 Star Delta Starting current vs FL current **1,63**  
 Rotor Inertia **0,0380** kgm<sup>2</sup>

Bearing DE **6308 - ZZ C3**  
 Bearing NDE **6308 - ZZ C3**

WI	Change	date	sign.
Dutchi Motors B.V.		Description	date
P.O. Box 5390		Drawing made by :	19-04-04
NL-6802 EJ ARNHEM			
Tel : +31-(0)26 - 3541 600		dutchi.motors@dutchi.nl	
Fax : +31-(0)26 - 3541 650		www.dutchi.com	

Power is our commodity, the world is our market !

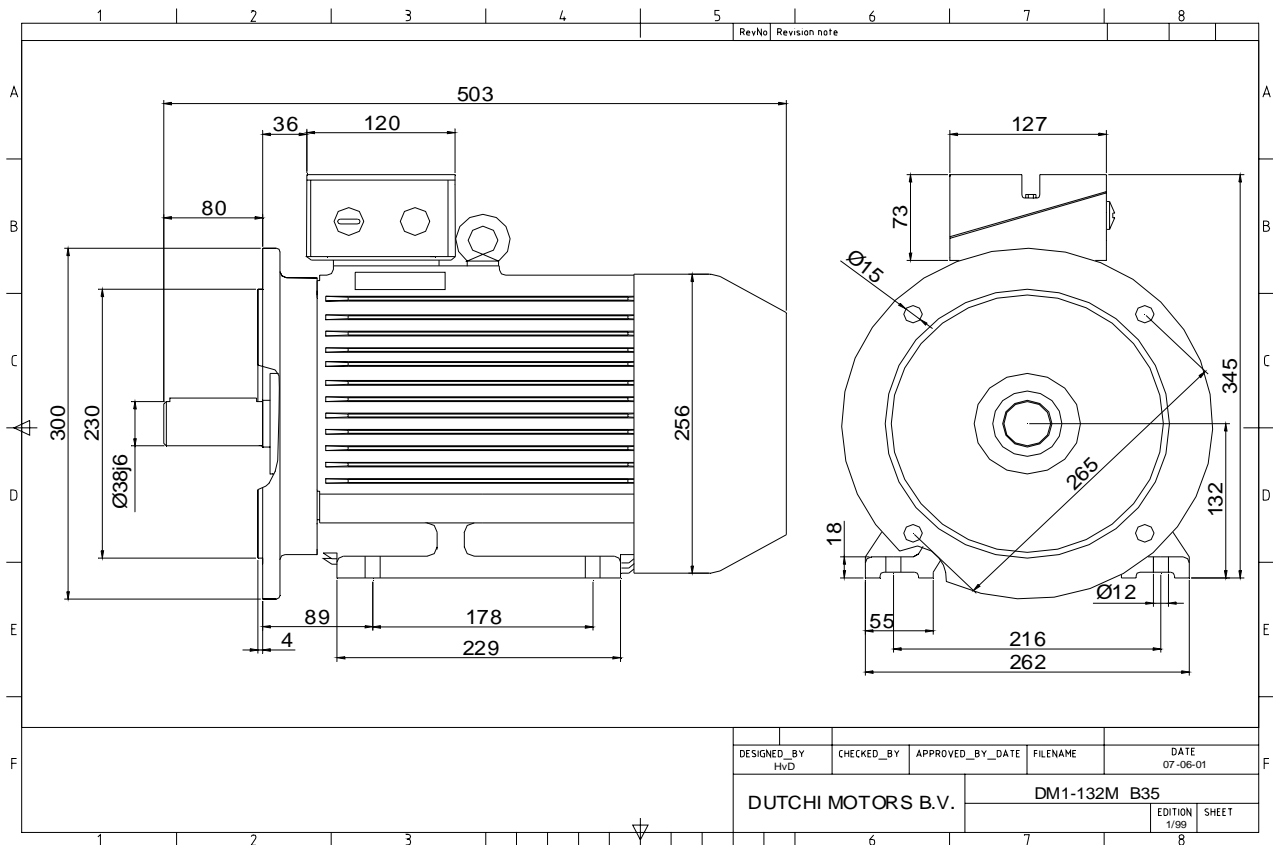

Specification **IEC 60034-1**  
 Manufacturer **Dutchi Motors B.V.**  
 Motor type **DM1- 132 M8**  
 Rated power **3** kW **S1** duty  
 Speed **710** r.p.m  
 Voltage **400 / 690** V  
 Frequency **50** Hz  
 Connection **Δ / Y**  
 Amps full load **7,31 / 4,22** A  
 Amps no-load(400V) **5,00** A  
 Enclosure **IP 55**  
 Insulation Class **F (temp. rise B (80 K))**

Max. coolant temp. **40°C**  
 Max. altitude **1.000** mtr, above sea level  
 Comment **3 x PTC 150°C**  
 Cable entries **2 x M32x1,5 + 1 x M20x1,5 (ptc)**

Feature **Cast-iron motor**  
 Weight **66,0** kg  
 Catalog no. **11538300D**  
 Warranty **12~18 months**

Efficiency class **N/A**  
 Load data 100% 75% 50% 25%  
 Efficiency **80,7 81,2 78,6 68,0** %  
 Power factor **0,73 0,64 0,50 0,31**

Sound pressure level (1m) **44,4** dB(A)  
 Resistance R20 (open) **6,36** Ω  
 Resistance R20 **Δ 4,24** Ω

Full load torque **40,35** Nm  
 DOL Starting torque vs FL torque **1,96**  
 DOL Pull up torque vs FL torque **1,69**  
 DOL Pull out torque vs FL torque **3,05**  
 Star-Delta Starting torque vs FL torque **0,61**  
 Star-Delta Pull up torque vs FL torque **0,53**  
 Star-Delta Pull out torque vs FL torque **0,95**  
 DOL Starting current vs FL current **5,21**  
 Star Delta Starting current vs FL current **1,63**  
 Rotor Inertia **0,0380** kgm<sup>2</sup>

Bearing DE **6308 - ZZ C3**  
 Bearing NDE **6308 - ZZ C3**

WI	Change	date	sign.
Dutchi Motors B.V.		Description	date
P.O. Box 5390		Drawing made by :	19-04-04
NL-6802 EJ ARNHEM			
Tel : +31-(0)26 - 3541 600		dutchi.motors@dutchi.nl	
Fax : +31-(0)26 - 3541 650		www.dutchi.com	

Power is our commodity, the world is our market !

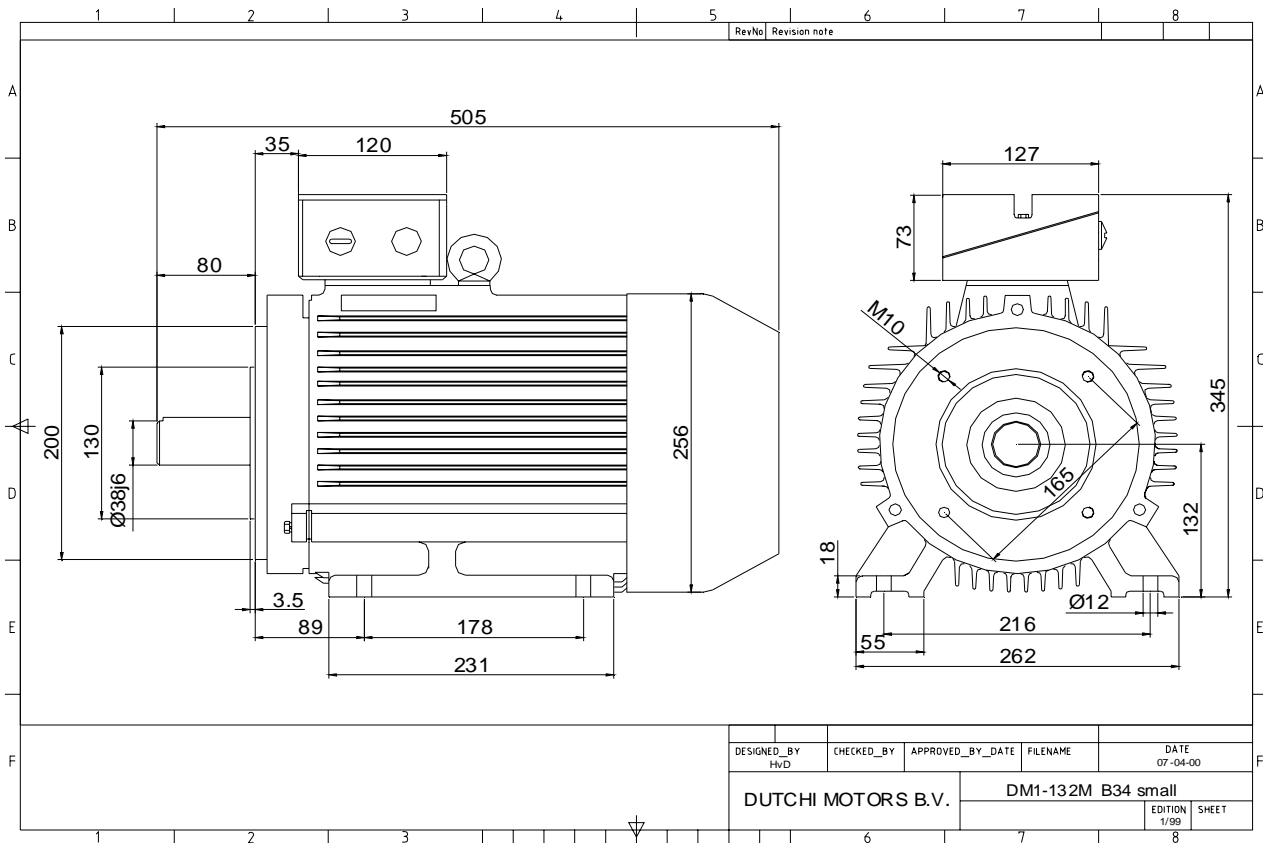

Specification **IEC 60034-1**  
 Manufacturer **Dutchi Motors B.V.**  
 Motor type **DM1- 132 M8**  
 Rated power **3** kW **S1** duty  
 Speed **710** r.p.m  
 Voltage **400 / 690** V  
 Frequency **50** Hz  
 Connection **Δ / Y**  
 Amps full load **7,31 / 4,22** A  
 Amps no-load(400V) **5,00** A  
 Enclosure **IP 55**  
 Insulation Class **F (temp. rise B (80 K))**

Max. coolant temp. **40°C**  
 Max. altitude **1.000** mtr, above sea level  
 Comment **3 x PTC 150°C**  
 Cable entries **2 x M32x1,5 + 1 x M20x1,5 (ptc)**

Feature **Cast-iron motor**  
 Weight **66,0** kg  
 Catalog no. **11638300D**  
 Warranty **12~18 months**

Efficiency class **N/A**  
 Load data 100% 75% 50% 25%  
 Efficiency **80,7 81,2 78,6 68,0** %  
 Power factor **0,73 0,64 0,50 0,31**

Sound pressure level (1m) **44,4** dB(A)  
 Resistance R20 (open) **6,36** Ω  
 Resistance R20 **Δ 4,24** Ω

Full load torque **40,35** Nm  
 DOL Starting torque vs FL torque **1,96**  
 DOL Pull up torque vs FL torque **1,69**  
 DOL Pull out torque vs FL torque **3,05**  
 Star-Delta Starting torque vs FL torque **0,61**  
 Star-Delta Pull up torque vs FL torque **0,53**  
 Star-Delta Pull out torque vs FL torque **0,95**  
 DOL Starting current vs FL current **5,21**  
 Star Delta Starting current vs FL current **1,63**  
 Rotor Inertia **0,0380** kgm2

Bearing DE **6308 - ZZ C3**  
 Bearing NDE **6308 - ZZ C3**

WI	Change	date	sign.
Dutchi Motors B.V.		Description	sign.
P.O. Box 5390		date	HvD
NL-6802 EJ ARNHEM		Drawing made by :	19-04-04
Tel : +31-(0)26 - 3541 600		dutchi.motors@dutchi.nl	
Fax : +31-(0)26 - 3541 650		www.dutchi.com	

Power is our commodity, the world is our market !

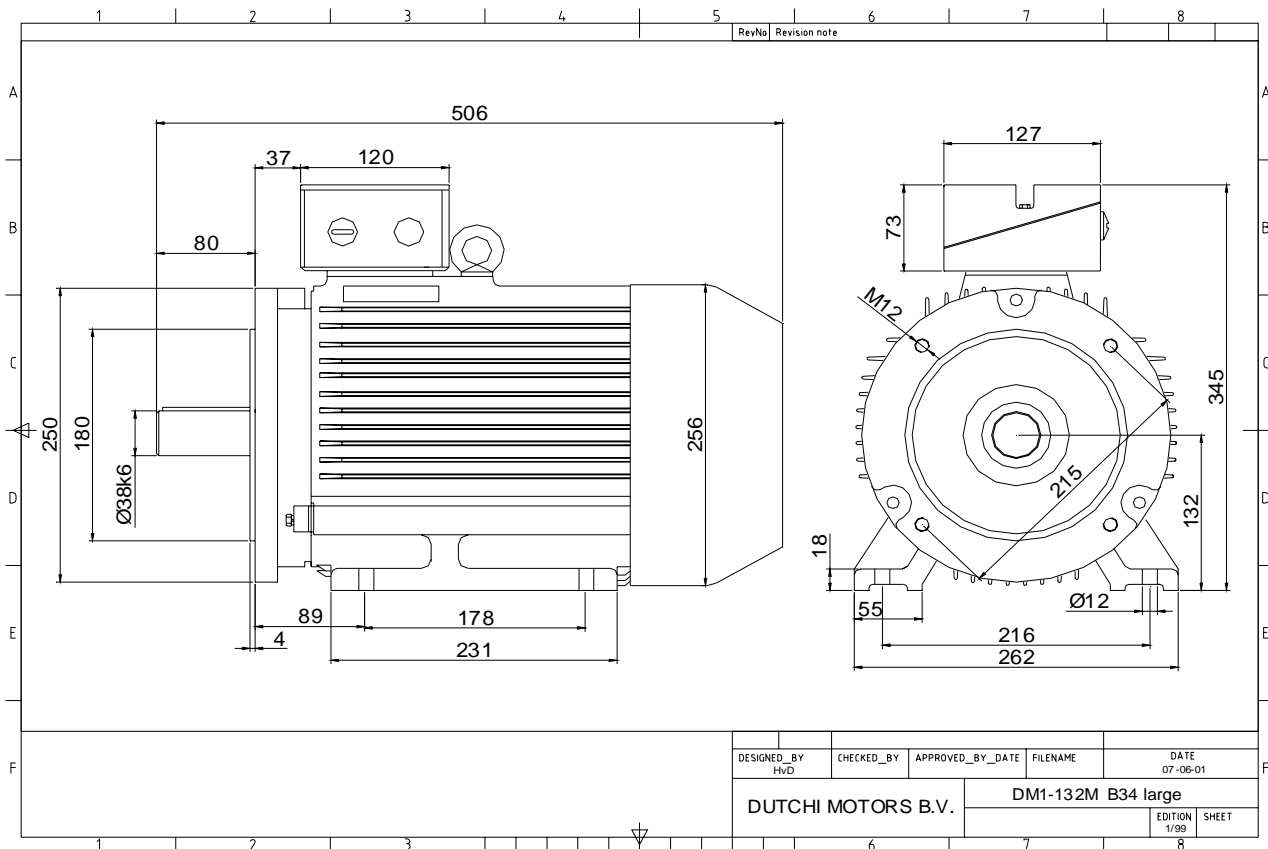

Specification **IEC 60034-1**  
 Manufacturer **Dutchi Motors B.V.**  
 Motor type **DM1- 132 M8**  
 Rated power **3** kW **S1** duty  
 Speed **710** r.p.m  
 Voltage **400 / 690** V  
 Frequency **50** Hz  
 Connection **Δ / Y**  
 Amps full load **7,31 / 4,22** A  
 Amps no-load(400V) **5,00** A  
 Enclosure **IP 55**  
 Insulation Class **F (temp. rise B (80 K))**

Max. coolant temp. **40°C**  
 Max. altitude **1.000** mtr, above sea level  
 Comment **3 x PTC 150°C**  
 Cable entries **2 x M32x1,5 + 1 x M20x1,5 (ptc)**

Feature **Cast-iron motor**  
 Weight **66,0** kg  
 Catalog no. **11738300D**  
 Warranty **12~18 months**

Efficiency class **N/A**  
 Load data 100% 75% 50% 25%  
 Efficiency **80,7 81,2 78,6 68,0** %  
 Power factor **0,73 0,64 0,50 0,31**

Sound pressure level (1m) **44,4** dB(A)  
 Resistance R20 (open) **6,36** Ω  
 Resistance R20 **Δ 4,24** Ω

Full load torque **40,35** Nm  
 DOL Starting torque vs FL torque **1,96**  
 DOL Pull up torque vs FL torque **1,69**  
 DOL Pull out torque vs FL torque **3,05**  
 Star-Delta Starting torque vs FL torque **0,61**  
 Star-Delta Pull up torque vs FL torque **0,53**  
 Star-Delta Pull out torque vs FL torque **0,95**  
 DOL Starting current vs FL current **5,21**  
 Star Delta Starting current vs FL current **1,63**  
 Rotor Inertia **0,0380** kgm<sup>2</sup>

Bearing DE **6308 - ZZ C3**  
 Bearing NDE **6308 - ZZ C3**

WI	Change	date	sign.
<b>Dutchi Motors B.V.</b> P.O. Box 5390 NL-6802 EJ ARNHEM Tel : +31-(0)26 - 3541 600 Fax : +31-(0)26 - 3541 650		Discription Drawing made by :	date sign. HVD
		<b>dutchi.motors@dutchi.nl</b> <b>www.dutchi.com</b>	

Power is our commodity, the world is our market !

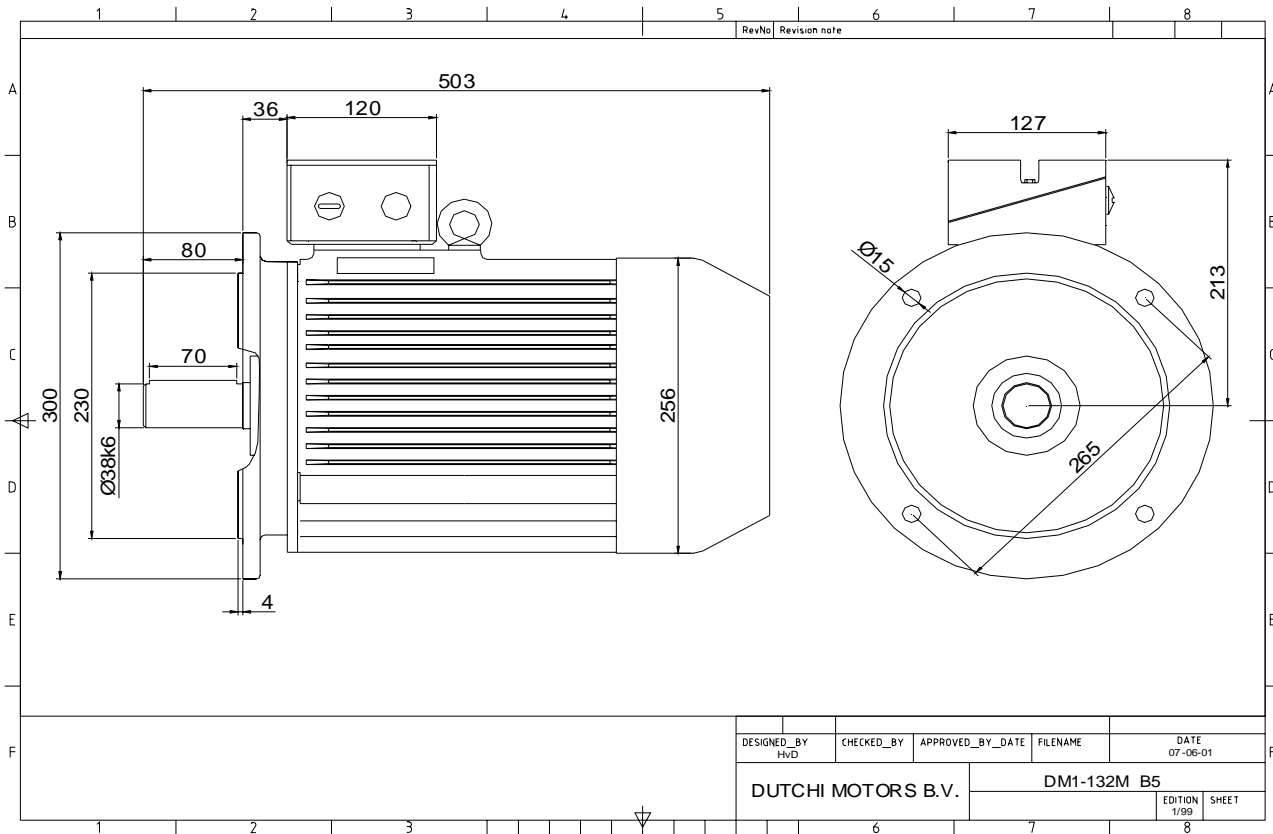

DESIGNED_BY HvD	CHECKED_BY	APPROVED_BY_DATE	FILENAME	DATE 07-06-01
DUTCHI MOTORS B.V.			DM1-132M B5	
			EDITION 1/99	SHEET

Specification	<b>IEC 60034-1</b>
Manufacturer	<b>Dutchi Motors B.V.</b>
Motor type	<b>DM1- 132 M8</b>
Rated power	<b>3</b> kW <b>S1</b> duty
Speed	<b>710</b> r.p.m
Voltage	<b>400 / 690</b> V
Frequency	<b>50</b> Hz
Connection	<b>Δ / Y</b>
Amps full load	<b>7,31 / 4,22</b> A
Amps no-load(400V)	<b>5,00</b> A
Enclosure	<b>IP 55</b>
Insulation Class	<b>F (temp. rise B (80 K))</b>
Max. coolant temp.	<b>40°C</b>
Max. altitude	<b>1.000</b> mtr, above sea level
Comment	<b>3 x PTC 150°C</b>
Cable entries	<b>2 x M32x1,5 + 1 x M20x1,5 (ptc)</b>
Feature	<b>Cast-iron motor</b>
Weight	<b>66,0</b> kg
Catalog no.	<b>11208300D</b>
Warranty	<b>12~18 months</b>

Efficiency class	<b>N/A</b>			
Load data	100%	75%	50%	25%
Efficiency	<b>80,7</b>	<b>81,2</b>	<b>78,6</b>	<b>68,0</b> %
Power factor	<b>0,73</b>	<b>0,64</b>	<b>0,50</b>	<b>0,31</b>
Sound pressure level (1m)				<b>44,4</b> dB(A)
Resistance R20 (open)				<b>6,36</b> Ω
Resistance R20	<b>Δ</b>			<b>4,24</b> Ω
Full load torque				<b>40,35</b> Nm
DOL Starting torque vs FL torque				<b>1,96</b>
DOL Pull up torque vs FL torque				<b>1,69</b>
DOL Pull out torque vs FL torque				<b>3,05</b>
Star-Delta Starting torque vs FL torque				<b>0,61</b>
Star-Delta Pull up torque vs FL torque				<b>0,53</b>
Star-Delta Pull out torque vs FL torque				<b>0,95</b>
DOL Starting current vs FL current				<b>5,21</b>
Star Delta Starting current vs FL current				<b>1,63</b>
Rotor Inertia				<b>0,0380</b> kgm <sup>2</sup>
Bearing DE				<b>6308 - ZZ C3</b>
Bearing NDE				<b>6308 - ZZ C3</b>

WI	Change	date	sign.
<b>Dutchi Motors B.V.</b> P.O. Box 5390 NL-6802 EJ ARNHEM Tel : +31-(0)26 - 3541 600 Fax : +31-(0)26 - 3541 650		Discription Drawing made by :	date 19-04-04
		sign.	HvD
		dutchi.motors@dutchi.nl www.dutchi.com	

Power is our commodity, the world is our market !

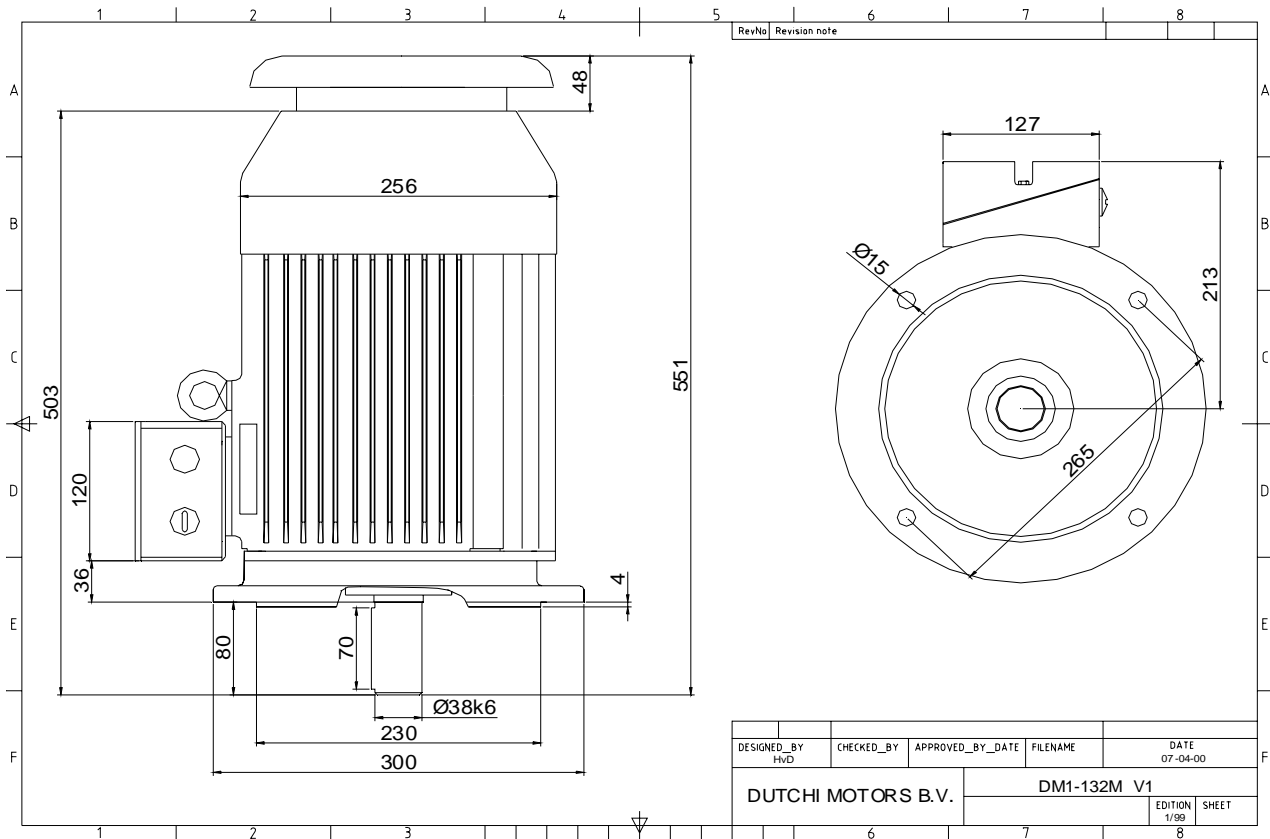

Specification **IEC 60034-1**  
 Manufacturer **Dutchi Motors B.V.**  
 Motor type **DM1- 132 M8**  
 Rated power **3** kW **S1** duty  
 Speed **710** r.p.m  
 Voltage **400 / 690** V  
 Frequency **50** Hz  
 Connection **Δ / Y**  
 Amps full load **7,31 / 4,22** A  
 Amps no-load(400V) **5,00** A  
 Enclosure **IP 55**  
 Insulation Class **F (temp. rise B (80 K))**

Max. coolant temp. **40°C**  
 Max. altitude **1.000** mtr, above sea level  
 Comment **3 x PTC 150°C**  
 Cable entries **2 x M32x1,5 + 1 x M20x1,5 (ptc)**

Feature **Cast-iron motor**  
 Weight **66,0** kg  
 Catalog no. **11038300D**  
 Warranty **12~18 months**

Efficiency class **N/A**  
 Load data 100% 75% 50% 25%  
 Efficiency **80,7 81,2 78,6 68,0** %  
 Power factor **0,73 0,64 0,50 0,31**

Sound pressure level (1m) **44,4** dB(A)  
 Resistance R20 (open) **6,36** Ω  
 Resistance R20 **Δ 4,24** Ω

Full load torque **40,35** Nm  
 DOL Starting torque vs FL torque **1,96**  
 DOL Pull up torque vs FL torque **1,69**  
 DOL Pull out torque vs FL torque **3,05**  
 Star-Delta Starting torque vs FL torque **0,61**  
 Star-Delta Pull up torque vs FL torque **0,53**  
 Star-Delta Pull out torque vs FL torque **0,95**  
 DOL Starting current vs FL current **5,21**  
 Star Delta Starting current vs FL current **1,63**  
 Rotor Inertia **0,0380** kgm2

Bearing DE **6308 - ZZ C3**  
 Bearing NDE **6308 - ZZ C3**

WI	Change	date	sign.
<b>Dutchi Motors B.V.</b> P.O. Box 5390 NL-6802 EJ ARNHEM Tel : +31-(0)26 - 3541 600 Fax : +31-(0)26 - 3541 650		Discription Drawing made by :	date 19-04-04 sign. HvD
		<b>dutchi.motors@dutchi.nl</b> <b>www.dutchi.com</b>	

Power is our commodity, the world is our market !

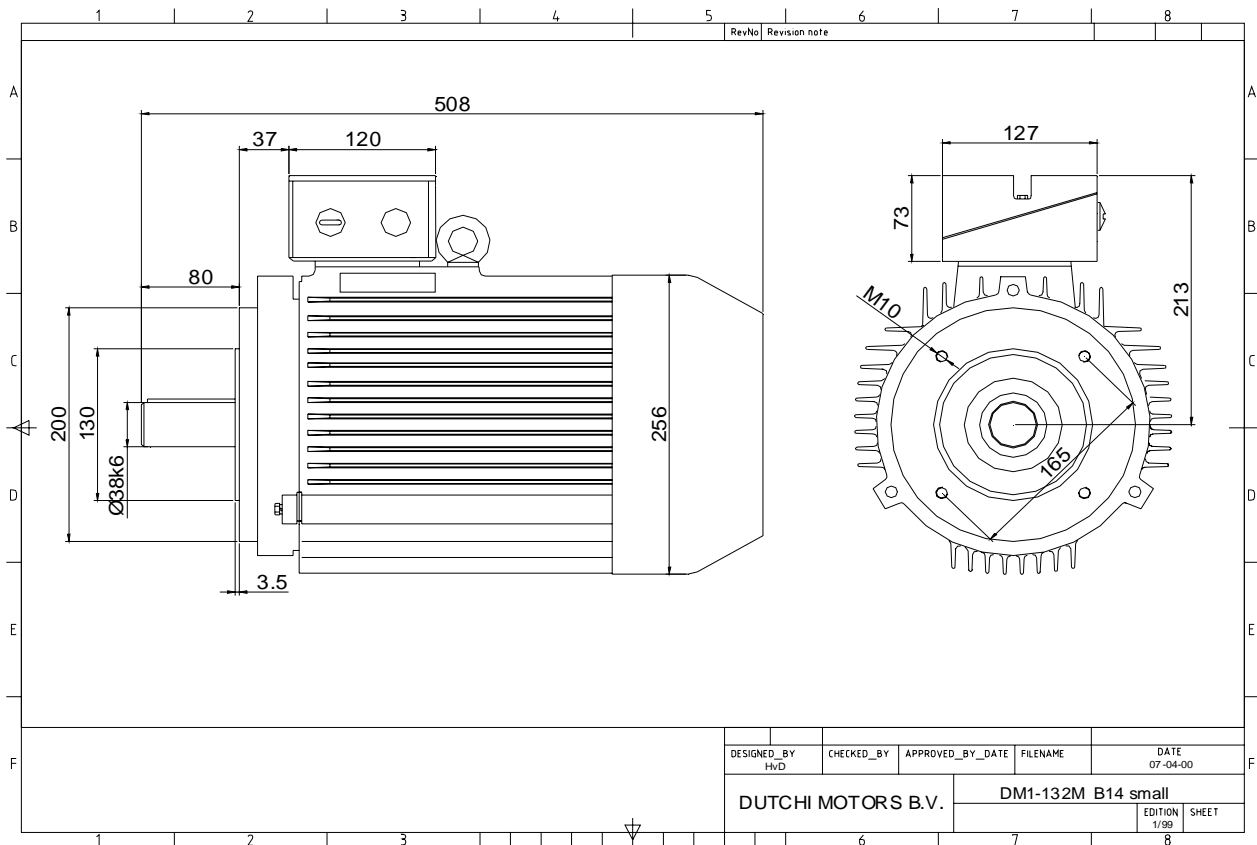

Specification **IEC 60034-1**  
 Manufacturer **Dutchi Motors B.V.**  
 Motor type **DM1- 132 M8**  
 Rated power **3** kW **S1** duty  
 Speed **710** r.p.m  
 Voltage **400 / 690** V  
 Frequency **50** Hz  
 Connection **Δ / Y**  
 Amps full load **7,31 / 4,22** A  
 Amps no-load(400V) **5,00** A  
 Enclosure **IP 55**  
 Insulation Class **F (temp. rise B (80 K))**

Max. coolant temp. **40°C**  
 Max. altitude **1.000** mtr, above sea level  
 Comment **3 x PTC 150°C**  
 Cable entries **2 x M32x1,5 + 1 x M20x1,5 (ptc)**

Feature **Cast-iron motor**  
 Weight **66,0** kg  
 Catalog no. **11338300D**  
 Warranty **12~18 months**

Efficiency class **N/A**  
 Load data 100% 75% 50% 25%  
 Efficiency **80,7 81,2 78,6 68,0** %  
 Power factor **0,73 0,64 0,50 0,31**

Sound pressure level (1m) **44,4** dB(A)  
 Resistance R20 (open) **6,36** Ω  
 Resistance R20 **Δ 4,24** Ω

Full load torque **40,35** Nm  
 DOL Starting torque vs FL torque **1,96**  
 DOL Pull up torque vs FL torque **1,69**  
 DOL Pull out torque vs FL torque **3,05**  
 Star-Delta Starting torque vs FL torque **0,61**  
 Star-Delta Pull up torque vs FL torque **0,53**  
 Star-Delta Pull out torque vs FL torque **0,95**  
 DOL Starting current vs FL current **5,21**  
 Star Delta Starting current vs FL current **1,63**  
 Rotor Inertia **0,0380** kgm<sup>2</sup>

Bearing DE **6308 - ZZ C3**  
 Bearing NDE **6308 - ZZ C3**

WI	Change	date	sign.
<b>Dutchi Motors B.V.</b> P.O. Box 5390 NL-6802 EJ ARNHEM Tel : +31-(0)26 - 3541 600 Fax : +31-(0)26 - 3541 650		Description	date
		Drawing made by :	19-04-04
		<b>dutchi.motors@dutchi.nl</b> <b>www.dutchi.com</b>	

Power is our commodity, the world is our market !

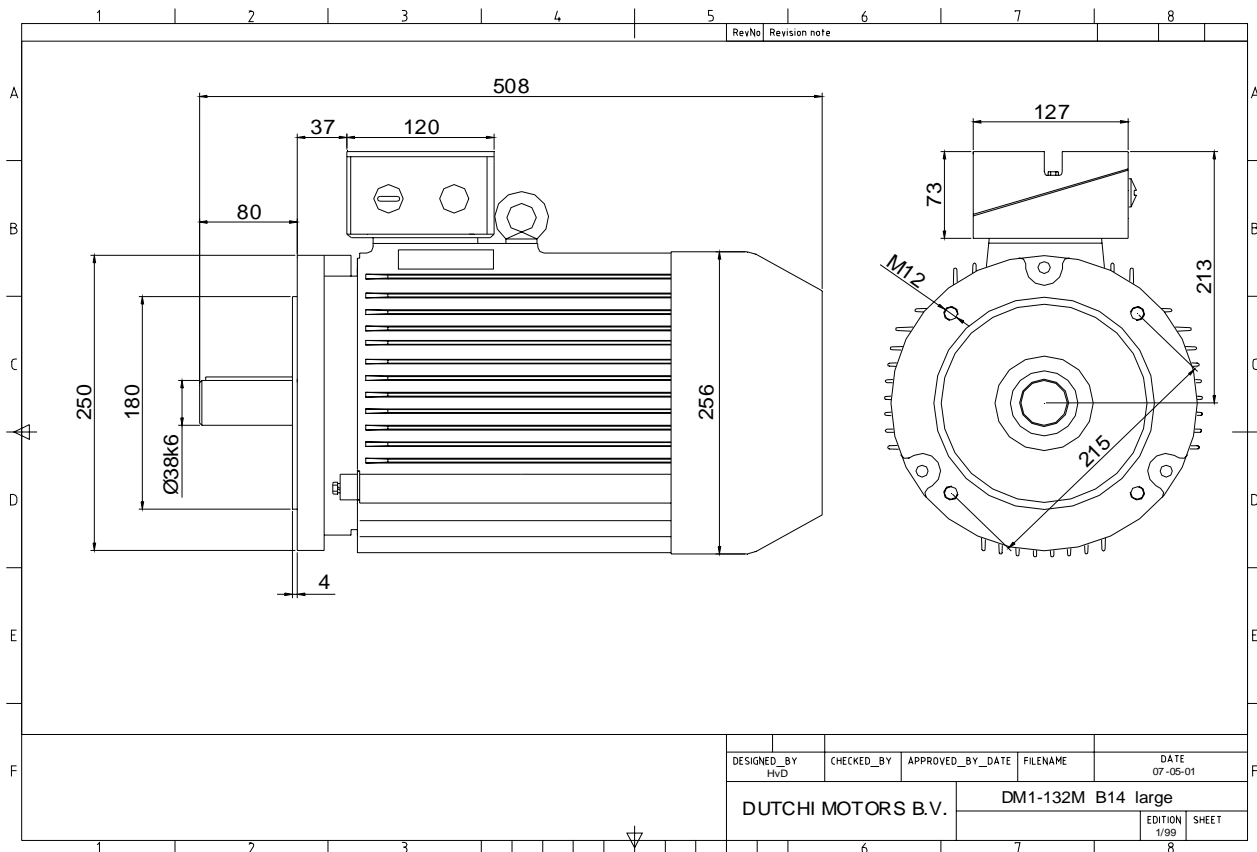

Specification **IEC 60034-1**  
 Manufacturer **Dutchi Motors B.V.**  
 Motor type **DM1- 132 M8**  
 Rated power **3** kW **S1** duty  
 Speed **710** r.p.m  
 Voltage **400 / 690** V  
 Frequency **50** Hz  
 Connection **Δ / Y**  
 Amps full load **7,31 / 4,22** A  
 Amps no-load(400V) **5,00** A  
 Enclosure **IP 55**  
 Insulation Class **F (temp. rise B (80 K))**

Max. coolant temp. **40°C**  
 Max. altitude **1.000** mtr, above sea level  
 Comment **3 x PTC 150°C**  
 Cable entries **2 x M32x1,5 + 1 x M20x1,5 (ptc)**

Feature **Cast-iron motor**  
 Weight **66,0** kg  
 Catalog no. **11438300D**  
 Warranty **12~18 months**

Efficiency class **N/A**  
 Load data 100% 75% 50% 25%  
 Efficiency **80,7 81,2 78,6 68,0** %  
 Power factor **0,73 0,64 0,50 0,31**

Sound pressure level (1m) **44,4** dB(A)  
 Resistance R20 (open) **6,36** Ω  
 Resistance R20 **Δ 4,24** Ω

Full load torque **40,35** Nm  
 DOL Starting torque vs FL torque **1,96**  
 DOL Pull up torque vs FL torque **1,69**  
 DOL Pull out torque vs FL torque **3,05**  
 Star-Delta Starting torque vs FL torque **0,61**  
 Star-Delta Pull up torque vs FL torque **0,53**  
 Star-Delta Pull out torque vs FL torque **0,95**  
 DOL Starting current vs FL current **5,21**  
 Star Delta Starting current vs FL current **1,63**  
 Rotor Inertia **0,0380** kgm<sup>2</sup>

Bearing DE **6308 - ZZ C3**  
 Bearing NDE **6308 - ZZ C3**

WI	Change	date	sign.
<b>Dutchi Motors B.V.</b> P.O. Box 5390 NL-6802 EJ ARNHEM Tel : +31-(0)26 - 3541 600 Fax : +31-(0)26 - 3541 650		Description	date
		Drawing made by :	19-04-04
		<b>dutchi.motors@dutchi.nl</b> <b>www.dutchi.com</b>	