

Power is our commodity, the world is our market !

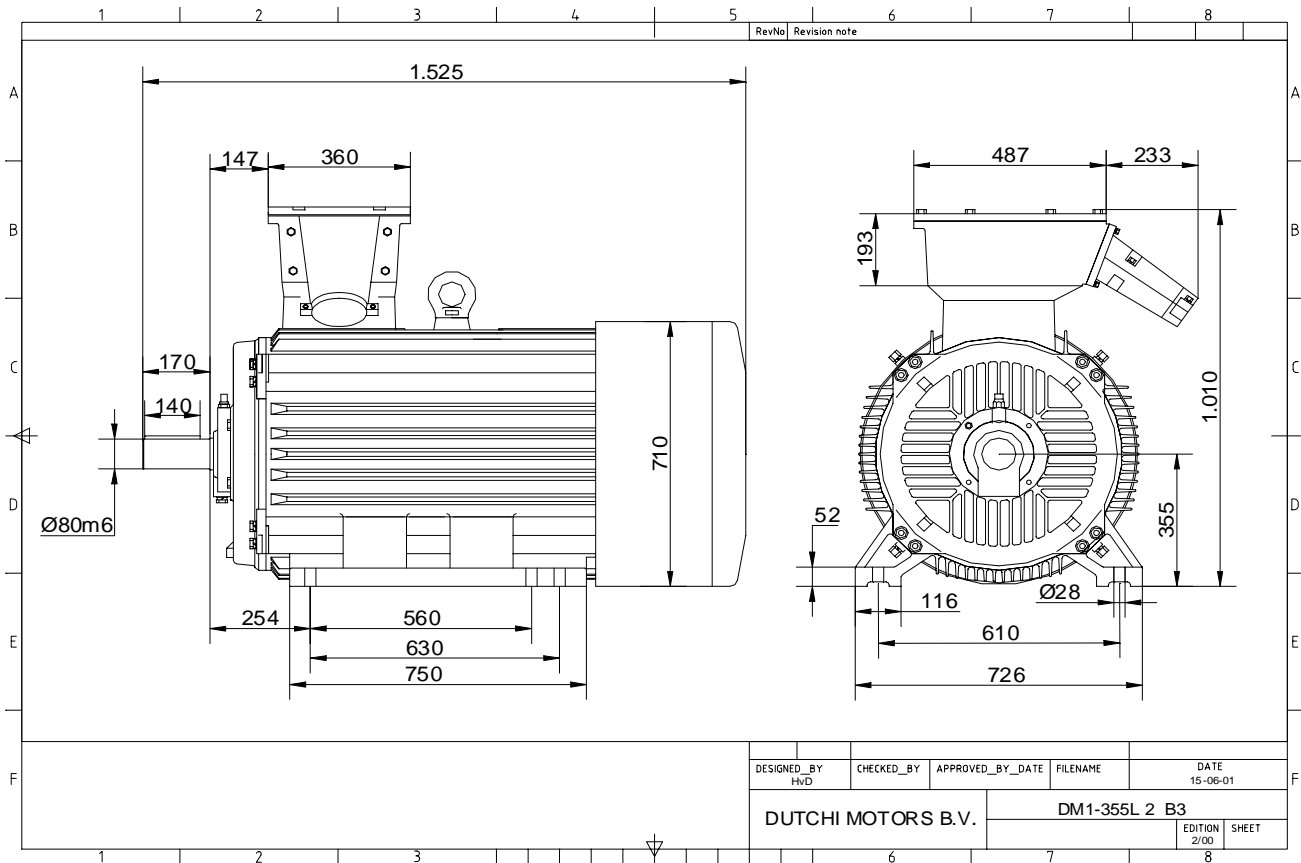

Specification	IEC 60034-1
Manufacturer	Dutchi Motors B.V.
Motor type	DM1- 355 LX2
Rated power	315 kW S1 duty
Speed	2985 r.p.m
Voltage	400 / 690 V
Frequency	50 Hz
Connection	Δ / Y
Amps full load	519 / 300 A
Amps no-load(400V)	103 A
Enclosure	IP 55
Insulation Class	F (temp. rise B (80 K))
Max. coolant temp.	40°C
Max. altitude	1.000 mtr, above sea level
Comment	3 x PTC 150°C
Cable entries	2 x Ø 70 mm + 1 x M20x1,5 (ptc)
Feature	Cast-iron motor
Weight	1850 kg
Catalog no.	11132D15D
Warranty	12~18 months

Efficiency class	N/A			
Load data	100%	75%	50%	25%
Efficiency	96,1	95,8	94,8	91,1 %
Power factor	0,91	0,92	0,88	0,69
Sound pressure level (1m)				96,0 dB(A)
Resistance R20 (open)				0,00570 Ω
Resistance R20	Δ			0,00380 Ω
Full load torque				1008 Nm
DOL Starting torque vs FL torque				1,70
DOL Pull up torque vs FL torque				1,50
DOL Pull out torque vs FL torque				4,05
Star-Delta Starting torque vs FL torque				0,53
Star-Delta Pull up torque vs FL torque				0,47
Star-Delta Pull out torque vs FL torque				1,27
DOL Starting current vs FL current				7,79
Star Delta Starting current vs FL current				2,43
Rotor Inertia				3,849 kgm ²
Bearing DE				6317 - C3 or NU317
Bearing NDE				6317 - C3 (IM V1 7317B)

WI	Change	date	sign.
Dutchi Motors B.V.		Description	date
P.O. Box 5390		Drawing made by :	27-04-04
NL-6802 EJ ARNHEM			
Tel : +31-(0)26 - 3541 600		dutchi.motors@dutchi.nl	
Fax : +31-(0)26 - 3541 650		www.dutchi.com	

Power is our commodity, the world is our market !

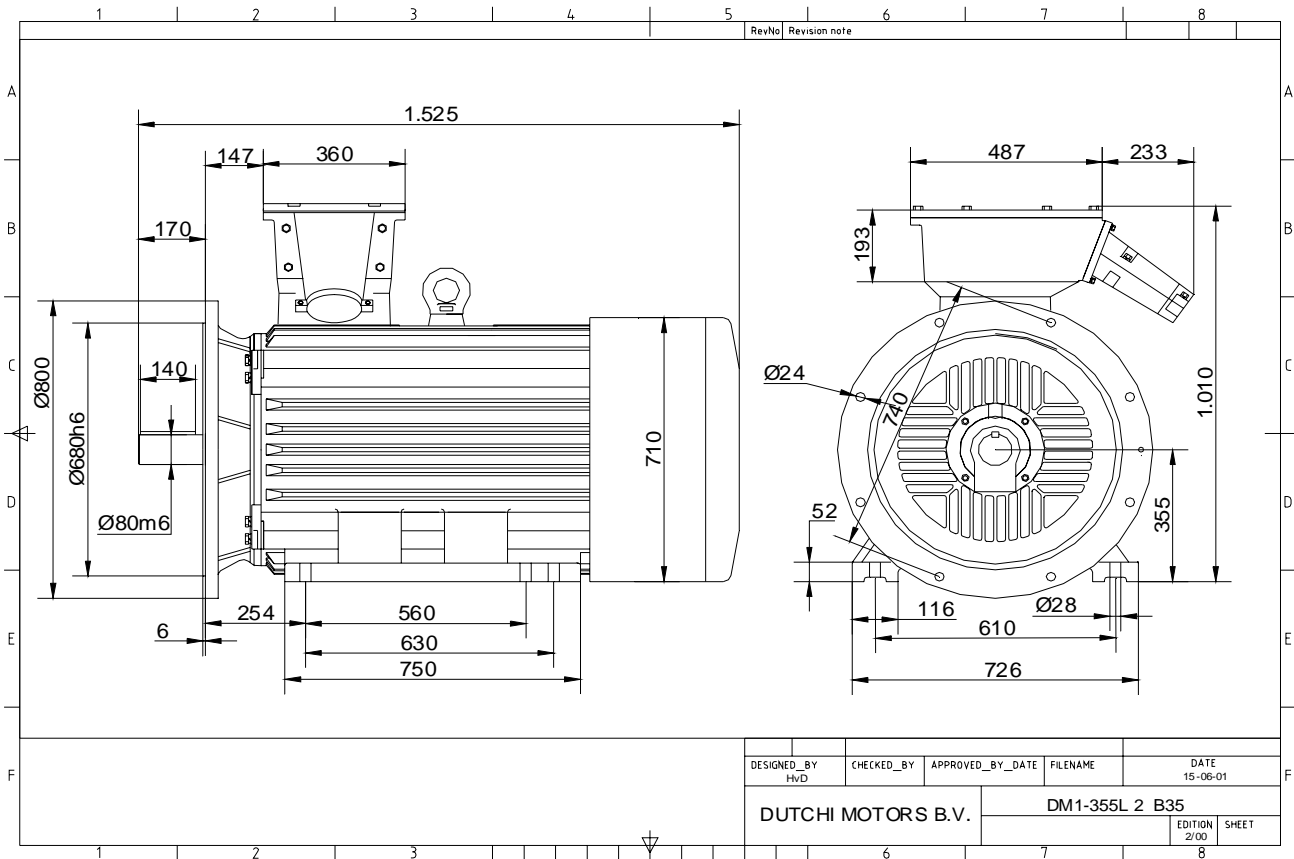

DESIGNED_BY HvD	CHECKED_BY	APPROVED_BY_DATE	FILENAME	DATE 15-06-01
DUTCHI MOTORS B.V.			DM1-355L 2 B35	EDITION 2/00
				SHEET

Specification	IEC 60034-1
Manufacturer	Dutchi Motors B.V.
Motor type	DM1- 355 LX2
Rated power	315 kW S1 duty
Speed	2985 r.p.m
Voltage	400 / 690 V
Frequency	50 Hz
Connection	Δ / Y
Amps full load	519 / 300 A
Amps no-load(400V)	103 A
Enclosure	IP 55
Insulation Class	F (temp. rise B (80 K))
Max. coolant temp.	40°C
Max. altitude	1.000 mtr, above sea level
Comment	3 x PTC 150°C
Cable entries	2 x Ø 70 mm + 1 x M20x1,5 (ptc)
Feature	Cast-iron motor
Weight	1850 kg
Catalog no.	11532D15D
Warranty	12~18 months

Efficiency class	N/A			
Load data	100%	75%	50%	25%
Efficiency	96,1	95,8	94,8	91,1 %
Power factor	0,91	0,92	0,88	0,69
Sound pressure level (1m)				96,0 dB(A)
Resistance R20 (open)				0,00570 Ω
Resistance R20	Δ			0,00380 Ω
Full load torque				1008 Nm
DOL Starting torque vs FL torque				1,70
DOL Pull up torque vs FL torque				1,50
DOL Pull out torque vs FL torque				4,05
Star-Delta Starting torque vs FL torque				0,53
Star-Delta Pull up torque vs FL torque				0,47
Star-Delta Pull out torque vs FL torque				1,27
DOL Starting current vs FL current				7,79
Star Delta Starting current vs FL current				2,43
Rotor Inertia				3,849 kgm ²
Bearing DE				6317 - C3 or NU317
Bearing NDE				6317 - C3 (IM V1 7317B)

WI	Change	date	sign.
Dutchi Motors B.V. P.O. Box 5390 NL-6802 EJ ARNHEM Tel : +31-(0)26 - 3541 600 Fax : +31-(0)26 - 3541 650		Discription Drawing made by :	date sign. HvD
dutchi.motors@dutchi.nl www.dutchi.com		27-04-04	

Power is our commodity, the world is our market !

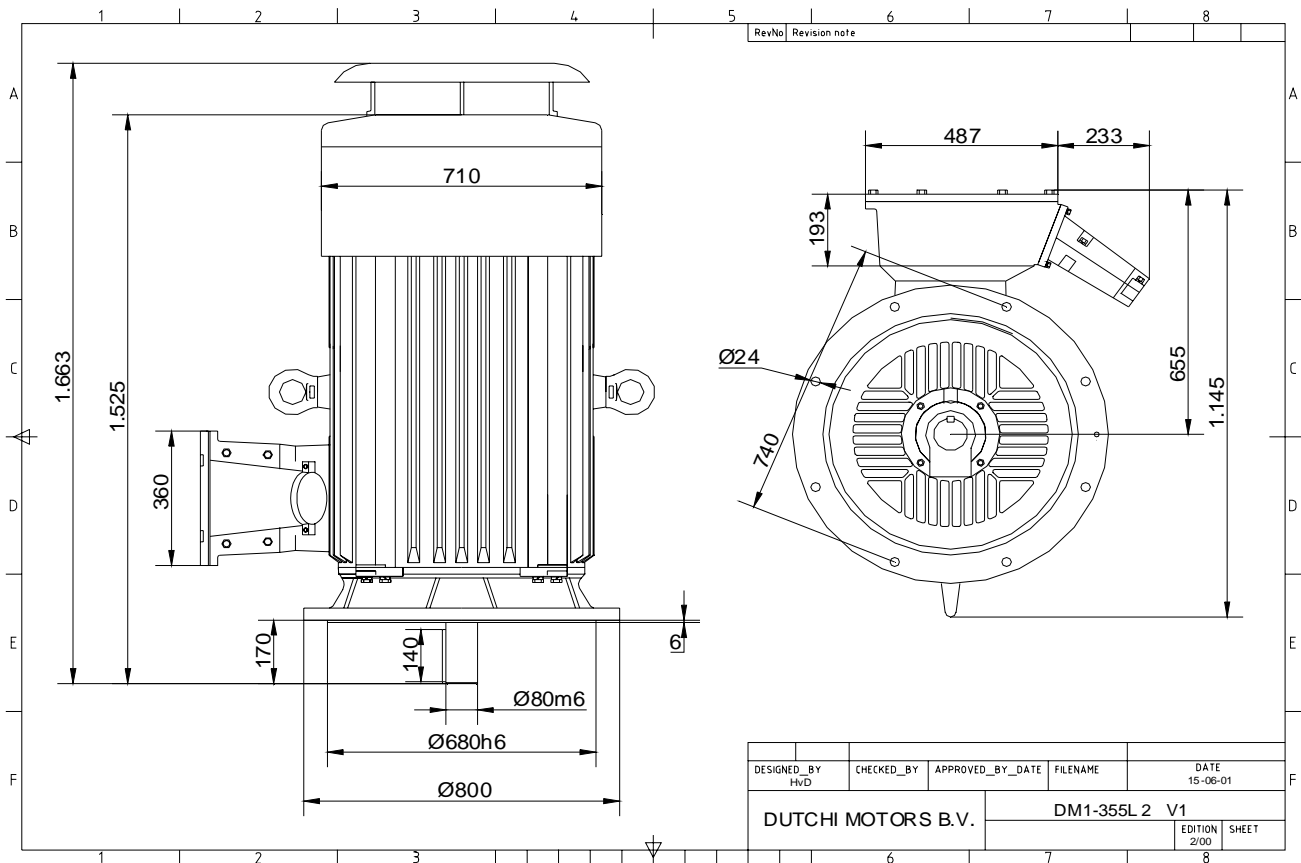

Specification	IEC 60034-1
Manufacturer	Dutchi Motors B.V.
Motor type	DM1- 355 LX2
Rated power	315 kW S1 duty
Speed	2985 r.p.m
Voltage	400 / 690 V
Frequency	50 Hz
Connection	Δ / Y
Amps full load	519 / 300 A
Amps no-load(400V)	103 A
Enclosure	IP 55
Insulation Class	F (temp. rise B (80 K))
Max. coolant temp.	40°C
Max. altitude	1.000 mtr, above sea level
Comment	3 x PTC 150°C
Cable entries	2 x Ø 70 mm + 1 x M20x1,5 (ptc)
Feature	Cast-iron motor
Weight	1850 kg
Catalog no.	11032D15D
Warranty	12~18 months

Efficiency class	N/A			
Load data	100%	75%	50%	25%
Efficiency	96,1	95,8	94,8	91,1 %
Power factor	0,91	0,92	0,88	0,69
Sound pressure level (1m)				96,0 dB(A)
Resistance R20 (open)				0,00570 Ω
Resistance R20	Δ			0,00380 Ω
Full load torque				1008 Nm
DOL Starting torque vs FL torque				1,70
DOL Pull up torque vs FL torque				1,50
DOL Pull out torque vs FL torque				4,05
Star-Delta Starting torque vs FL torque				0,53
Star-Delta Pull up torque vs FL torque				0,47
Star-Delta Pull out torque vs FL torque				1,27
DOL Starting current vs FL current				7,79
Star Delta Starting current vs FL current				2,43
Rotor Inertia				3,849 kgm ²
Bearing DE				6317 - C3 or NU317
Bearing NDE				6317 - C3 (IM V1 7317B)

WI	Change	date	sign.
Dutchi Motors B.V. P.O. Box 5390 NL-6802 EJ ARNHEM Tel : +31-(0)26 - 3541 600 Fax : +31-(0)26 - 3541 650		Discription Drawing made by :	date 27-04-04
		sign.	HvD
		dutchi.motors@dutchi.nl www.dutchi.com	