

Power is our commodity, the world is our market !

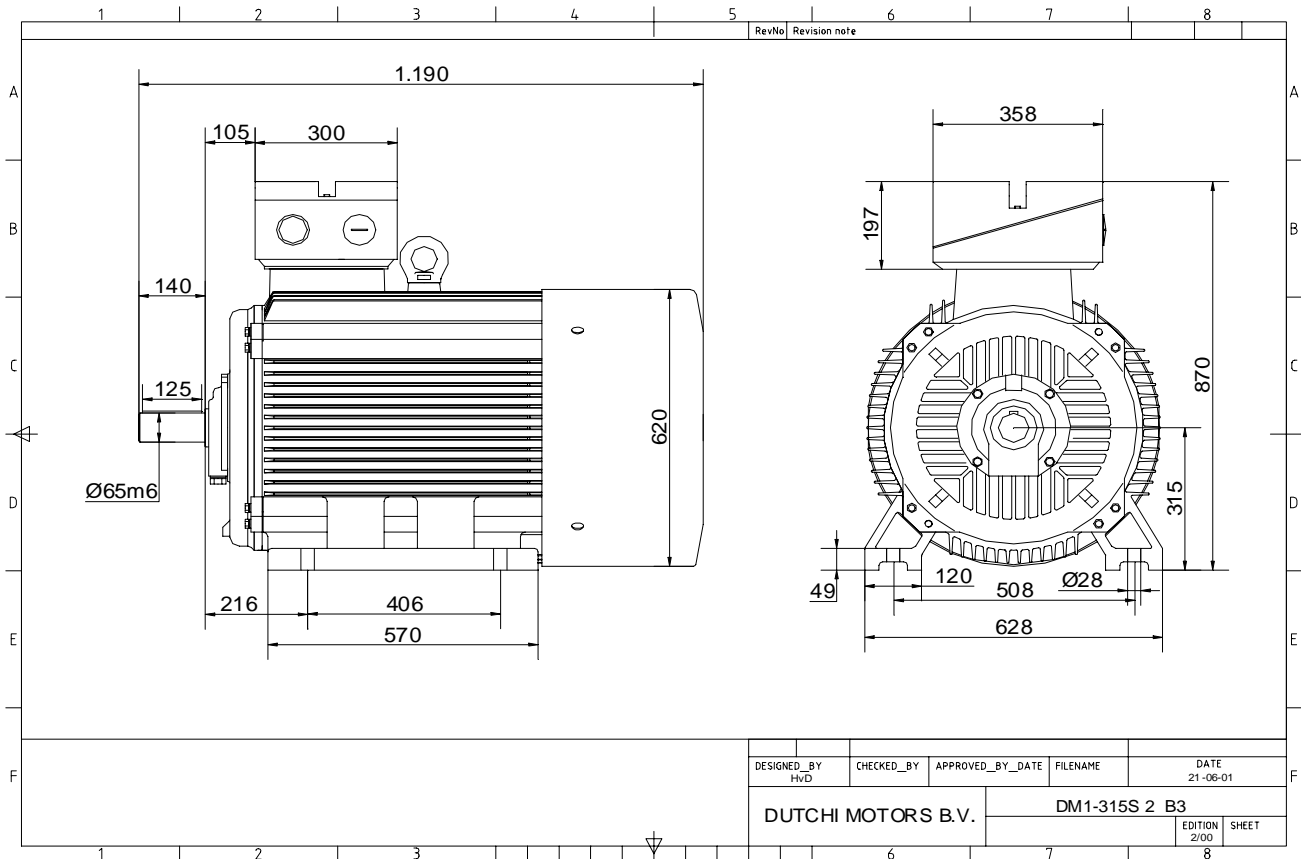

Specification	<b>IEC 60034-1</b>
Manufacturer	<b>Dutchi Motors B.V.</b>
Motor type	<b>DM1- 315 S2</b>
Rated power	<b>110</b> kW <b>S1</b> duty
Speed	<b>2975</b> r.p.m
Voltage	<b>400</b> / <b>690</b> V
Frequency	<b>50</b> Hz
Connection	<b>Δ</b> / <b>Y</b>
Amps full load	<b>184</b> / <b>106</b> A
Amps no-load(400V)	<b>42,90</b> A
Enclosure	<b>IP 55</b>
Insulation Class	<b>F (temp. rise B (80 K))</b>
Max. coolant temp.	<b>40°C</b>
Max. altitude	<b>1.000</b> mtr, above sea level
Comment	<b>3 x PTC 150°C</b>
Cable entries	<b>2 x M63x1,5 + 1 x M20x1,5 (ptc)</b>
Feature	<b>Cast-iron motor</b>
Weight	<b>920</b> kg
Catalog no.	<b>11132B10D</b>
Warranty	<b>12~18 months</b>

Efficiency class	<b>N/A</b>			
Load data	100%	75%	50%	25%
Efficiency	<b>93,8</b>	<b>93,0</b>	<b>91,0</b>	<b>84,7</b> %
Power factor	<b>0,92</b>	<b>0,91</b>	<b>0,87</b>	<b>0,72</b>
Sound pressure level (1m)				<b>91,0</b> dB(A)
Resistance R20 (open)				<b>0,0280</b> Ω
Resistance R20	<b>Δ</b>			<b>0,0187</b> Ω
Full load torque				<b>353</b> Nm
DOL Starting torque vs FL torque				<b>1,67</b>
DOL Pull up torque vs FL torque				<b>1,30</b>
DOL Pull out torque vs FL torque				<b>2,93</b>
Star-Delta Starting torque vs FL torque				<b>0,52</b>
Star-Delta Pull up torque vs FL torque				<b>0,41</b>
Star-Delta Pull out torque vs FL torque				<b>0,91</b>
DOL Starting current vs FL current				<b>5,90</b>
Star Delta Starting current vs FL current				<b>1,84</b>
Rotor Inertia				<b>1,1300</b> kgm <sup>2</sup>
Bearing DE				<b>6317 - C3 or NU317</b>
Bearing NDE				<b>6317 - C3 (IM V1 7317B)</b>

WI	Change	date	sign.
<b>Dutchi Motors B.V.</b> P.O. Box 5390 NL-6802 EJ ARNHEM Tel : +31-(0)26 - 3541 600 Fax : +31-(0)26 - 3541 650		Discription	date
		Drawing made by :	27-04-04
		<b>dutchi.motors@dutchi.nl</b> <b>www.dutchi.com</b>	

Power is our commodity, the world is our market !

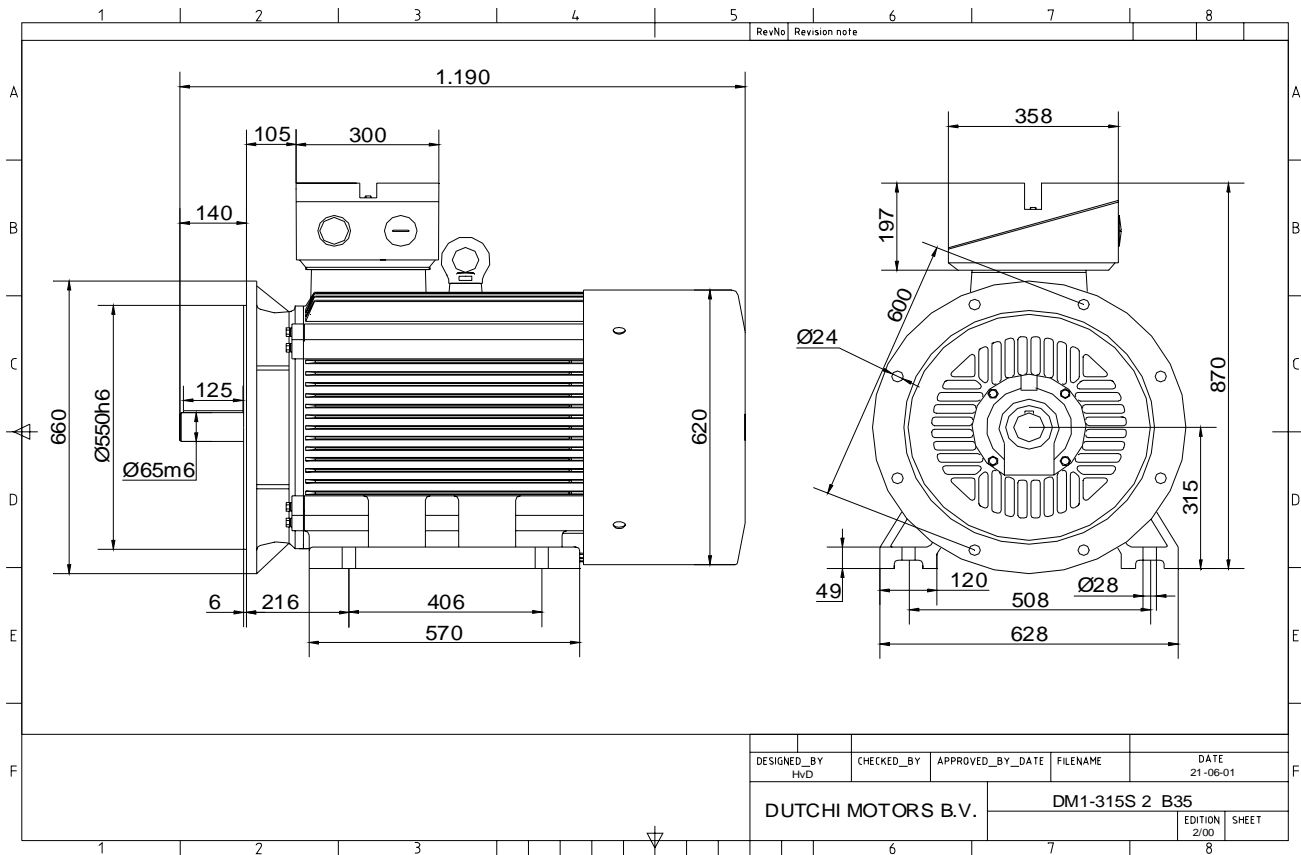

Specification	<b>IEC 60034-1</b>
Manufacturer	<b>Dutchi Motors B.V.</b>
Motor type	<b>DM1- 315 S2</b>
Rated power	<b>110</b> kW <b>S1</b> duty
Speed	<b>2975</b> r.p.m
Voltage	<b>400</b> / <b>690</b> V
Frequency	<b>50</b> Hz
Connection	<b>Δ</b> / <b>Y</b>
Amps full load	<b>184</b> / <b>106</b> A
Amps no-load(400V)	<b>42,90</b> A
Enclosure	<b>IP 55</b>
Insulation Class	<b>F (temp. rise B (80 K))</b>
Max. coolant temp.	<b>40°C</b>
Max. altitude	<b>1.000</b> mtr, above sea level
Comment	<b>3 x PTC 150°C</b>
Cable entries	<b>2 x M63x1,5 + 1 x M20x1,5 (ptc)</b>
Feature	<b>Cast-iron motor</b>
Weight	<b>920</b> kg
Catalog no.	<b>11532B10D</b>
Warranty	<b>12~18 months</b>

Efficiency class	<b>N/A</b>			
Load data	100%	75%	50%	25%
Efficiency	<b>93,8</b>	<b>93,0</b>	<b>91,0</b>	<b>84,7</b> %
Power factor	<b>0,92</b>	<b>0,91</b>	<b>0,87</b>	<b>0,72</b>
Sound pressure level (1m)				<b>91,0</b> dB(A)
Resistance R20 (open)				<b>0,0280</b> Ω
Resistance R20	<b>Δ</b>			<b>0,0187</b> Ω
Full load torque				<b>353</b> Nm
DOL Starting torque vs FL torque				<b>1,67</b>
DOL Pull up torque vs FL torque				<b>1,30</b>
DOL Pull out torque vs FL torque				<b>2,93</b>
Star-Delta Starting torque vs FL torque				<b>0,52</b>
Star-Delta Pull up torque vs FL torque				<b>0,41</b>
Star-Delta Pull out torque vs FL torque				<b>0,91</b>
DOL Starting current vs FL current				<b>5,90</b>
Star Delta Starting current vs FL current				<b>1,84</b>
Rotor Inertia				<b>1,1300</b> kgm <sup>2</sup>
Bearing DE				<b>6317 - C3 or NU317</b>
Bearing NDE				<b>6317 - C3 (IM V1 7317B)</b>

WI	Change	date	sign.
<b>Dutchi Motors B.V.</b> P.O. Box 5390 NL-6802 EJ ARNHEM Tel : +31-(0)26 - 3541 600 Fax : +31-(0)26 - 3541 650		Discription Drawing made by :	date 27-04-04
dutchi.motors@dutchi.nl www.dutchi.com		sign. HvD	

Power is our commodity, the world is our market !

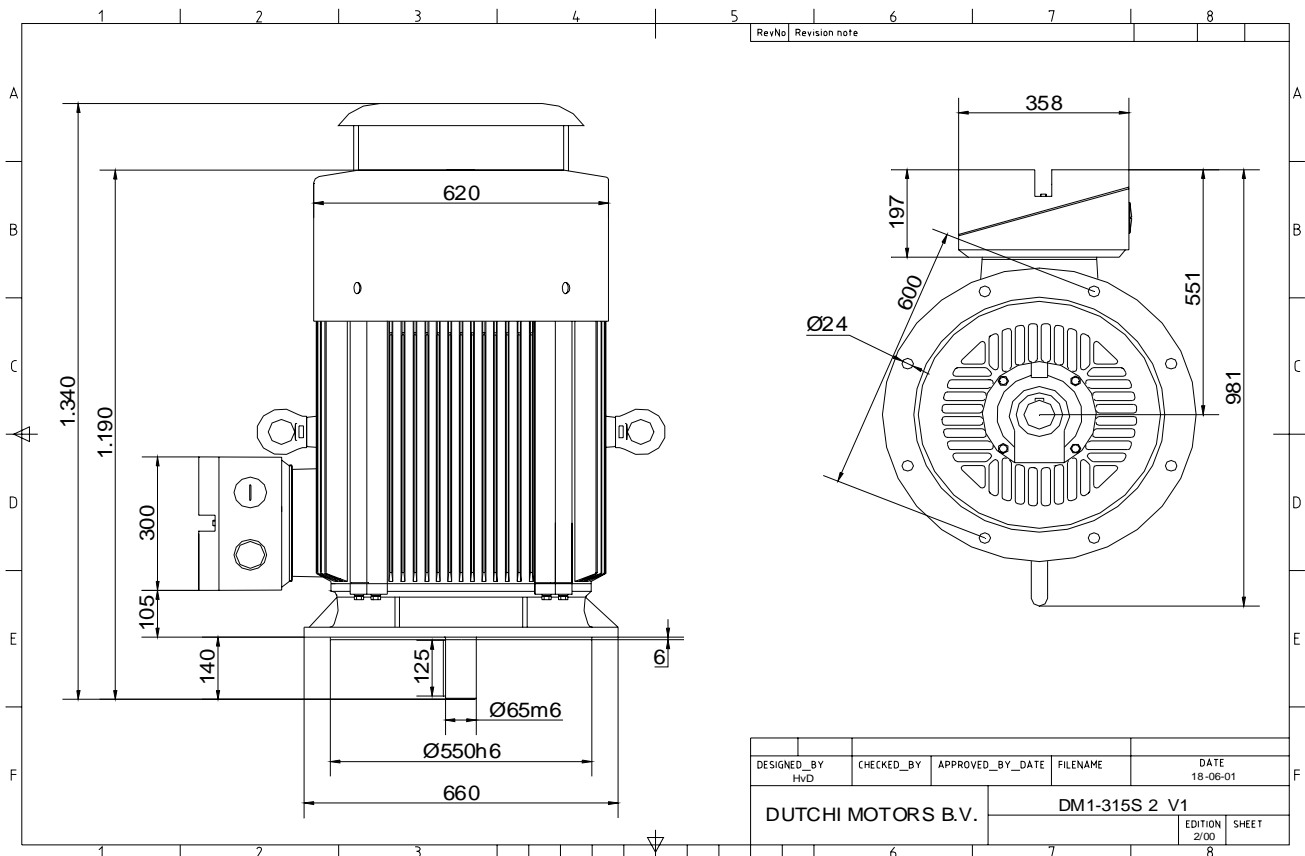

Specification	<b>IEC 60034-1</b>
Manufacturer	<b>Dutchi Motors B.V.</b>
Motor type	<b>DM1- 315 S2</b>
Rated power	<b>110</b> kW <b>S1</b> duty
Speed	<b>2975</b> r.p.m
Voltage	<b>400</b> / <b>690</b> V
Frequency	<b>50</b> Hz
Connection	<b>Δ</b> / <b>Y</b>
Amps full load	<b>184</b> / <b>106</b> A
Amps no-load(400V)	<b>42,90</b> A
Enclosure	<b>IP 55</b>
Insulation Class	<b>F (temp. rise B (80 K))</b>
Max. coolant temp.	<b>40°C</b>
Max. altitude	<b>1.000</b> mtr, above sea level
Comment	<b>3 x PTC 150°C</b>
Cable entries	<b>2 x M63x1,5 + 1 x M20x1,5 (ptc)</b>
Feature	<b>Cast-iron motor</b>
Weight	<b>920</b> kg
Catalog no.	<b>11032B10D</b>
Warranty	<b>12~18 months</b>

Efficiency class	<b>N/A</b>			
Load data	100%	75%	50%	25%
Efficiency	<b>93,8</b>	<b>93,0</b>	<b>91,0</b>	<b>84,7</b> %
Power factor	<b>0,92</b>	<b>0,91</b>	<b>0,87</b>	<b>0,72</b>
Sound pressure level (1m)				<b>91,0</b> dB(A)
Resistance R20 (open)				<b>0,0280</b> Ω
Resistance R20	<b>Δ</b>			<b>0,0187</b> Ω
Full load torque				<b>353</b> Nm
DOL Starting torque vs FL torque				<b>1,67</b>
DOL Pull up torque vs FL torque				<b>1,30</b>
DOL Pull out torque vs FL torque				<b>2,93</b>
Star-Delta Starting torque vs FL torque				<b>0,52</b>
Star-Delta Pull up torque vs FL torque				<b>0,41</b>
Star-Delta Pull out torque vs FL torque				<b>0,91</b>
DOL Starting current vs FL current				<b>5,90</b>
Star Delta Starting current vs FL current				<b>1,84</b>
Rotor Inertia				<b>1,1300</b> kgm <sup>2</sup>
Bearing DE				<b>6317 - C3 or NU317</b>
Bearing NDE				<b>6317 - C3 (IM V1 7317B)</b>

WI	Change	date	sign.
<b>Dutchi Motors B.V.</b> P.O. Box 5390 NL-6802 EJ ARNHEM Tel : +31-(0)26 - 3541 600 Fax : +31-(0)26 - 3541 650		Discription Drawing made by :	date sign. HvD
dutchi.motors@dutchi.nl www.dutchi.com		27-04-04	