

Power is our commodity, the world is our market !

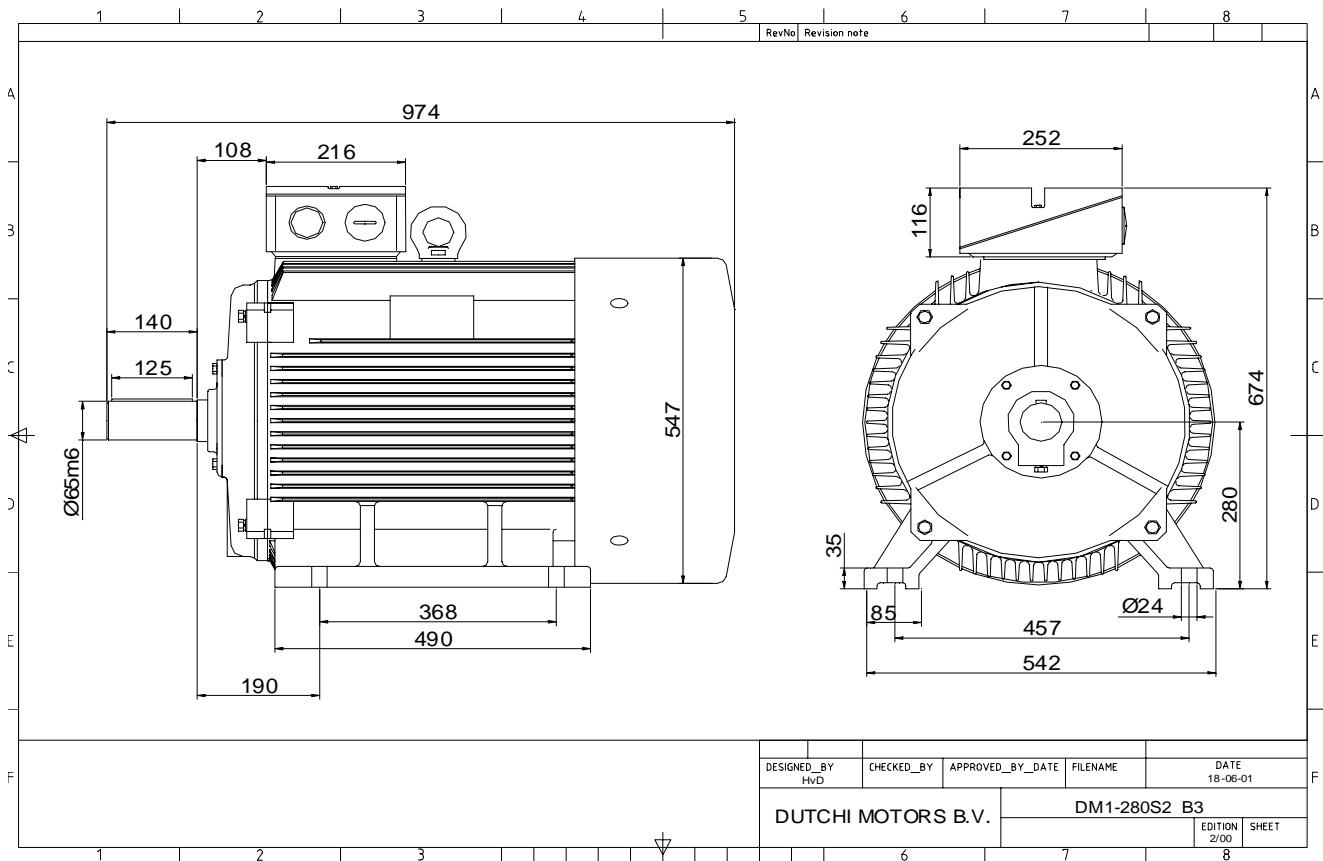

Specification **IEC 60034-1**
 Manufacturer **Dutchi Motors B.V.**
 Motor type **DM1- 280 S2**
 Rated power **75** kW **S1** duty
 Speed **2965** r.p.m
 Voltage **400** / **690** V
 Frequency **50** Hz
 Connection **Δ** / **Y**
 Amps full load **126** / **72,9** A
 Amps no-load(400V) **30,30** A
 Enclosure **IP 55**
 Insulation Class **F (temp. rise B (80 K))**

Max. coolant temp. **40°C**
 Max. altitude **1.000** mtr, above sea level
 Comment **3 x PTC 150°C**
 Cable entries **2 x M63x1,5 + 1 x M20x1,5 (ptc)**

Feature **Cast-iron motor**
 Weight **510** kg
 Catalog no. **11132A75D**
 Warranty **12~18 months**

Efficiency class **EFF 2**
 Load data 100% 75% 50% 25%
 Efficiency **93,9 93,7 92,4 87,1** %
 Power factor **0,91 0,94 0,89 0,60**

Sound pressure level (1m) **83,8** dB(A)
 Resistance R20 (open) **0,066** Ω
 Resistance R20 **Δ 0,044** Ω

Full load torque **242** Nm
 DOL Starting torque vs FL torque **2,42**
 DOL Pull up torque vs FL torque **1,73**
 DOL Pull out torque vs FL torque **3,38**
 Star-Delta Starting torque vs FL torque **0,76**
 Star-Delta Pull up torque vs FL torque **0,54**
 Star-Delta Pull out torque vs FL torque **1,05**
 DOL Starting current vs FL current **7,15**
 Star Delta Starting current vs FL current **2,23**
 Rotor Inertia **0,5840** kgm2

Bearing DE **6314 - C3 or NU314**
 Bearing NDE **6314 - C3**

WI	Change	date	sign.
Dutchi Motors B.V.		Description	date
P.O. Box 5390		Drawing made by :	27-04-04
NL-6802 EJ ARNHEM			
Tel : +31-(0)26 - 3541 600		dutchi.motors@dutchi.nl	
Fax : +31-(0)26 - 3541 650		www.dutchi.com	

Power is our commodity, the world is our market !

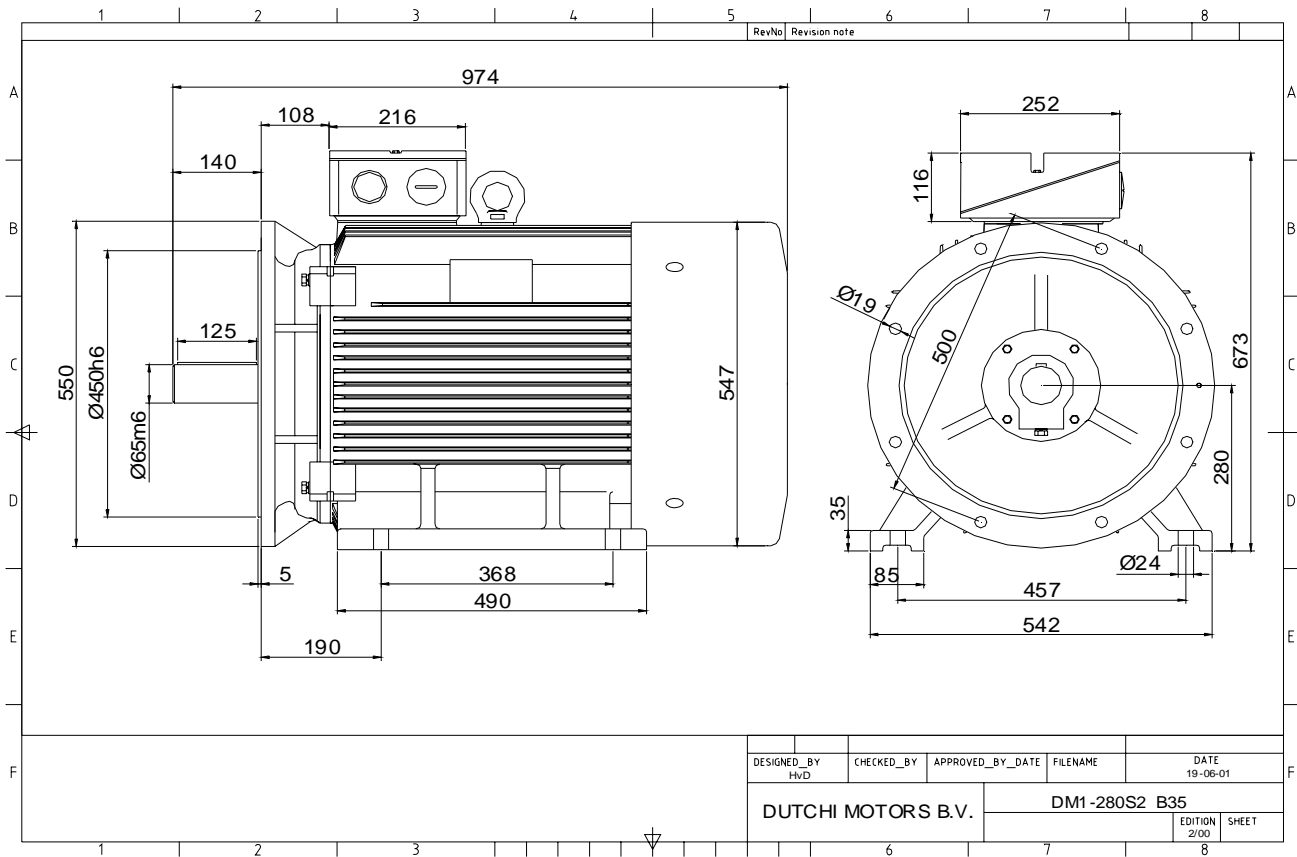

Specification **IEC 60034-1**
 Manufacturer **Dutchi Motors B.V.**
 Motor type **DM1- 280 S2**
 Rated power **75** kW **S1** duty
 Speed **2965** r.p.m
 Voltage **400 / 690** V
 Frequency **50** Hz
 Connection **Δ / Y**
 Amps full load **126 / 72,9** A
 Amps no-load(400V) **30,30** A
 Enclosure **IP 55**
 Insulation Class **F (temp. rise B (80 K))**

Max. coolant temp. **40°C**
 Max. altitude **1.000** mtr, above sea level
 Comment **3 x PTC 150°C**
 Cable entries **2 x M63x1,5 + 1 x M20x1,5 (ptc)**

Feature **Cast-iron motor**
 Weight **510** kg
 Catalog no. **11532A75D**
 Warranty **12~18 months**

Efficiency class **EFF 2**
 Load data 100% 75% 50% 25%
 Efficiency **93,9 93,7 92,4 87,1** %
 Power factor **0,91 0,94 0,89 0,60**

Sound pressure level (1m) **83,8** dB(A)
 Resistance R20 (open) **0,066** Ω
 Resistance R20 **Δ 0,044** Ω

Full load torque **242** Nm
 DOL Starting torque vs FL torque **2,42**
 DOL Pull up torque vs FL torque **1,73**
 DOL Pull out torque vs FL torque **3,38**
 Star-Delta Starting torque vs FL torque **0,76**
 Star-Delta Pull up torque vs FL torque **0,54**
 Star-Delta Pull out torque vs FL torque **1,05**
 DOL Starting current vs FL current **7,15**
 Star Delta Starting current vs FL current **2,23**
 Rotor Inertia **0,5840** kgm2

Bearing DE **6314 - C3 or NU314**
 Bearing NDE **6314 - C3**

WI	Change	date	sign.
Dutchi Motors B.V. P.O. Box 5390 NL-6802 EJ ARNHEM Tel : +31-(0)26 - 3541 600 Fax : +31-(0)26 - 3541 650		Discription Drawing made by : 27-04-04	date sign. HvD
dutchi.motors@dutchi.nl www.dutchi.com			

Power is our commodity, the world is our market !

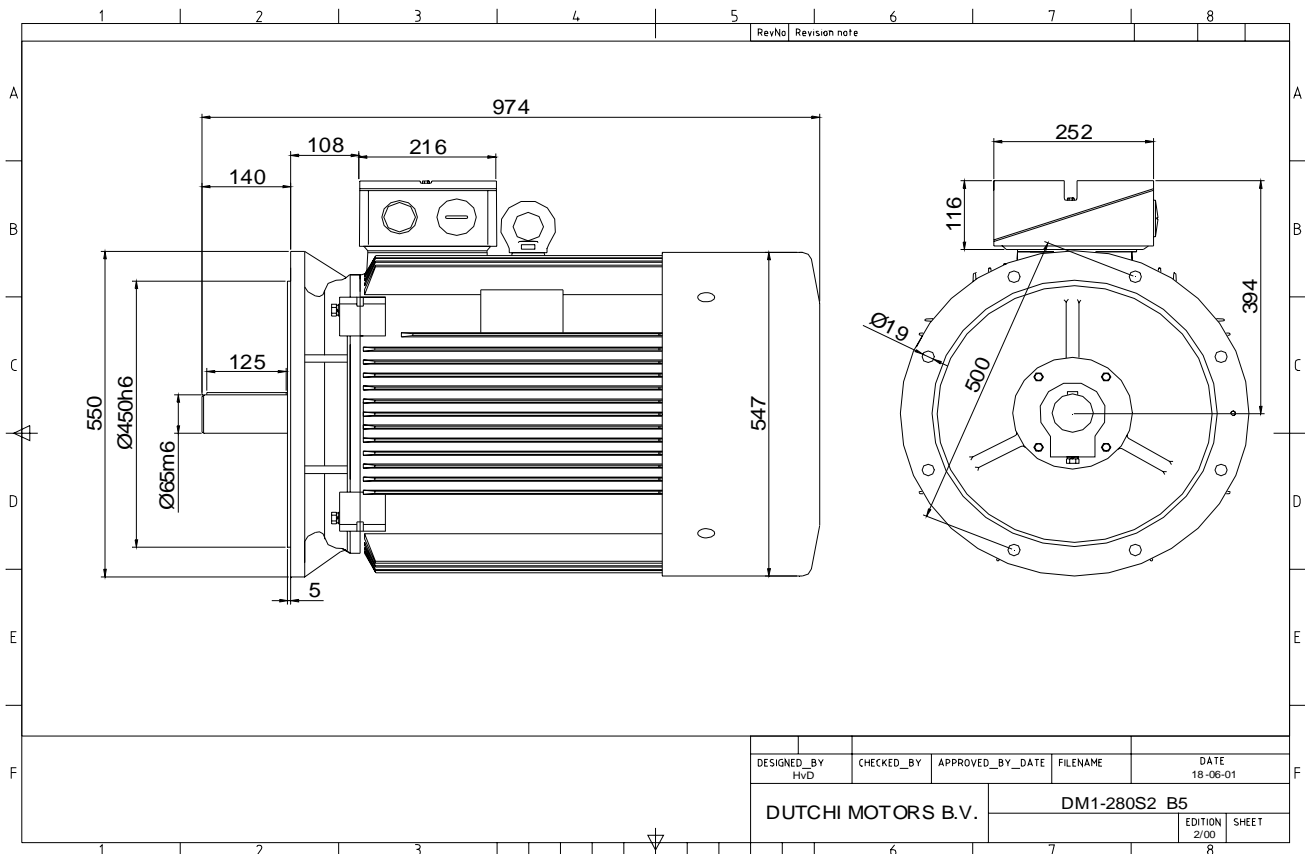

Specification	IEC 60034-1
Manufacturer	Dutchi Motors B.V.
Motor type	DM1- 280 S2
Rated power	75 kW S1 duty
Speed	2965 r.p.m
Voltage	400 / 690 V
Frequency	50 Hz
Connection	Δ / Y
Amps full load	126 / 72,9 A
Amps no-load(400V)	30,30 A
Enclosure	IP 55
Insulation Class	F (temp. rise B (80 K))
Max. coolant temp.	40°C
Max. altitude	1.000 mtr, above sea level
Comment	3 x PTC 150°C
Cable entries	2 x M63x1,5 + 1 x M20x1,5 (ptc)
Feature	Cast-iron motor
Weight	510 kg
Catalog no.	11232A75D
Warranty	12~18 months

Efficiency class	EFF 2			
Load data	100%	75%	50%	25%
Efficiency	93,9	93,7	92,4	87,1 %
Power factor	0,91	0,94	0,89	0,60
Sound pressure level (1m)				83,8 dB(A)
Resistance R20 (open)				0,066 Ω
Resistance R20	Δ			0,044 Ω
Full load torque				242 Nm
DOL Starting torque vs FL torque				2,42
DOL Pull up torque vs FL torque				1,73
DOL Pull out torque vs FL torque				3,38
Star-Delta Starting torque vs FL torque				0,76
Star-Delta Pull up torque vs FL torque				0,54
Star-Delta Pull out torque vs FL torque				1,05
DOL Starting current vs FL current				7,15
Star Delta Starting current vs FL current				2,23
Rotor Inertia				0,5840 kgm ²
Bearing DE				6314 - C3 or NU314
Bearing NDE				6314 - C3

WI	Change	date	sign.
Dutchi Motors B.V. P.O. Box 5390 NL-6802 EJ ARNHEM Tel : +31-(0)26 - 3541 600 Fax : +31-(0)26 - 3541 650		Discription Drawing made by :	date sign. HvD
dutchi.motors@dutchi.nl www.dutchi.com		27-04-04	

Power is our commodity, the world is our market !

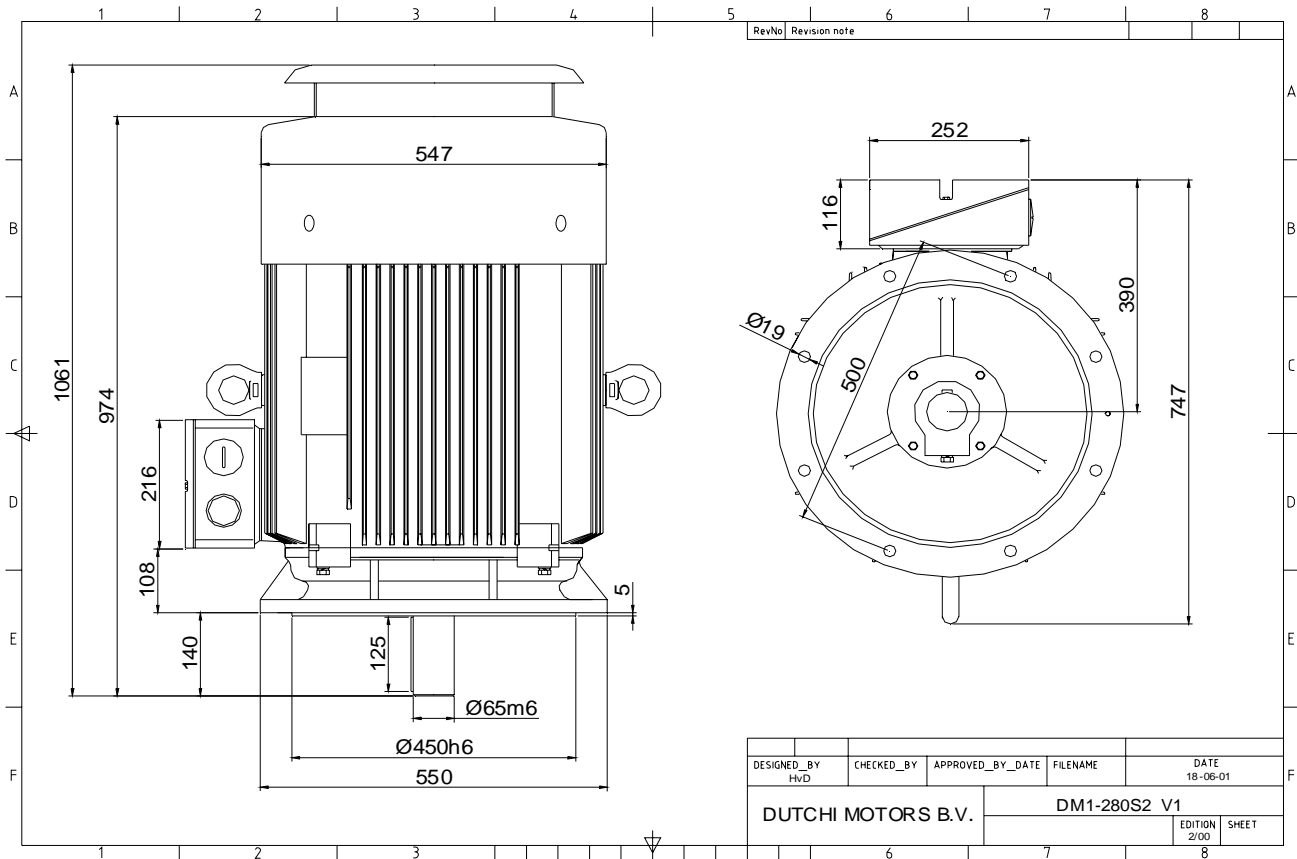

Specification	IEC 60034-1
Manufacturer	Dutchi Motors B.V.
Motor type	DM1- 280 S2
Rated power	75 kW S1 duty
Speed	2965 r.p.m
Voltage	400 / 690 V
Frequency	50 Hz
Connection	Δ / Y
Amps full load	126 / 72,9 A
Amps no-load(400V)	30,30 A
Enclosure	IP 55
Insulation Class	F (temp. rise B (80 K))
Max. coolant temp.	40°C
Max. altitude	1.000 mtr, above sea level
Comment	3 x PTC 150°C
Cable entries	2 x M63x1,5 + 1 x M20x1,5 (ptc)
Feature	Cast-iron motor
Weight	510 kg
Catalog no.	11032A75D
Warranty	12~18 months

Efficiency class	EFF 2			
Load data	100%	75%	50%	25%
Efficiency	93,9	93,7	92,4	87,1 %
Power factor	0,91	0,94	0,89	0,60
Sound pressure level (1m)				83,8 dB(A)
Resistance R20 (open)				0,066 Ω
Resistance R20	Δ			0,044 Ω
Full load torque				242 Nm
DOL Starting torque vs FL torque				2,42
DOL Pull up torque vs FL torque				1,73
DOL Pull out torque vs FL torque				3,38
Star-Delta Starting torque vs FL torque				0,76
Star-Delta Pull up torque vs FL torque				0,54
Star-Delta Pull out torque vs FL torque				1,05
DOL Starting current vs FL current				7,15
Star Delta Starting current vs FL current				2,23
Rotor Inertia				0,5840 kgm ²
Bearing DE				6314 - C3 or NU314
Bearing NDE				6314 - C3

WI	Change	date	sign.
Dutchi Motors B.V. P.O. Box 5390 NL-6802 EJ ARNHEM Tel : +31-(0)26 - 3541 600 Fax : +31-(0)26 - 3541 650		Discription Drawing made by :	date sign. HvD
dutchi.motors@dutchi.nl www.dutchi.com		27-04-04	