

Power is our commodity, the world is our market !

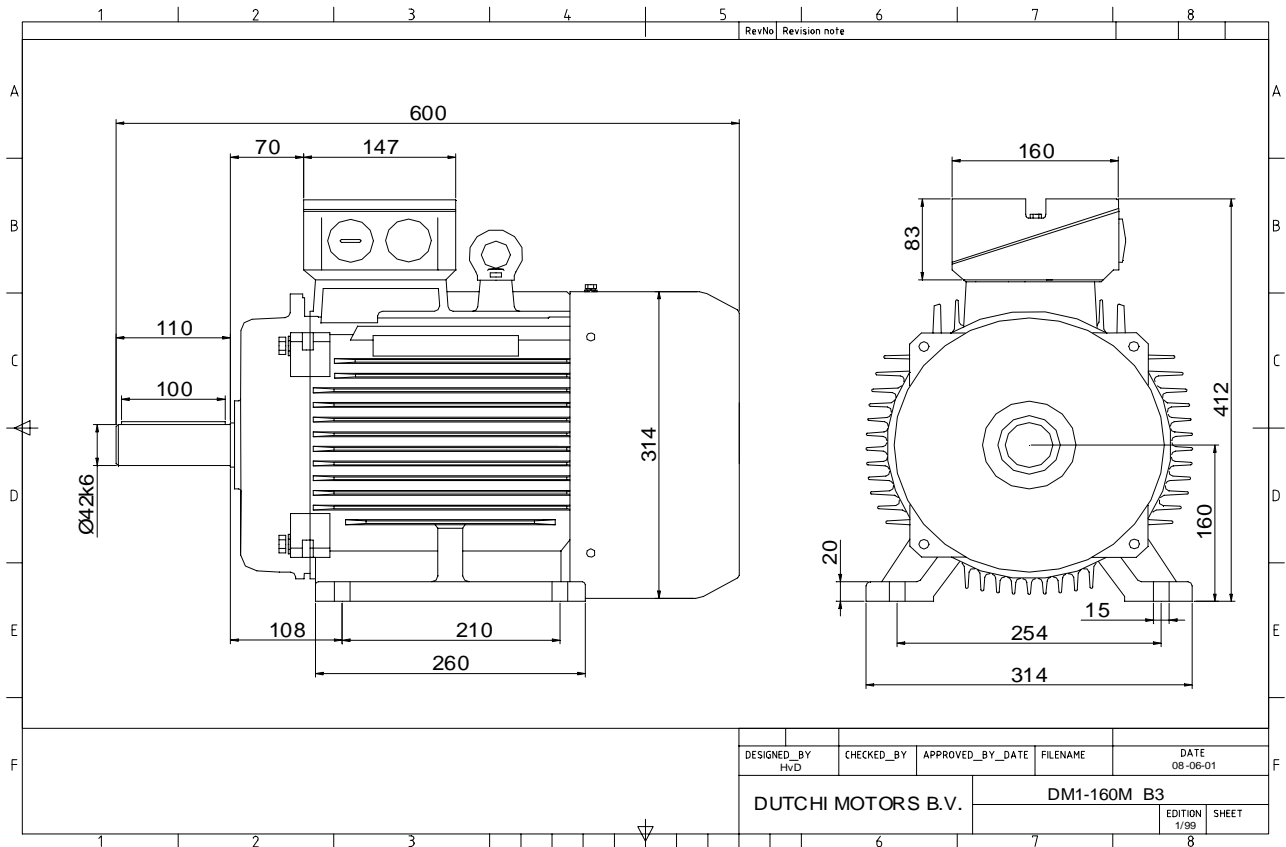

Specification **IEC 60034-1**
 Manufacturer **Dutchi Motors B.V.**
 Motor type **DM1- 160 M2**
 Rated power **11,00 kW S1** duty
 Speed **2935** r.p.m
 Voltage **400 / 690** V
 Frequency **50** Hz
 Connection **Δ / Y**
 Amps full load **20,18 / 11,65** A
 Amps no-load(400V) **6,21** A
 Enclosure **IP 55**
 Insulation Class **F (temp. rise B (80 K))**

Max. coolant temp. **40°C**
 Max. altitude **1.000** mtr, above sea level
 Comment **3 x PTC 150°C**
 Cable entries **2 x M40x1,5 + 1 x M20x1,5 (ptc)**

Feature **Cast-iron motor**
 Weight **107** kg
 Catalog no. **11132A11D**
 Warranty **12~18 months**

Efficiency class **EFF 2**
 Load data 100% 75% 50% 25%
 Efficiency **89,2 89,4 87,8 81,4** %
 Power factor **0,88 0,86 0,78 0,60**

Sound pressure level (1m) **78,5** dB(A)
 Resistance R20 (open) **0,856** Ω
 Resistance R20 **Δ 0,571** Ω

Full load torque **35,79** Nm
 DOL Starting torque vs FL torque **2,11**
 DOL Pull up torque vs FL torque **1,54**
 DOL Pull out torque vs FL torque **3,02**
 Star-Delta Starting torque vs FL torque **0,66**
 Star-Delta Pull up torque vs FL torque **0,48**
 Star-Delta Pull out torque vs FL torque **0,94**
 DOL Starting current vs FL current **6,58**
 Star Delta Starting current vs FL current **2,06**
 Rotor Inertia **0,0370** kgm²

Bearing DE **6309 - ZZ C3**
 Bearing NDE **6309 - ZZ C3**

WI	Change	date	sign.
Dutchi Motors B.V.		Discription	date
P.O. Box 5390		Drawing made by :	27-04-04
NL-6802 EJ ARNHEM			
Tel : +31-(0)26 - 3541 600		dutchi.motors@dutchi.nl	
Fax : +31-(0)26 - 3541 650		www.dutchi.com	

Power is our commodity, the world is our market !

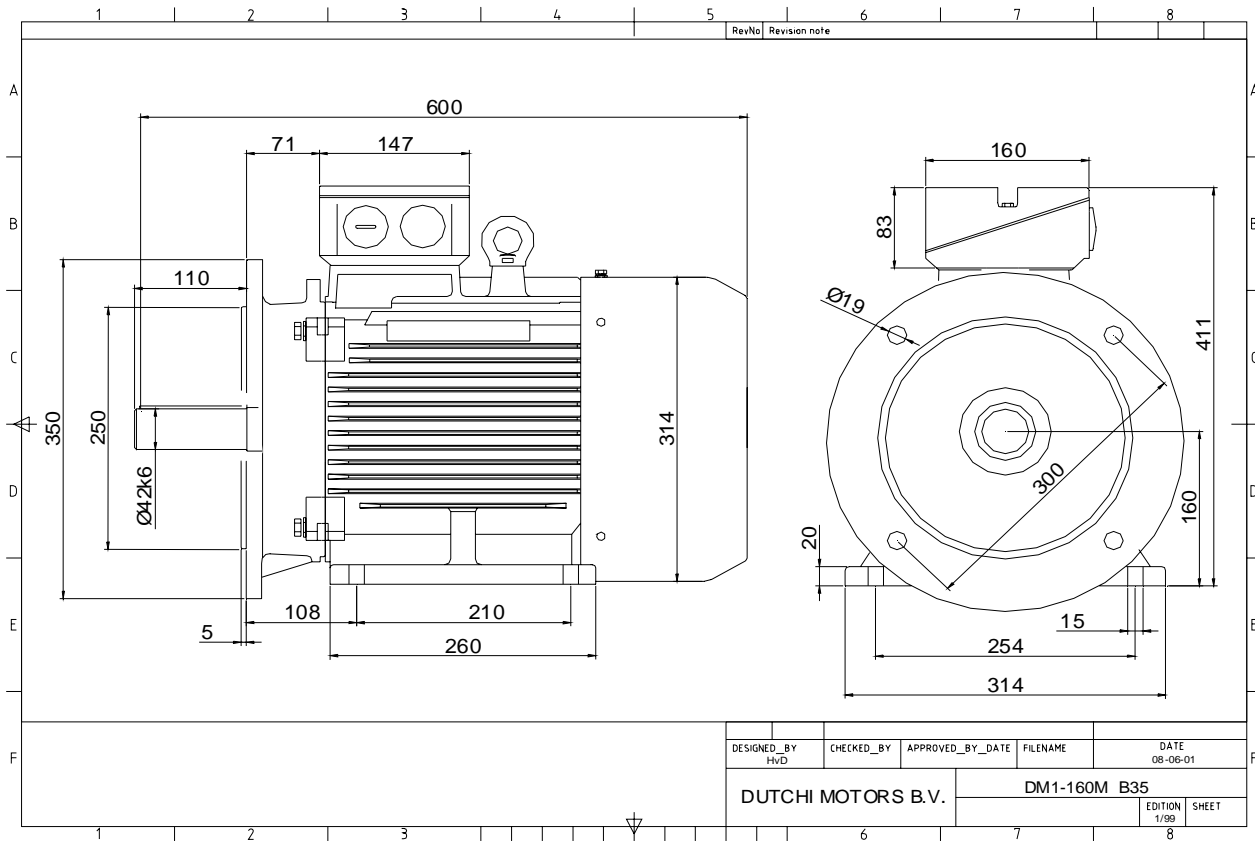

Specification **IEC 60034-1**
 Manufacturer **Dutchi Motors B.V.**
 Motor type **DM1- 160 M2**
 Rated power **11,00 kW S1** duty
 Speed **2935** r.p.m
 Voltage **400 / 690** V
 Frequency **50** Hz
 Connection **Δ / Y**
 Amps full load **20,18 / 11,65** A
 Amps no-load(400V) **6,21** A
 Enclosure **IP 55**
 Insulation Class **F (temp. rise B (80 K))**

Max. coolant temp. **40°C**
 Max. altitude **1.000** mtr, above sea level
 Comment **3 x PTC 150°C**
 Cable entries **2 x M40x1,5 + 1 x M20x1,5 (ptc)**

Feature **Cast-iron motor**
 Weight **107** kg
 Catalog no. **11532A11D**
 Warranty **12~18 months**

Efficiency class **EFF 2**
 Load data 100% 75% 50% 25%
 Efficiency **89,2 89,4 87,8 81,4** %
 Power factor **0,88 0,86 0,78 0,60**

Sound pressure level (1m) **78,5** dB(A)
 Resistance R20 (open) **0,856** Ω
 Resistance R20 **Δ 0,571** Ω

Full load torque **35,79** Nm
 DOL Starting torque vs FL torque **2,11**
 DOL Pull up torque vs FL torque **1,54**
 DOL Pull out torque vs FL torque **3,02**
 Star-Delta Starting torque vs FL torque **0,66**
 Star-Delta Pull up torque vs FL torque **0,48**
 Star-Delta Pull out torque vs FL torque **0,94**
 DOL Starting current vs FL current **6,58**
 Star Delta Starting current vs FL current **2,06**
 Rotor Inertia **0,0370** kgm²

Bearing DE **6309 - ZZ C3**
 Bearing NDE **6309 - ZZ C3**

WI	Change	date	sign.
Dutchi Motors B.V. P.O. Box 5390 NL-6802 EJ ARNHEM Tel : +31-(0)26 - 3541 600 Fax : +31-(0)26 - 3541 650		Discription Drawing made by : 27-04-04	date sign. HVD
dutchi.motors@dutchi.nl www.dutchi.com			

Power is our commodity, the world is our market !

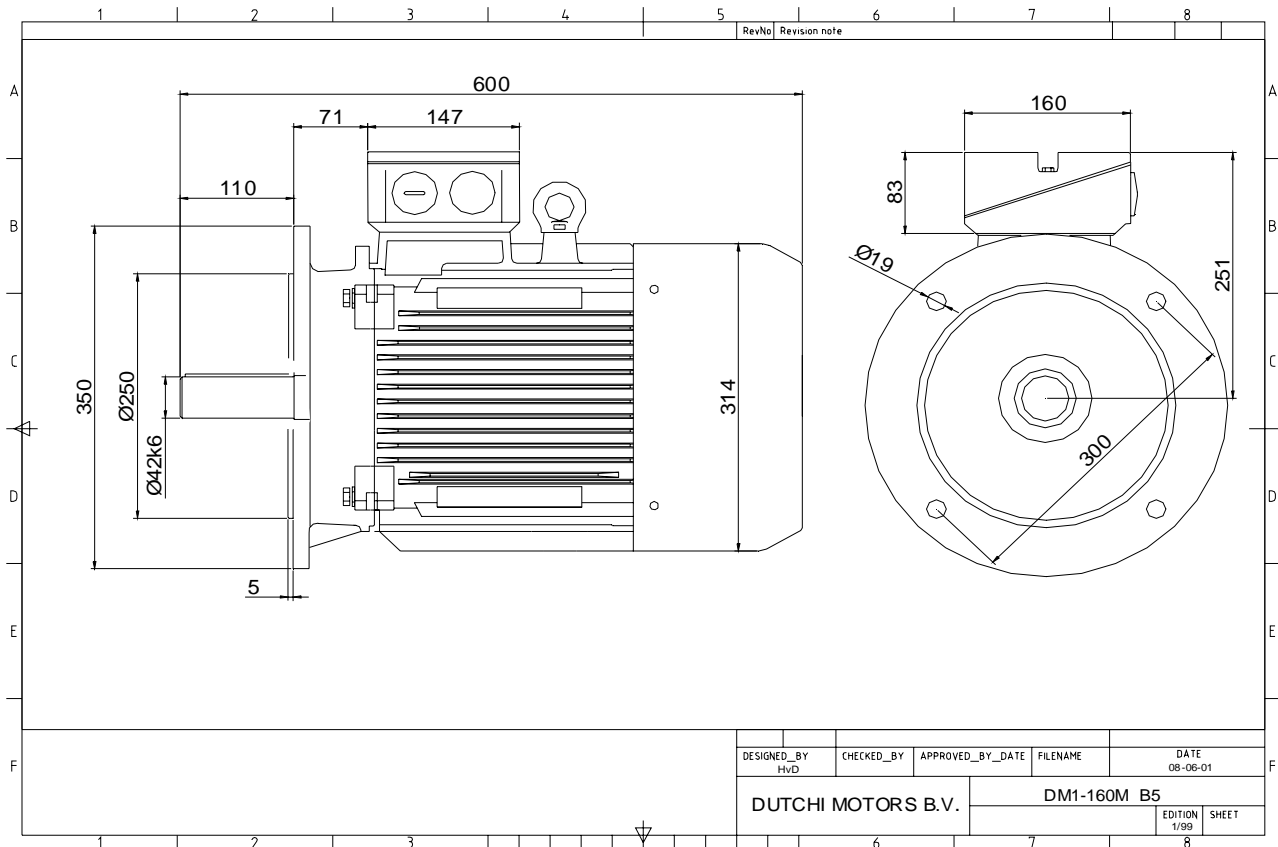

Specification **IEC 60034-1**
 Manufacturer **Dutchi Motors B.V.**
 Motor type **DM1- 160 M2**
 Rated power **11,00 kW S1** duty
 Speed **2935** r.p.m
 Voltage **400 / 690** V
 Frequency **50** Hz
 Connection **Δ / Y**
 Amps full load **20,18 / 11,65** A
 Amps no-load(400V) **6,21** A
 Enclosure **IP 55**
 Insulation Class **F (temp. rise B (80 K))**

Max. coolant temp. **40°C**
 Max. altitude **1.000** mtr, above sea level
 Comment **3 x PTC 150°C**
 Cable entries **2 x M40x1,5 + 1 x M20x1,5 (ptc)**

Feature **Cast-iron motor**
 Weight **107** kg
 Catalog no. **11232A11D**
 Warranty **12~18 months**

Efficiency class **EFF 2**
 Load data 100% 75% 50% 25%
 Efficiency **89,2 89,4 87,8 81,4** %
 Power factor **0,88 0,86 0,78 0,60**

Sound pressure level (1m) **78,5** dB(A)
 Resistance R20 (open) **0,856** Ω
 Resistance R20 **Δ 0,571** Ω

Full load torque **35,79** Nm
 DOL Starting torque vs FL torque **2,11**
 DOL Pull up torque vs FL torque **1,54**
 DOL Pull out torque vs FL torque **3,02**
 Star-Delta Starting torque vs FL torque **0,66**
 Star-Delta Pull up torque vs FL torque **0,48**
 Star-Delta Pull out torque vs FL torque **0,94**
 DOL Starting current vs FL current **6,58**
 Star Delta Starting current vs FL current **2,06**
 Rotor Inertia **0,0370** kgm2

Bearing DE **6309 - ZZ C3**
 Bearing NDE **6309 - ZZ C3**

WI	Change	date	sign.
Dutchi Motors B.V. P.O. Box 5390 NL-6802 EJ ARNHEM Tel : +31-(0)26 - 3541 600 Fax : +31-(0)26 - 3541 650		Discription Drawing made by :	date sign. HvD
dutchi.motors@dutchi.nl www.dutchi.com		27-04-04	

Power is our commodity, the world is our market !

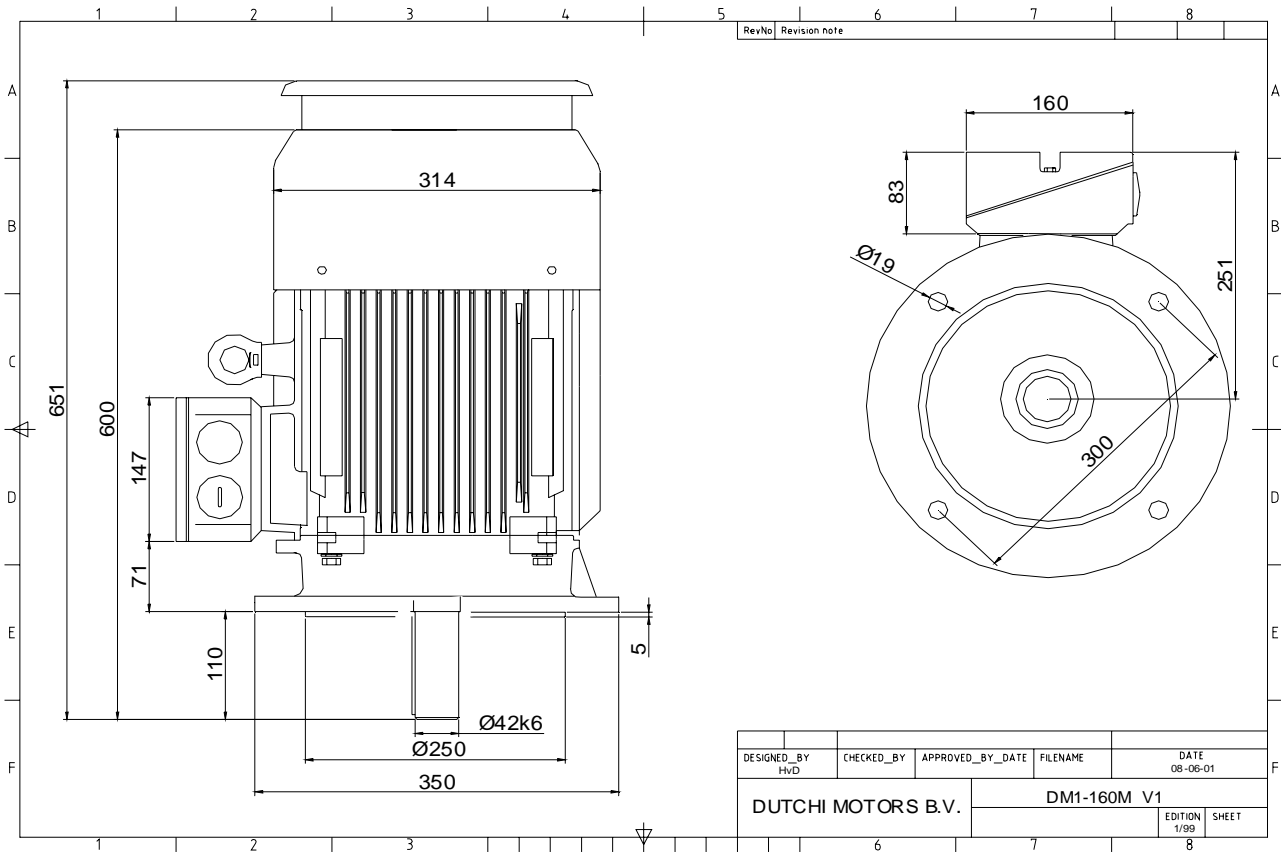

Specification **IEC 60034-1**
 Manufacturer **Dutchi Motors B.V.**
 Motor type **DM1- 160 M2**
 Rated power **11,00 kW S1** duty
 Speed **2935** r.p.m
 Voltage **400 / 690** V
 Frequency **50** Hz
 Connection **Δ / Y**
 Amps full load **20,18 / 11,65** A
 Amps no-load(400V) **6,21** A
 Enclosure **IP 55**
 Insulation Class **F (temp. rise B (80 K))**

Max. coolant temp. **40°C**
 Max. altitude **1.000** mtr, above sea level
 Comment **3 x PTC 150°C**
 Cable entries **2 x M40x1,5 + 1 x M20x1,5 (ptc)**

Feature **Cast-iron motor**
 Weight **107** kg
 Catalog no. **11032A11D**
 Warranty **12~18 months**

Efficiency class **EFF 2**
 Load data 100% 75% 50% 25%
 Efficiency **89,2 89,4 87,8 81,4** %
 Power factor **0,88 0,86 0,78 0,60**

Sound pressure level (1m) **78,5** dB(A)
 Resistance R20 (open) **0,856** Ω
 Resistance R20 **Δ 0,571** Ω

Full load torque **35,79** Nm
 DOL Starting torque vs FL torque **2,11**
 DOL Pull up torque vs FL torque **1,54**
 DOL Pull out torque vs FL torque **3,02**
 Star-Delta Starting torque vs FL torque **0,66**
 Star-Delta Pull up torque vs FL torque **0,48**
 Star-Delta Pull out torque vs FL torque **0,94**
 DOL Starting current vs FL current **6,58**
 Star Delta Starting current vs FL current **2,06**
 Rotor Inertia **0,0370** kgm²

Bearing DE **6309 - ZZ C3**
 Bearing NDE **6309 - ZZ C3**

WI	Change	date	sign.
Dutchi Motors B.V.		Description	date
P.O. Box 5390		Drawing made by :	27-04-04
NL-6802 EJ ARNHEM			
Tel : +31-(0)26 - 3541 600		dutchi.motors@dutchi.nl	
Fax : +31-(0)26 - 3541 650		www.dutchi.com	