

Power is our commodity, the world is our market !

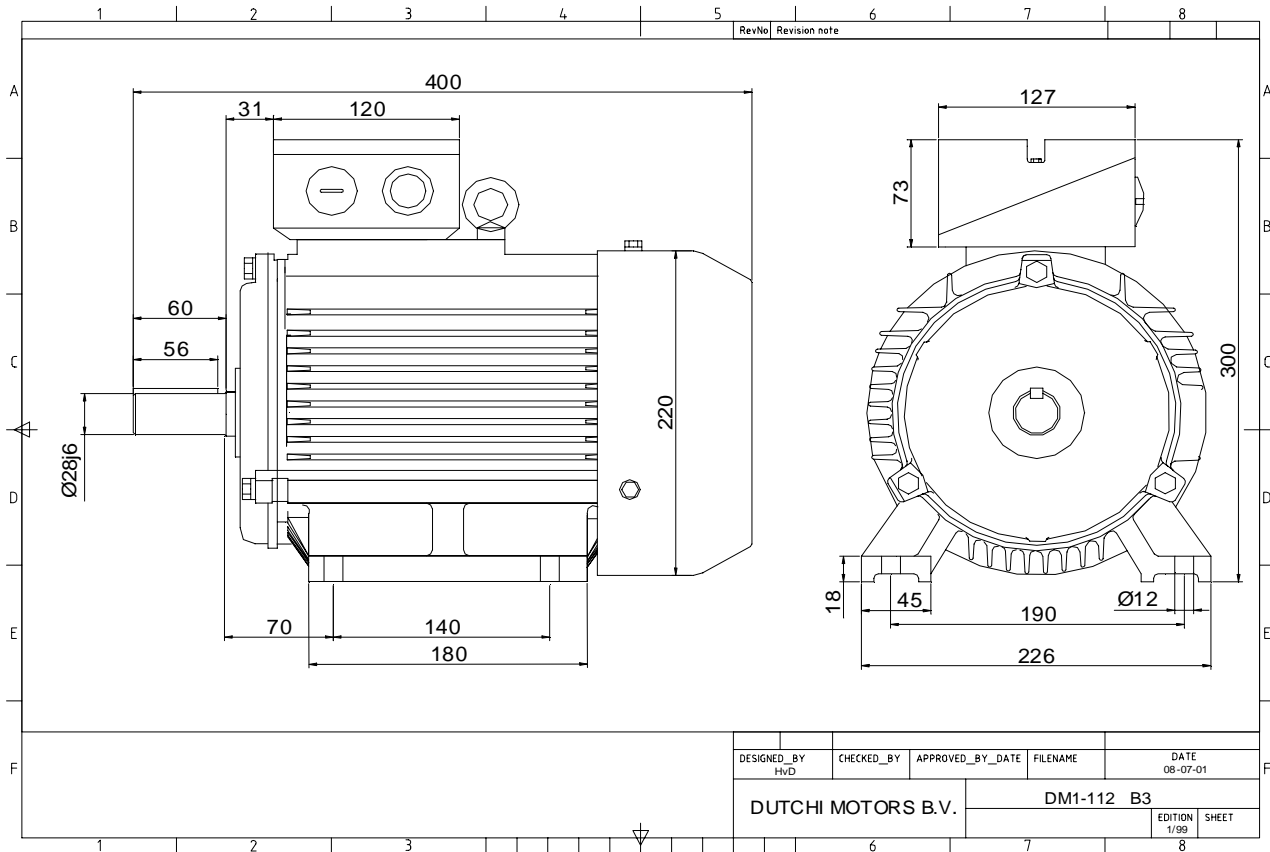

DESIGNED_BY HvD	CHECKED_BY	APPROVED_BY_DATE	FILENAME	DATE 08-07-01
DUTCHI MOTORS B.V.			DM1-112 B3	EDITION 1/99
				SHEET

Specification	IEC 60034-1
Manufacturer	Dutchi Motors B.V.
Motor type	DM1-HE 112M2
Rated power	4,00 kW S1 duty
Speed	2890 r.p.m
Voltage	400 / 690 V
Frequency	50 Hz
Connection	Δ / Y
Amps full load	7,11 / 4,10 A
Amps no-load(400V)	1,80 A
Enclosure	IP 55
Insulation Class	F (temp. rise B (80 K))
Max. coolant temp.	40°C
Max. altitude	1.000 mtr, above sea level
Comment	3 x PTC 150°C
Cable entries	2 x M32x1,5 + 1 x M20x1,5 (ptc)
Feature	Cast-iron motor
Weight	kg
Catalog no.	11132400DH
Warranty	12~18 months

Efficiency class	EFF 1
Load data	100% 75% 50% 25%
Efficiency	88,0 89,1 89,0 84,7 %
Power factor	0,92 0,90 0,86 0,71
Sound pressure level (1m)	61,8 dB(A)
Resistance R20 (open)	3,61 Ω
Resistance R20	Δ 2,40 Ω
Full load torque	13,22 Nm
DOL Starting torque vs FL torque	2,04
DOL Pull up torque vs FL torque	1,53
DOL Pull out torque vs FL torque	3,14
Star-Delta Starting torque vs FL torque	0,64
Star-Delta Pull up torque vs FL torque	0,48
Star-Delta Pull out torque vs FL torque	0,98
DOL Starting current vs FL current	7,11
Star Delta Starting current vs FL current	2,22
Rotor Inertia	kgm ²
Bearing DE	6306 - ZZ C3
Bearing NDE	6306 - ZZ C3

WI	Change	date	sign.
Dutchi Motors B.V.		Description	date
P.O. Box 5390		Drawing made by :	19-04-04
NL-6802 EJ ARNHEM			
Tel : +31-(0)26 - 3541 600		dutchi.motors@dutchi.nl	
Fax : +31-(0)26 - 3541 650		www.dutchi.com	

Power is our commodity, the world is our market !

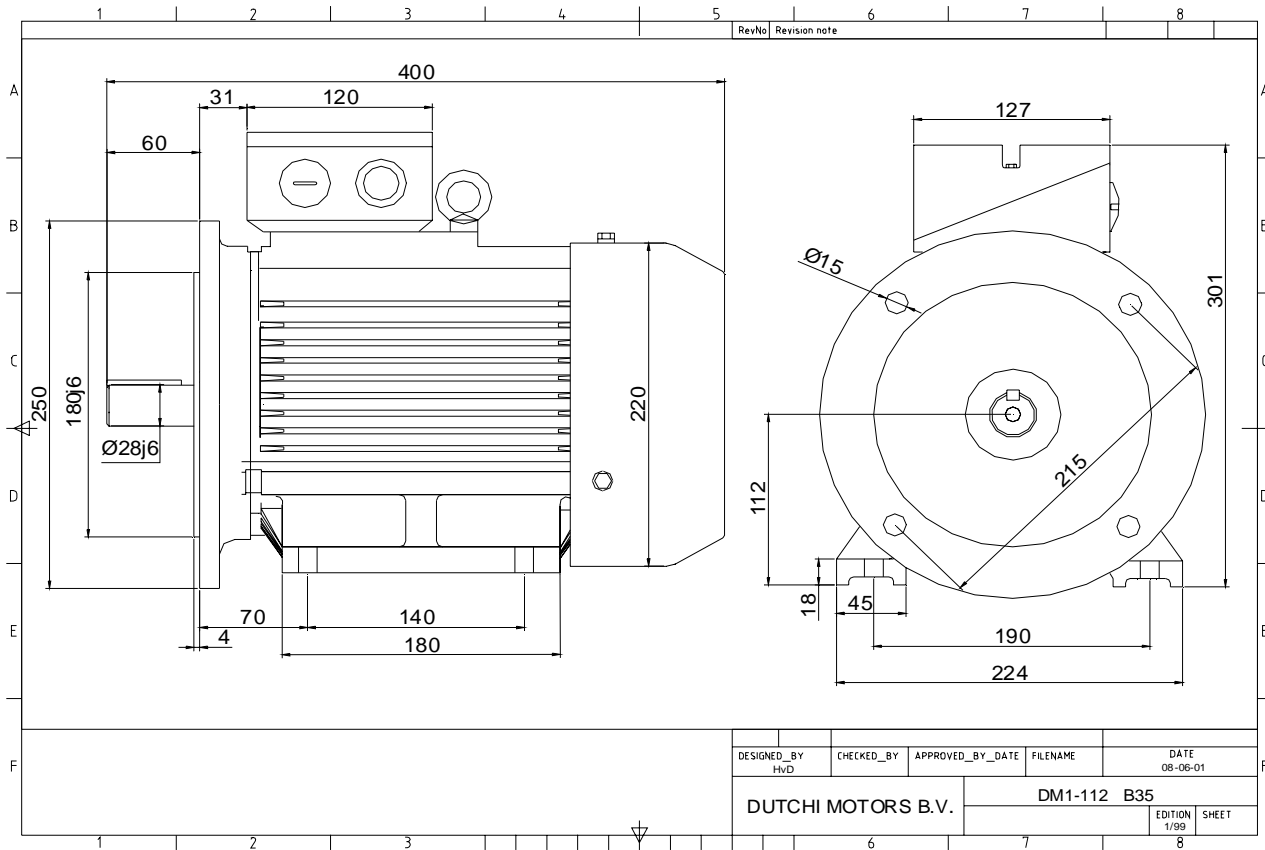

Specification **IEC 60034-1**
 Manufacturer **Dutchi Motors B.V.**
 Motor type **DM1-HE 112M2**
 Rated power **4,00** kW **S1** duty
 Speed **2890** r.p.m
 Voltage **400** / **690** V
 Frequency **50** Hz
 Connection **Δ** / **Y**
 Amps full load **7,11** / **4,10** A
 Amps no-load(400V) **1,80** A
 Enclosure **IP 55**
 Insulation Class **F (temp. rise B (80 K))**

Max. coolant temp. **40°C**
 Max. altitude **1.000** mtr, above sea level
 Comment **3 x PTC 150°C**
 Cable entries **2 x M32x1,5 + 1 x M20x1,5 (ptc)**

Feature **Cast-iron motor**
 Weight kg
 Catalog no. **11532400DH**
 Warranty **12~18 months**

Efficiency class **EFF 1**
 Load data 100% 75% 50% 25%
 Efficiency **88,0 89,1 89,0 84,7** %
 Power factor **0,92 0,90 0,86 0,71**

Sound pressure level (1m) **61,8** dB(A)
 Resistance R20 (open) **3,61** Ω
 Resistance R20 **Δ 2,40** Ω

Full load torque **13,22** Nm
 DOL Starting torque vs FL torque **2,04**
 DOL Pull up torque vs FL torque **1,53**
 DOL Pull out torque vs FL torque **3,14**
 Star-Delta Starting torque vs FL torque **0,64**
 Star-Delta Pull up torque vs FL torque **0,48**
 Star-Delta Pull out torque vs FL torque **0,98**
 DOL Starting current vs FL current **7,11**
 Star Delta Starting current vs FL current **2,22**

Rotor Inertia kgm2

Bearing DE **6306 - ZZ C3**
 Bearing NDE **6306 - ZZ C3**

WI	Change	date	sign.
Dutchi Motors B.V.		Description	date
P.O. Box 5390		Drawing made by :	19-04-04
NL-6802 EJ ARNHEM			
Tel : +31-(0)26 - 3541 600		dutchi.motors@dutchi.nl	
Fax : +31-(0)26 - 3541 650		www.dutchi.com	

Power is our commodity, the world is our market !

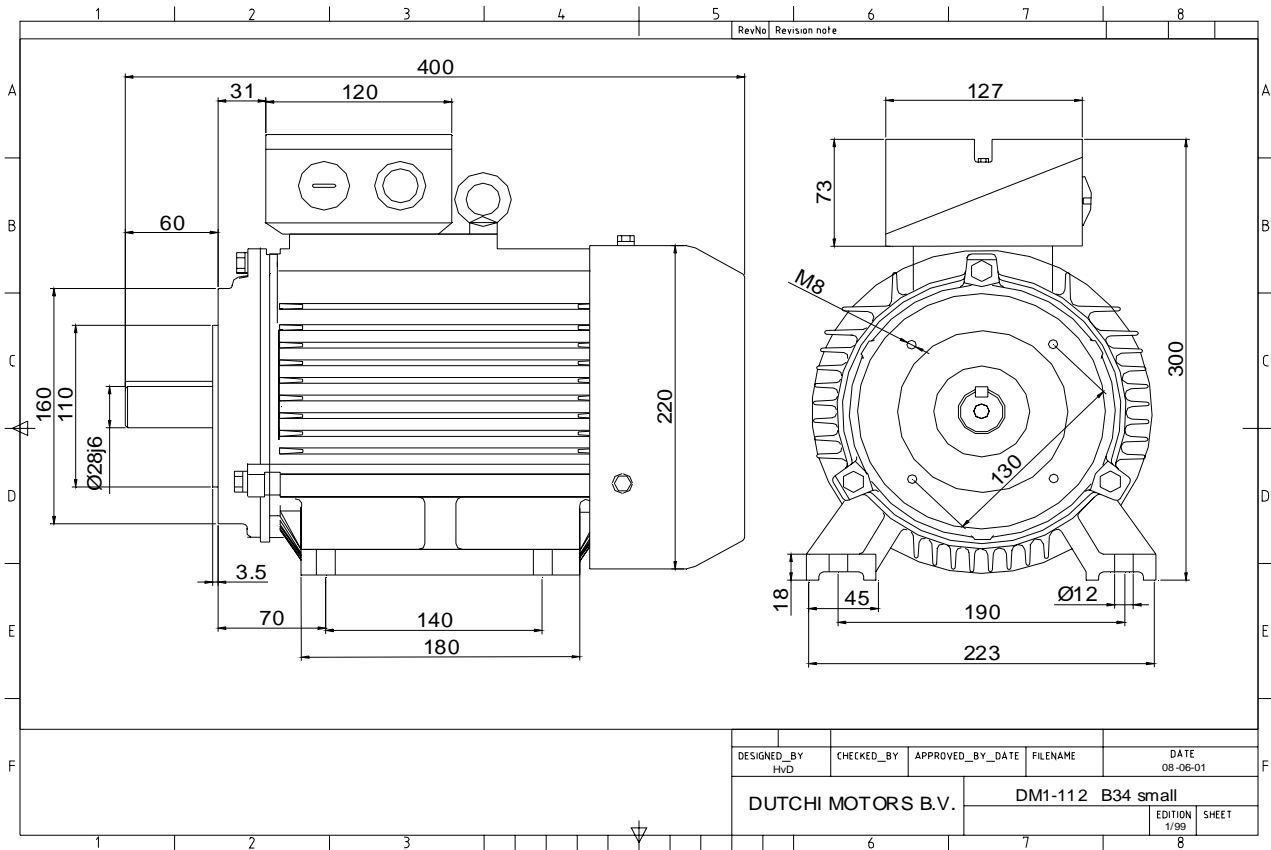

Specification **IEC 60034-1**
 Manufacturer **Dutchi Motors B.V.**
 Motor type **DM1-HE 112M2**
 Rated power **4,00** kW **S1** duty
 Speed **2890** r.p.m
 Voltage **400** / **690** V
 Frequency **50** Hz
 Connection **Δ** / **Y**
 Amps full load **7,11** / **4,10** A
 Amps no-load(400V) **1,80** A
 Enclosure **IP 55**
 Insulation Class **F (temp. rise B (80 K))**

Max. coolant temp. **40°C**
 Max. altitude **1.000** mtr, above sea level
 Comment **3 x PTC 150°C**
 Cable entries **2 x M32x1,5 + 1 x M20x1,5 (ptc)**

Feature **Cast-iron motor**
 Weight **kg**
 Catalog no. **11632400DH**
 Warranty **12~18 months**

Efficiency class **EFF 1**
 Load data 100% 75% 50% 25%
 Efficiency **88,0 89,1 89,0 84,7** %
 Power factor **0,92 0,90 0,86 0,71**

Sound pressure level (1m) **61,8** dB(A)
 Resistance R20 (open) **3,61** Ω
 Resistance R20 **Δ 2,40** Ω

Full load torque **13,22** Nm
 DOL Starting torque vs FL torque **2,04**
 DOL Pull up torque vs FL torque **1,53**
 DOL Pull out torque vs FL torque **3,14**
 Star-Delta Starting torque vs FL torque **0,64**
 Star-Delta Pull up torque vs FL torque **0,48**
 Star-Delta Pull out torque vs FL torque **0,98**
 DOL Starting current vs FL current **7,11**
 Star Delta Starting current vs FL current **2,22**

Rotor Inertia **kgm2**

Bearing DE **6306 - ZZ C3**
 Bearing NDE **6306 - ZZ C3**

WI	Change	date	sign.
Dutchi Motors B.V. P.O. Box 5390 NL-6802 EJ ARNHEM Tel : +31-(0)26 - 3541 600 Fax : +31-(0)26 - 3541 650		Description	date
		Drawing made by :	19-04-04
		dutchi.motors@dutchi.nl www.dutchi.com	

Power is our commodity, the world is our market !

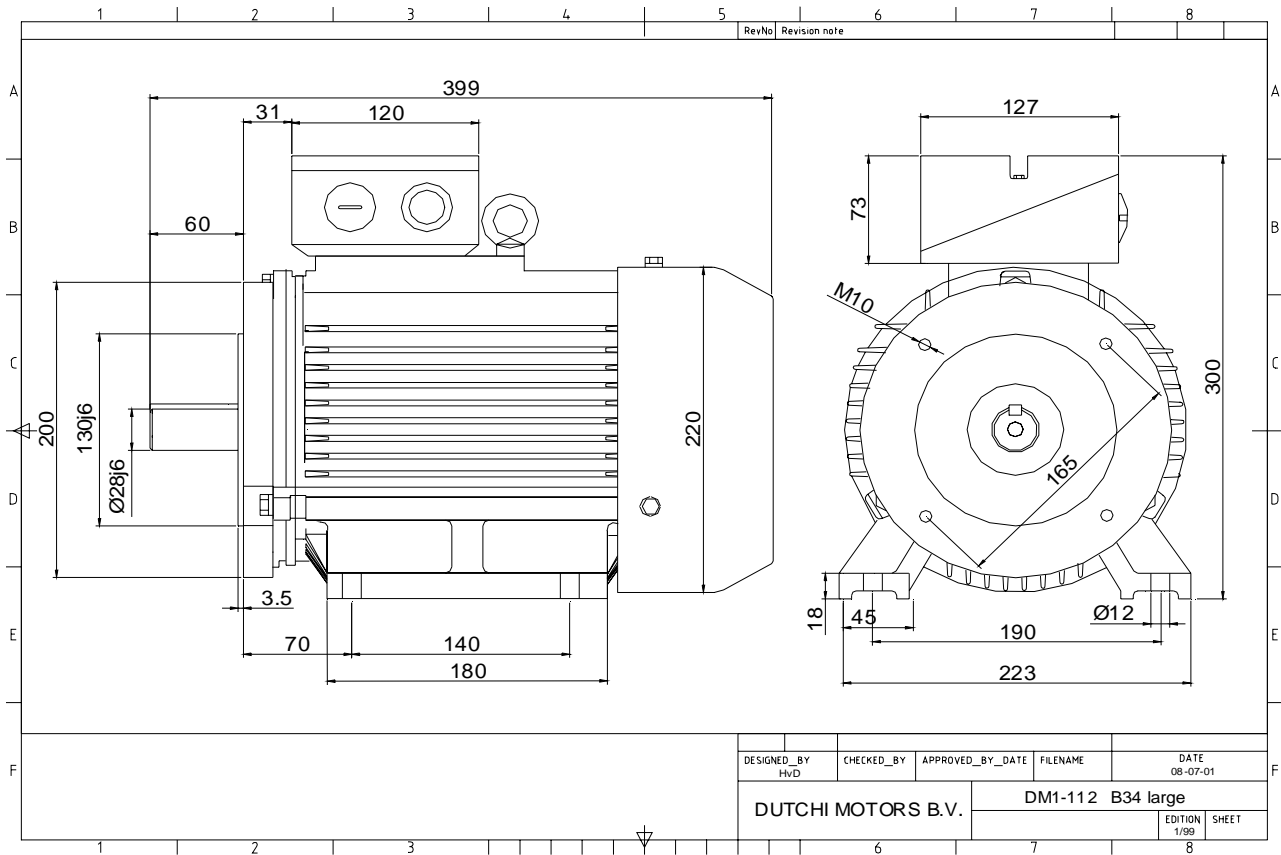

Specification **IEC 60034-1**
 Manufacturer **Dutchi Motors B.V.**
 Motor type **DM1-HE 112M2**
 Rated power **4,00** kW **S1** duty
 Speed **2890** r.p.m
 Voltage **400** / **690** V
 Frequency **50** Hz
 Connection **Δ** / **Y**
 Amps full load **7,11** / **4,10** A
 Amps no-load(400V) **1,80** A
 Enclosure **IP 55**
 Insulation Class **F (temp. rise B (80 K))**

Max. coolant temp. **40°C**
 Max. altitude **1.000** mtr, above sea level
 Comment **3 x PTC 150°C**
 Cable entries **2 x M32x1,5 + 1 x M20x1,5 (ptc)**

Feature **Cast-iron motor**
 Weight **kg**
 Catalog no. **11732400DH**
 Warranty **12~18 months**

Efficiency class **EFF 1**
 Load data 100% 75% 50% 25%
 Efficiency **88,0 89,1 89,0 84,7** %
 Power factor **0,92 0,90 0,86 0,71**

Sound pressure level (1m) **61,8** dB(A)
 Resistance R20 (open) **3,61** Ω
 Resistance R20 **Δ 2,40** Ω

Full load torque **13,22** Nm
 DOL Starting torque vs FL torque **2,04**
 DOL Pull up torque vs FL torque **1,53**
 DOL Pull out torque vs FL torque **3,14**
 Star-Delta Starting torque vs FL torque **0,64**
 Star-Delta Pull up torque vs FL torque **0,48**
 Star-Delta Pull out torque vs FL torque **0,98**
 DOL Starting current vs FL current **7,11**
 Star Delta Starting current vs FL current **2,22**

Rotor Inertia **kgm2**

Bearing DE **6306 - ZZ C3**
 Bearing NDE **6306 - ZZ C3**

WI	Change	date	sign.
Dutchi Motors B.V. P.O. Box 5390 NL-6802 EJ ARNHEM Tel : +31-(0)26 - 3541 600 Fax : +31-(0)26 - 3541 650		Description	date
		Drawing made by :	19-04-04
		dutchi.motors@dutchi.nl www.dutchi.com	

Power is our commodity, the world is our market !

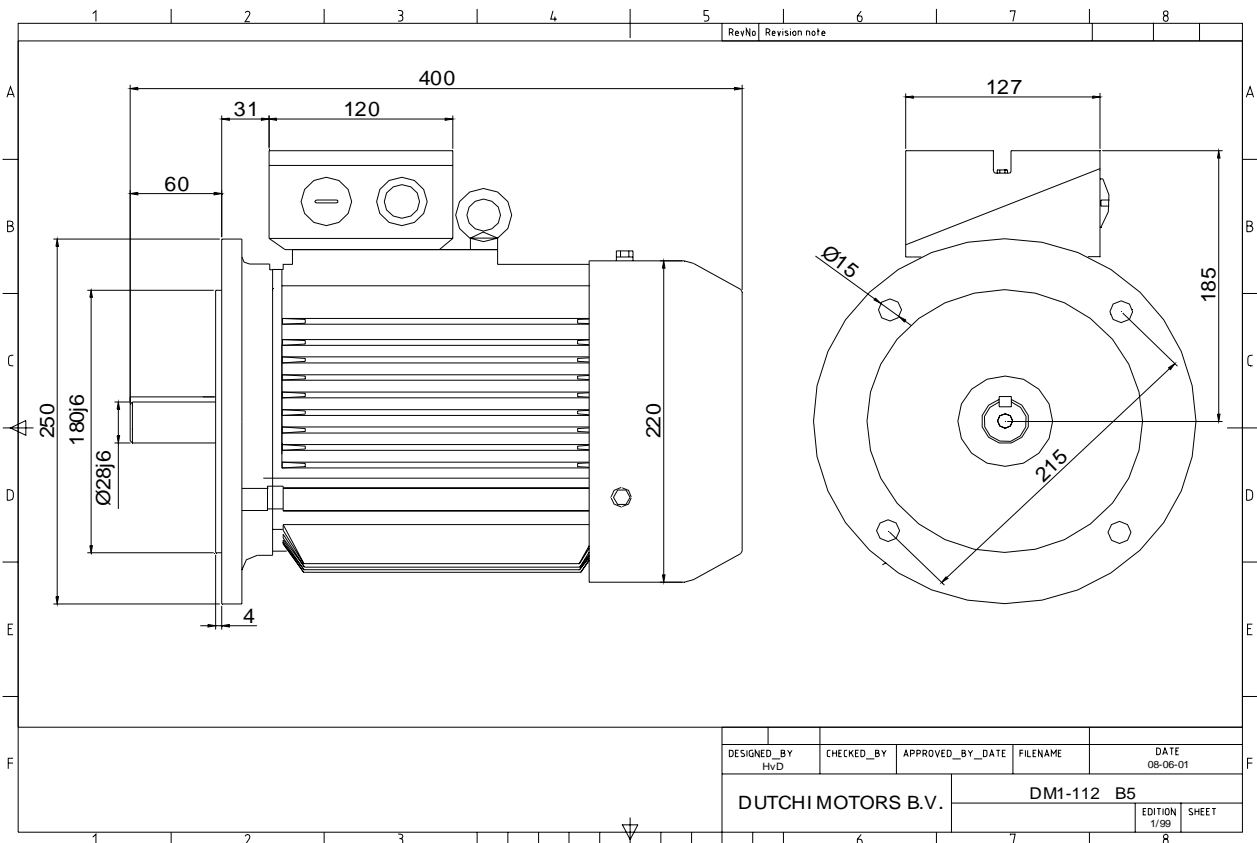

Specification **IEC 60034-1**
 Manufacturer **Dutchi Motors B.V.**
 Motor type **DM1-HE 112M2**
 Rated power **4,00** kW **S1** duty
 Speed **2890** r.p.m
 Voltage **400** / **690** V
 Frequency **50** Hz
 Connection **Δ** / **Y**
 Amps full load **7,11** / **4,10** A
 Amps no-load(400V) **1,80** A
 Enclosure **IP 55**
 Insulation Class **F (temp. rise B (80 K))**

Max. coolant temp. **40°C**
 Max. altitude **1.000** mtr, above sea level
 Comment **3 x PTC 150°C**
 Cable entries **2 x M32x1,5 + 1 x M20x1,5 (ptc)**

Feature **Cast-iron motor**
 Weight **kg**
 Catalog no. **11232400DH**
 Warranty **12~18 months**

Efficiency class **EFF 1**
 Load data 100% 75% 50% 25%
 Efficiency **88,0 89,1 89,0 84,7** %
 Power factor **0,92 0,90 0,86 0,71**

Sound pressure level (1m) **61,8** dB(A)
 Resistance R20 (open) **3,61** Ω
 Resistance R20 **Δ 2,40** Ω

Full load torque **13,22** Nm
 DOL Starting torque vs FL torque **2,04**
 DOL Pull up torque vs FL torque **1,53**
 DOL Pull out torque vs FL torque **3,14**
 Star-Delta Starting torque vs FL torque **0,64**
 Star-Delta Pull up torque vs FL torque **0,48**
 Star-Delta Pull out torque vs FL torque **0,98**
 DOL Starting current vs FL current **7,11**
 Star Delta Starting current vs FL current **2,22**

Rotor Inertia **kgm2**

Bearing DE **6306 - ZZ C3**
 Bearing NDE **6306 - ZZ C3**

WI	Change	date	sign.
Dutchi Motors B.V.		Description	date
P.O. Box 5390		Drawing made by :	19-04-04
NL-6802 EJ ARNHEM			
Tel : +31-(0)26 - 3541 600		dutchi.motors@dutchi.nl	
Fax : +31-(0)26 - 3541 650		www.dutchi.com	

Power is our commodity, the world is our market !

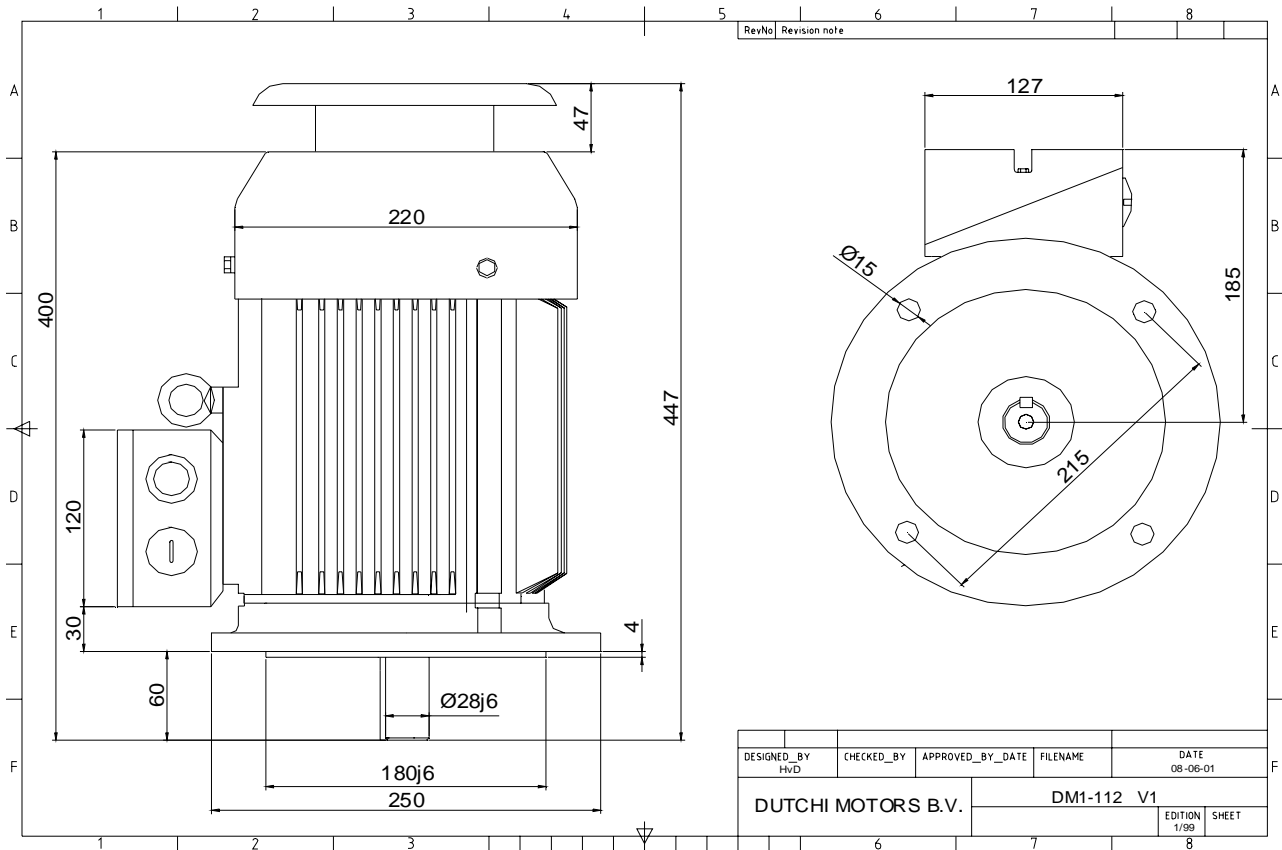

Specification **IEC 60034-1**
 Manufacturer **Dutchi Motors B.V.**
 Motor type **DM1-HE 112M2**
 Rated power **4,00** kW **S1** duty
 Speed **2890** r.p.m
 Voltage **400** / **690** V
 Frequency **50** Hz
 Connection **Δ** / **Y**
 Amps full load **7,11** / **4,10** A
 Amps no-load(400V) **1,80** A
 Enclosure **IP 55**
 Insulation Class **F (temp. rise B (80 K))**

Max. coolant temp. **40°C**
 Max. altitude **1.000** mtr, above sea level
 Comment **3 x PTC 150°C**
 Cable entries **2 x M32x1,5 + 1 x M20x1,5 (ptc)**

Feature **Cast-iron motor**
 Weight **kg**
 Catalog no. **11032400DH**
 Warranty **12~18 months**

Efficiency class **EFF 1**
 Load data 100% 75% 50% 25%
 Efficiency **88,0 89,1 89,0 84,7** %
 Power factor **0,92 0,90 0,86 0,71**

Sound pressure level (1m) **61,8** dB(A)
 Resistance R20 (open) **3,61** Ω
 Resistance R20 **Δ 2,40** Ω

Full load torque **13,22** Nm
 DOL Starting torque vs FL torque **2,04**
 DOL Pull up torque vs FL torque **1,53**
 DOL Pull out torque vs FL torque **3,14**
 Star-Delta Starting torque vs FL torque **0,64**
 Star-Delta Pull up torque vs FL torque **0,48**
 Star-Delta Pull out torque vs FL torque **0,98**
 DOL Starting current vs FL current **7,11**
 Star Delta Starting current vs FL current **2,22**

Rotor Inertia **kgm2**

Bearing DE **6306 - ZZ C3**
 Bearing NDE **6306 - ZZ C3**

WI	Change	date	sign.
Dutchi Motors B.V.		Discription	date
P.O. Box 5390		Drawing made by :	19-04-04
NL-6802 EJ ARNHEM			
Tel : +31-(0)26 - 3541 600		dutchi.motors@dutchi.nl	
Fax : +31-(0)26 - 3541 650		www.dutchi.com	

Power is our commodity, the world is our market !

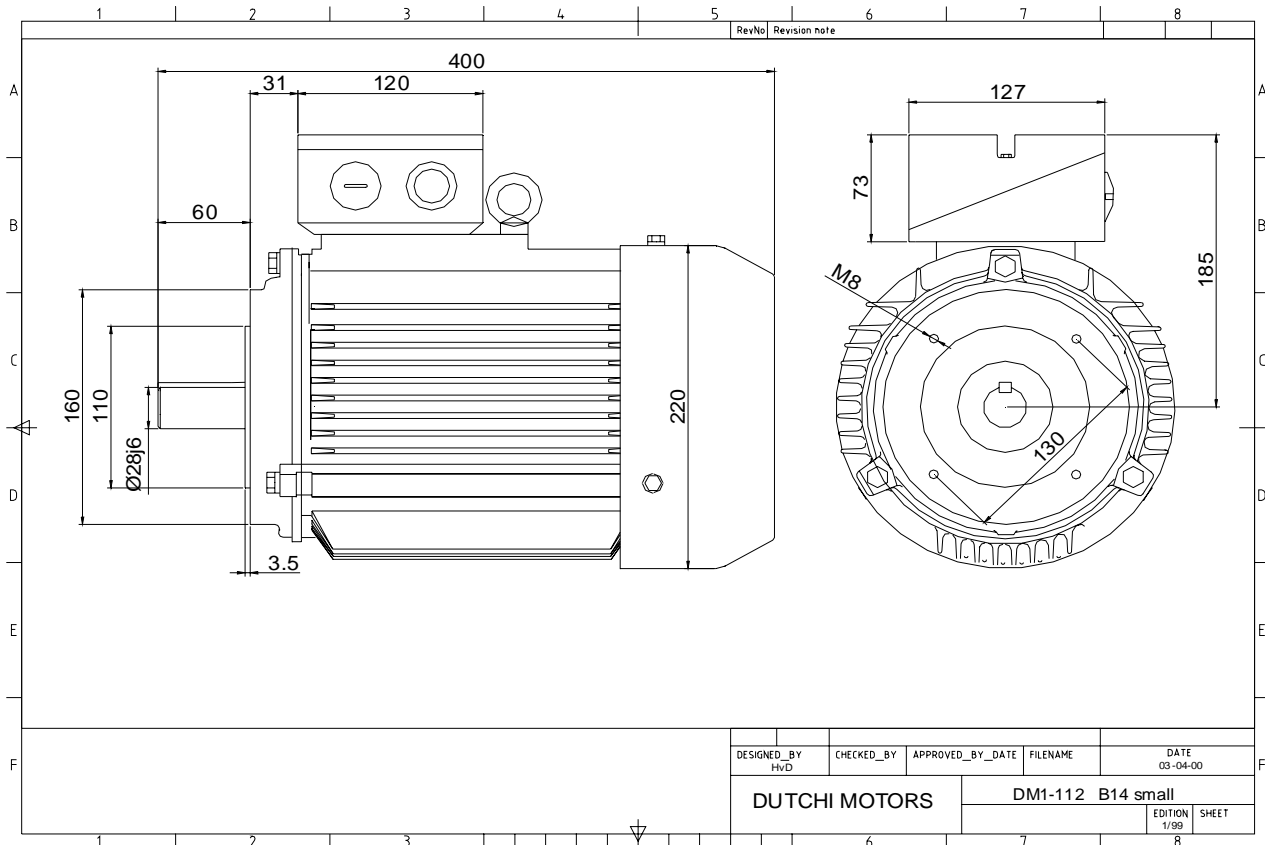

Specification **IEC 60034-1**
 Manufacturer **Dutchi Motors B.V.**
 Motor type **DM1-HE 112M2**
 Rated power **4,00** kW **S1** duty
 Speed **2890** r.p.m
 Voltage **400** / **690** V
 Frequency **50** Hz
 Connection **Δ** / **Y**
 Amps full load **7,11** / **4,10** A
 Amps no-load(400V) **1,80** A
 Enclosure **IP 55**
 Insulation Class **F (temp. rise B (80 K))**

Max. coolant temp. **40°C**
 Max. altitude **1.000** mtr, above sea level
 Comment **3 x PTC 150°C**
 Cable entries **2 x M32x1,5 + 1 x M20x1,5 (ptc)**

Feature **Cast-iron motor**
 Weight **kg**
 Catalog no. **11332400DH**
 Warranty **12~18 months**

Efficiency class **EFF 1**
 Load data 100% 75% 50% 25%
 Efficiency **88,0 89,1 89,0 84,7** %
 Power factor **0,92 0,90 0,86 0,71**

Sound pressure level (1m) **61,8** dB(A)
 Resistance R20 (open) **3,61** Ω
 Resistance R20 **Δ 2,40** Ω

Full load torque **13,22** Nm
 DOL Starting torque vs FL torque **2,04**
 DOL Pull up torque vs FL torque **1,53**
 DOL Pull out torque vs FL torque **3,14**
 Star-Delta Starting torque vs FL torque **0,64**
 Star-Delta Pull up torque vs FL torque **0,48**
 Star-Delta Pull out torque vs FL torque **0,98**
 DOL Starting current vs FL current **7,11**
 Star Delta Starting current vs FL current **2,22**

Rotor Inertia **kgm2**

Bearing DE **6306 - ZZ C3**
 Bearing NDE **6306 - ZZ C3**

WI	Change	date	sign.
Dutchi Motors B.V. P.O. Box 5390 NL-6802 EJ ARNHEM Tel : +31-(0)26 - 3541 600 Fax : +31-(0)26 - 3541 650		Description	date
		Drawing made by :	19-04-04
dutchi.motors@dutchi.nl www.dutchi.com		sign.	HvD

Power is our commodity, the world is our market !

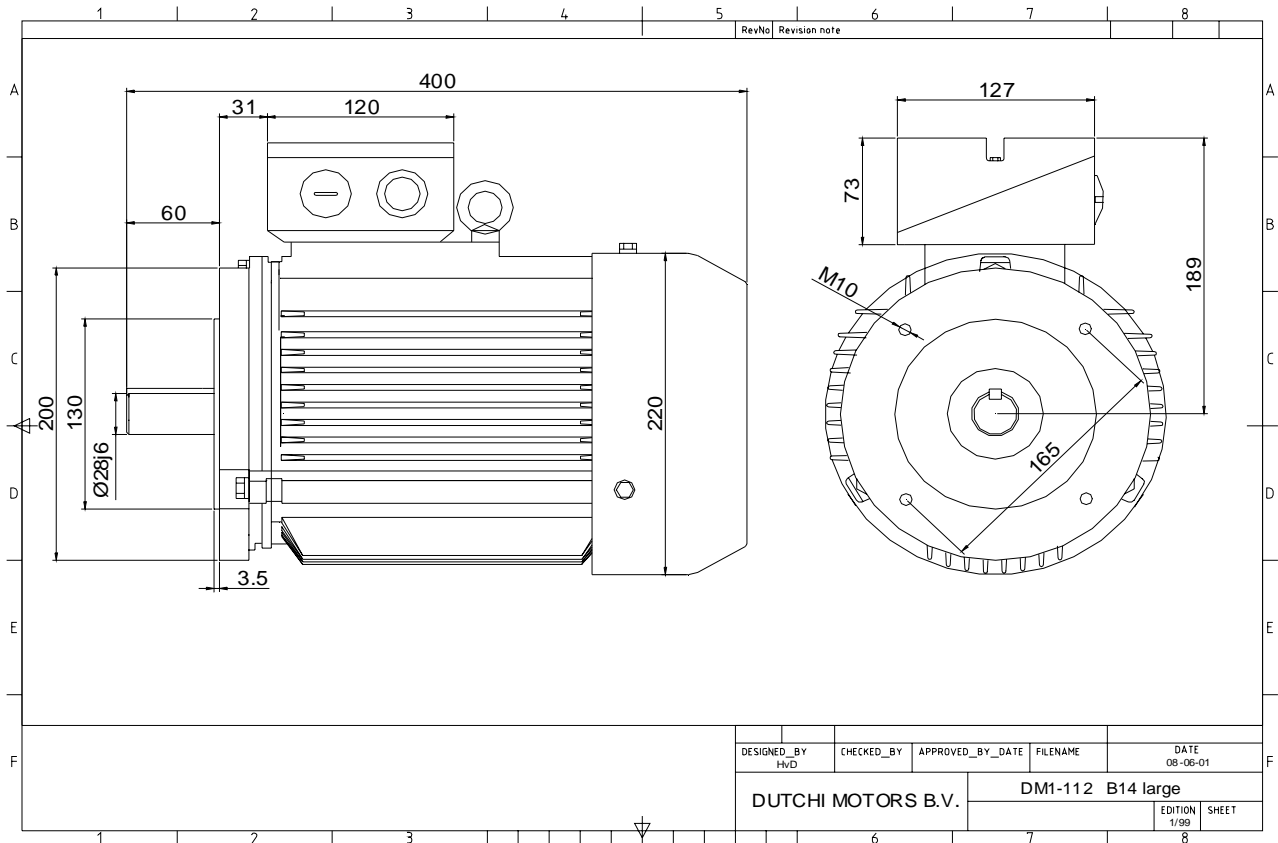

Specification **IEC 60034-1**
 Manufacturer **Dutchi Motors B.V.**
 Motor type **DM1-HE 112M2**
 Rated power **4,00** kW **S1** duty
 Speed **2890** r.p.m
 Voltage **400** / **690** V
 Frequency **50** Hz
 Connection **Δ** / **Y**
 Amps full load **7,11** / **4,10** A
 Amps no-load(400V) **1,80** A
 Enclosure **IP 55**
 Insulation Class **F (temp. rise B (80 K))**

Max. coolant temp. **40°C**
 Max. altitude **1.000** mtr, above sea level
 Comment **3 x PTC 150°C**
 Cable entries **2 x M32x1,5 + 1 x M20x1,5 (ptc)**

Feature **Cast-iron motor**
 Weight **kg**
 Catalog no. **11432400DH**
 Warranty **12~18 months**

Efficiency class **EFF 1**
 Load data 100% 75% 50% 25%
 Efficiency **88,0 89,1 89,0 84,7** %
 Power factor **0,92 0,90 0,86 0,71**

Sound pressure level (1m) **61,8** dB(A)
 Resistance R20 (open) **3,61** Ω
 Resistance R20 **Δ 2,40** Ω

Full load torque **13,22** Nm
 DOL Starting torque vs FL torque **2,04**
 DOL Pull up torque vs FL torque **1,53**
 DOL Pull out torque vs FL torque **3,14**
 Star-Delta Starting torque vs FL torque **0,64**
 Star-Delta Pull up torque vs FL torque **0,48**
 Star-Delta Pull out torque vs FL torque **0,98**
 DOL Starting current vs FL current **7,11**
 Star Delta Starting current vs FL current **2,22**

Rotor Inertia **kgm2**

Bearing DE **6306 - ZZ C3**
 Bearing NDE **6306 - ZZ C3**

WI	Change	date	sign.
Dutchi Motors B.V.		Discription	date
P.O. Box 5390		Drawing made by :	19-04-04
NL-6802 EJ ARNHEM			
Tel : +31-(0)26 - 3541 600		dutchi.motors@dutchi.nl	
Fax : +31-(0)26 - 3541 650		www.dutchi.com	