

Power is our commodity, the world is our market !

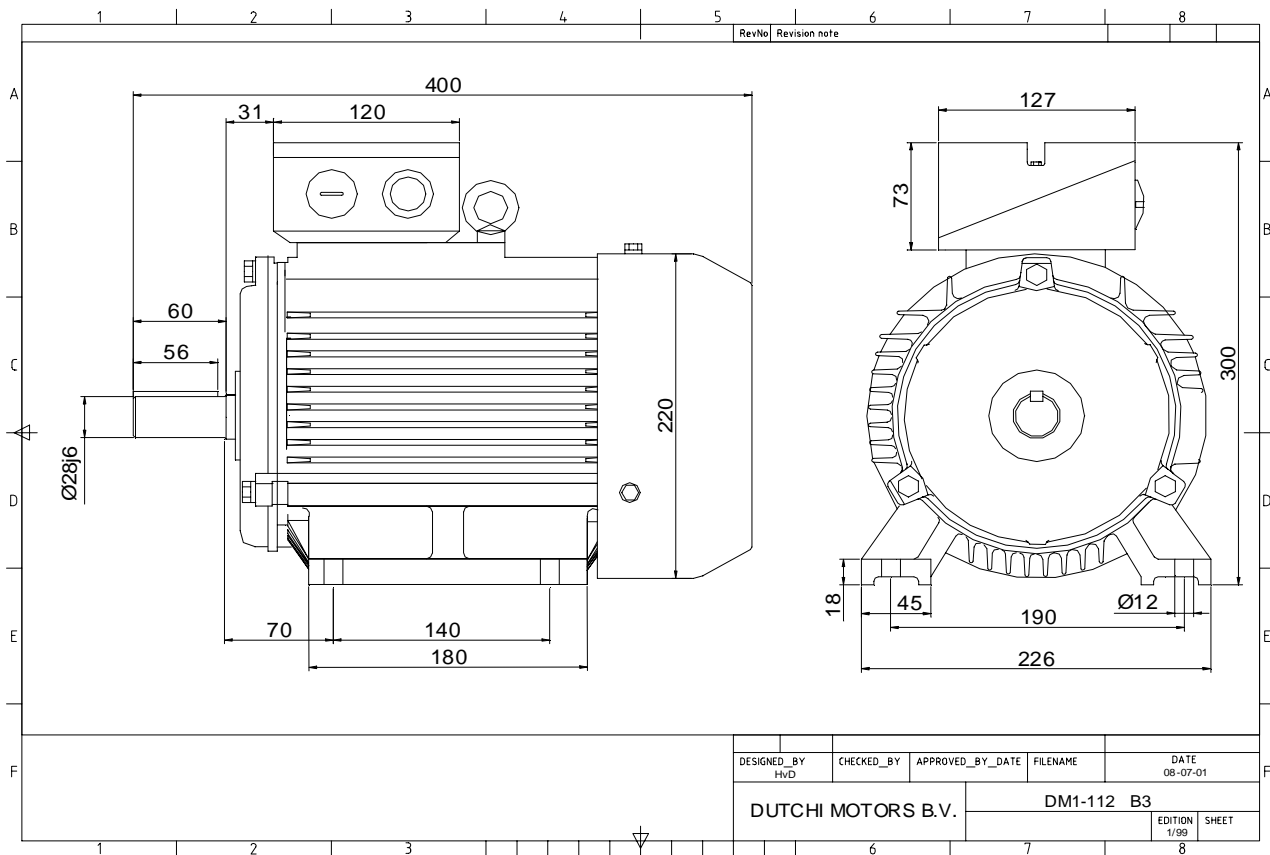

DESIGNED_BY HvD	CHECKED_BY	APPROVED_BY_DATE	FILENAME	DATE 08-07-01
DUTCHI MOTORS B.V.			DM1-112 B3	EDITION 1/99
				SHEET

Specification	IEC 60034-1
Manufacturer	Dutchi Motors B.V.
Motor type	DM1- 112 M2
Rated power	4 kW S1 duty
Speed	2885 r.p.m
Voltage	400 / 690 V
Frequency	50 Hz
Connection	Δ / Y
Amps full load	7,32 / 4,22 A
Amps no-load(400V)	2,00 A
Enclosure	IP 55
Insulation Class	F (temp. rise B (80 K))
Max. coolant temp.	40°C
Max. altitude	1.000 mtr, above sea level
Comment	3 x PTC 150°C
Cable entries	2 x M32x1,5 + 1 x M20x1,5 (ptc)
Feature	Cast-iron motor
Weight	40,0 kg
Catalog no.	11132400D
Warranty	12~18 months

Efficiency class	EFF 2
Load data	100% 75% 50% 25%
Efficiency	85,1 86,8 86,8 82,4 %
Power factor	0,93 0,91 0,83 0,62
Sound pressure level (1m)	65,2 dB(A)
Resistance R20 (open)	4,80 Ω
Resistance R20	Δ 3,20 Ω
Full load torque	13,24 Nm
DOL Starting torque vs FL torque	2,08
DOL Pull up torque vs FL torque	1,63
DOL Pull out torque vs FL torque	3,47
Star-Delta Starting torque vs FL torque	0,65
Star-Delta Pull up torque vs FL torque	0,51
Star-Delta Pull out torque vs FL torque	1,08
DOL Starting current vs FL current	6,87
Star Delta Starting current vs FL current	2,15
Rotor Inertia	0,0055 kgm ²
Bearing DE	6306 - ZZ C3
Bearing NDE	6306 - ZZ C3

Extras / Options :

WI	Change	date	sign.
Dutchi Motors B.V. P.O. Box 5390 NL-6802 EJ ARNHEM Tel : +31-(0)26 - 3541 600 Fax : +31-(0)26 - 3541 650		Discription Drawing made by :	date 19-04-04
		sign. HvD	
		dutchi.motors@dutchi.nl www.dutchi.com	

Power is our commodity, the world is our market !

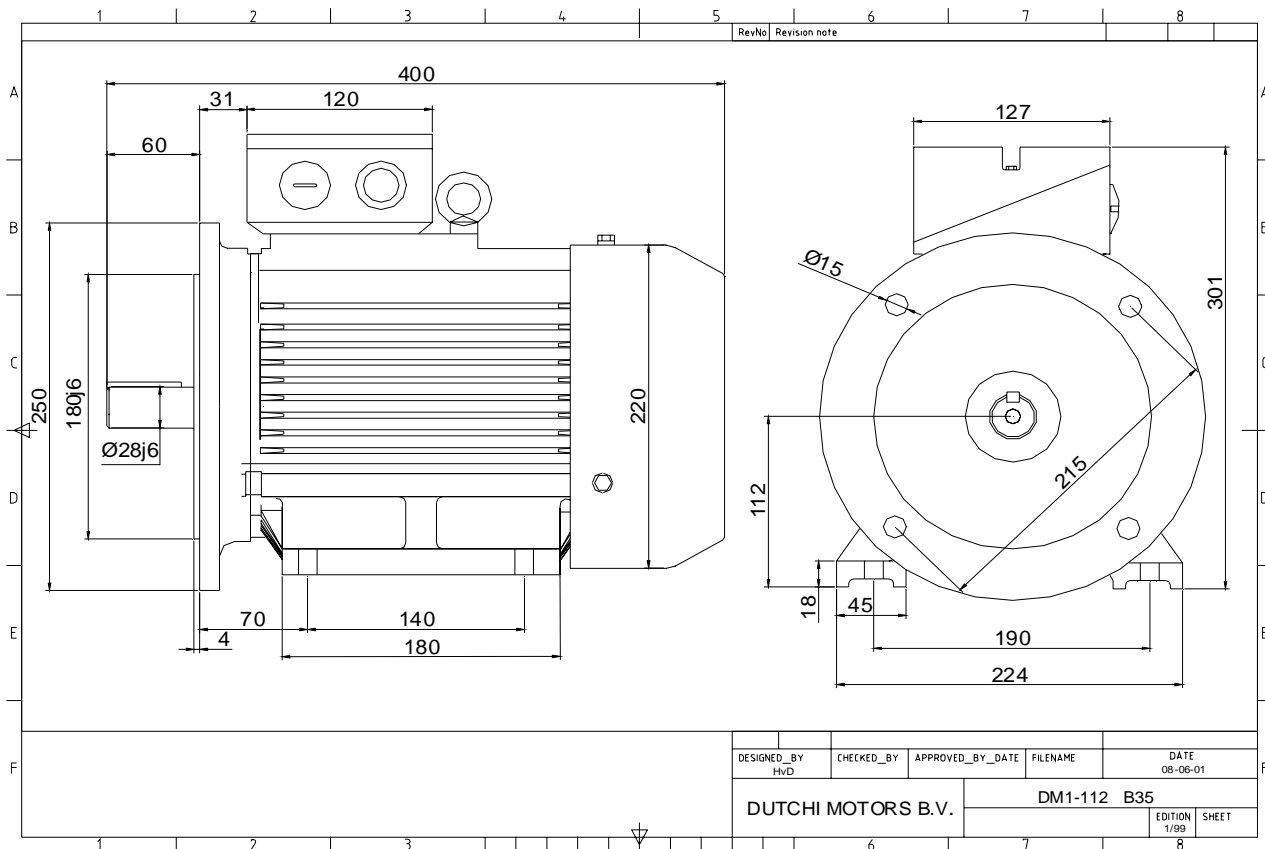

Specification **IEC 60034-1**
 Manufacturer **Dutchi Motors B.V.**
 Motor type **DM1- 112 M2**
 Rated power **4** kW **S1** duty
 Speed **2885** r.p.m
 Voltage **400** / **690** V
 Frequency **50** Hz
 Connection **Δ** / **Y**
 Amps full load **7,32** / **4,22** A
 Amps no-load(400V) **2,00** A
 Enclosure **IP 55**
 Insulation Class **F (temp. rise B (80 K))**

Max. coolant temp. **40°C**
 Max. altitude **1.000** mtr, above sea level
 Comment **3 x PTC 150°C**
 Cable entries **2 x M32x1,5 + 1 x M20x1,5 (ptc)**

Feature **Cast-iron motor**
 Weight **40,0** kg
 Catalog no. **11532400D**
 Warranty **12~18 months**

Efficiency class **EFF 2**
 Load data 100% 75% 50% 25%
 Efficiency **85,1 86,8 86,8 82,4** %
 Power factor **0,93 0,91 0,83 0,62**

Sound pressure level (1m) **65,2** dB(A)
 Resistance R20 (open) **4,80** Ω
 Resistance R20 **Δ 3,20** Ω

Full load torque **13,24** Nm
 DOL Starting torque vs FL torque **2,08**
 DOL Pull up torque vs FL torque **1,63**
 DOL Pull out torque vs FL torque **3,47**
 Star-Delta Starting torque vs FL torque **0,65**
 Star-Delta Pull up torque vs FL torque **0,51**
 Star-Delta Pull out torque vs FL torque **1,08**
 DOL Starting current vs FL current **6,87**
 Star Delta Starting current vs FL current **2,15**
 Rotor Inertia **0,0055** kgm²

Bearing DE **6306 - ZZ C3**
 Bearing NDE **6306 - ZZ C3**

Extras / Options :

WI	Change	date	sign.
Dutchi Motors B.V. P.O. Box 5390 NL-6802 EJ ARNHEM Tel : +31-(0)26 - 3541 600 Fax : +31-(0)26 - 3541 650		Description	date
		Drawing made by :	19-04-04
		dutchi.motors@dutchi.nl www.dutchi.com	

Power is our commodity, the world is our market !

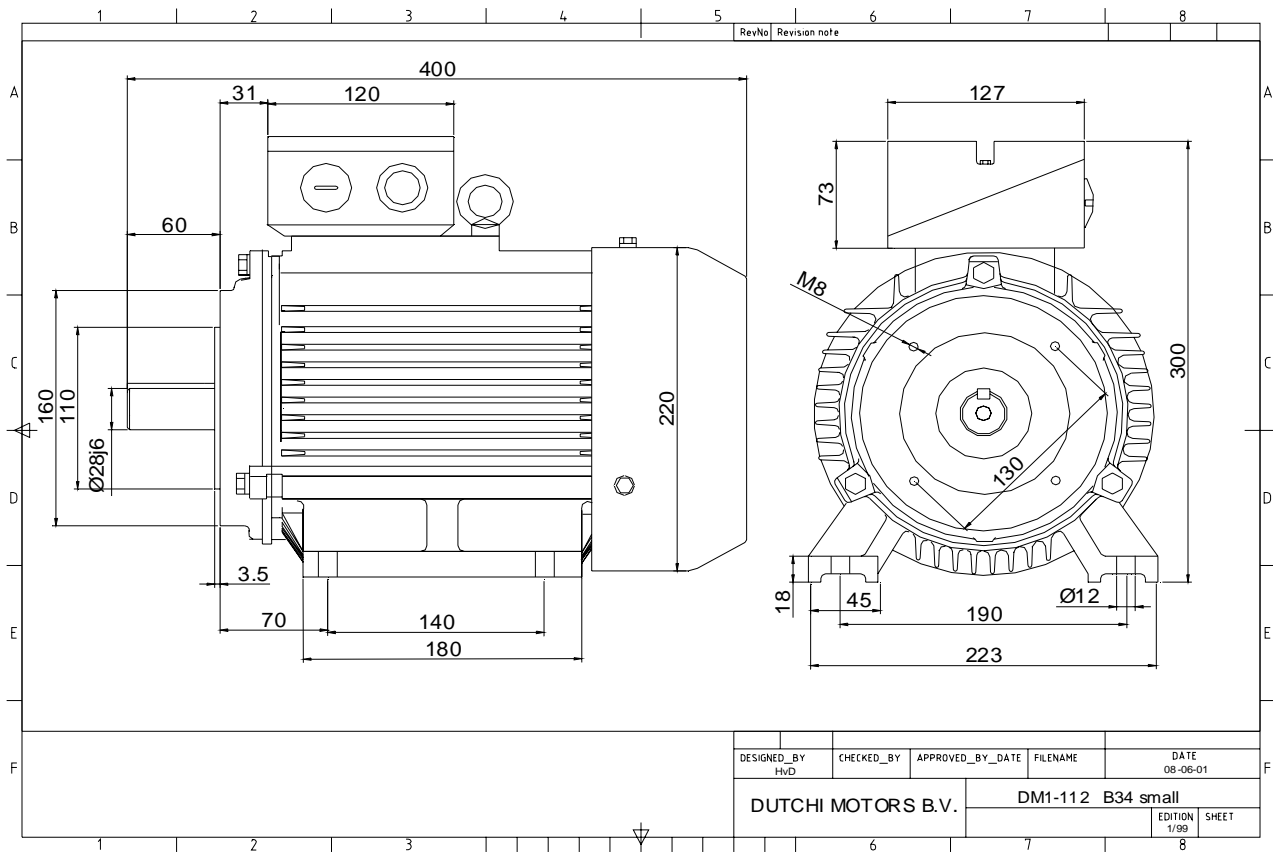

Specification **IEC 60034-1**
 Manufacturer **Dutchi Motors B.V.**
 Motor type **DM1- 112 M2**
 Rated power **4** kW **S1** duty
 Speed **2885** r.p.m
 Voltage **400** / **690** V
 Frequency **50** Hz
 Connection **Δ** / **Y**
 Amps full load **7,32** / **4,22** A
 Amps no-load(400V) **2,00** A
 Enclosure **IP 55**
 Insulation Class **F (temp. rise B (80 K))**

Max. coolant temp. **40°C**
 Max. altitude **1.000** mtr, above sea level
 Comment **3 x PTC 150°C**
 Cable entries **2 x M32x1,5 + 1 x M20x1,5 (ptc)**

Feature **Cast-iron motor**
 Weight **40,0** kg
 Catalog no. **11632400D**
 Warranty **12~18 months**

Efficiency class **EFF 2**
 Load data 100% 75% 50% 25%
 Efficiency **85,1 86,8 86,8 82,4** %
 Power factor **0,93 0,91 0,83 0,62**

Sound pressure level (1m) **65,2** dB(A)
 Resistance R20 (open) **4,80** Ω
 Resistance R20 **Δ 3,20** Ω

Full load torque **13,24** Nm
 DOL Starting torque vs FL torque **2,08**
 DOL Pull up torque vs FL torque **1,63**
 DOL Pull out torque vs FL torque **3,47**
 Star-Delta Starting torque vs FL torque **0,65**
 Star-Delta Pull up torque vs FL torque **0,51**
 Star-Delta Pull out torque vs FL torque **1,08**
 DOL Starting current vs FL current **6,87**
 Star Delta Starting current vs FL current **2,15**
 Rotor Inertia **0,0055** kgm²

Bearing DE **6306 - ZZ C3**
 Bearing NDE **6306 - ZZ C3**

Extras / Options :

WI	Change	date	sign.
Dutchi Motors B.V.		Description	date
P.O. Box 5390		Drawing made by :	19-04-04
NL-6802 EJ ARNHEM			
Tel : +31-(0)26 - 3541 600		dutchi.motors@dutchi.nl	
Fax : +31-(0)26 - 3541 650		www.dutchi.com	

Power is our commodity, the world is our market !

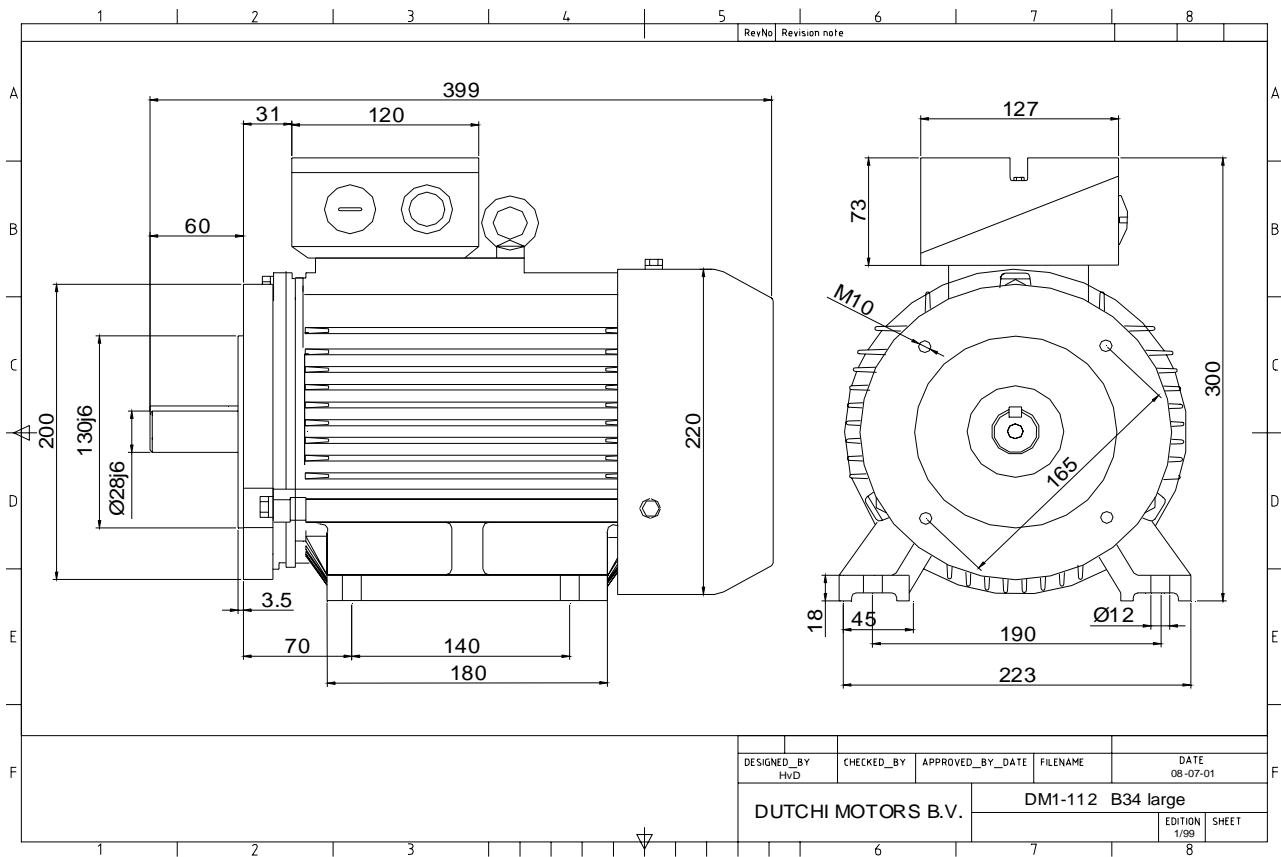

Specification **IEC 60034-1**
 Manufacturer **Dutchi Motors B.V.**
 Motor type **DM1- 112 M2**
 Rated power **4** kW **S1** duty
 Speed **2885** r.p.m
 Voltage **400** / **690** V
 Frequency **50** Hz
 Connection **Δ** / **Y**
 Amps full load **7,32** / **4,22** A
 Amps no-load(400V) **2,00** A
 Enclosure **IP 55**
 Insulation Class **F (temp. rise B (80 K))**

Max. coolant temp. **40°C**
 Max. altitude **1.000** mtr, above sea level
 Comment **3 x PTC 150°C**
 Cable entries **2 x M32x1,5 + 1 x M20x1,5 (ptc)**

Feature **Cast-iron motor**
 Weight **40,0** kg
 Catalog no. **11732400D**
 Warranty **12~18 months**

Efficiency class **EFF 2**
 Load data 100% 75% 50% 25%
 Efficiency **85,1 86,8 86,8 82,4** %
 Power factor **0,93 0,91 0,83 0,62**

Sound pressure level (1m) **65,2** dB(A)
 Resistance R20 (open) **4,80** Ω
 Resistance R20 **Δ 3,20** Ω

Full load torque **13,24** Nm
 DOL Starting torque vs FL torque **2,08**
 DOL Pull up torque vs FL torque **1,63**
 DOL Pull out torque vs FL torque **3,47**
 Star-Delta Starting torque vs FL torque **0,65**
 Star-Delta Pull up torque vs FL torque **0,51**
 Star-Delta Pull out torque vs FL torque **1,08**
 DOL Starting current vs FL current **6,87**
 Star Delta Starting current vs FL current **2,15**
 Rotor Inertia **0,0055** kgm²

Bearing DE **6306 - ZZ C3**
 Bearing NDE **6306 - ZZ C3**

Extras / Options :

WI	Change	date	sign.
Dutchi Motors B.V. P.O. Box 5390 NL-6802 EJ ARNHEM Tel : +31-(0)26 - 3541 600 Fax : +31-(0)26 - 3541 650		Description	date
		Drawing made by :	19-04-04
		dutchi.motors@dutchi.nl www.dutchi.com	

Power is our commodity, the world is our market !

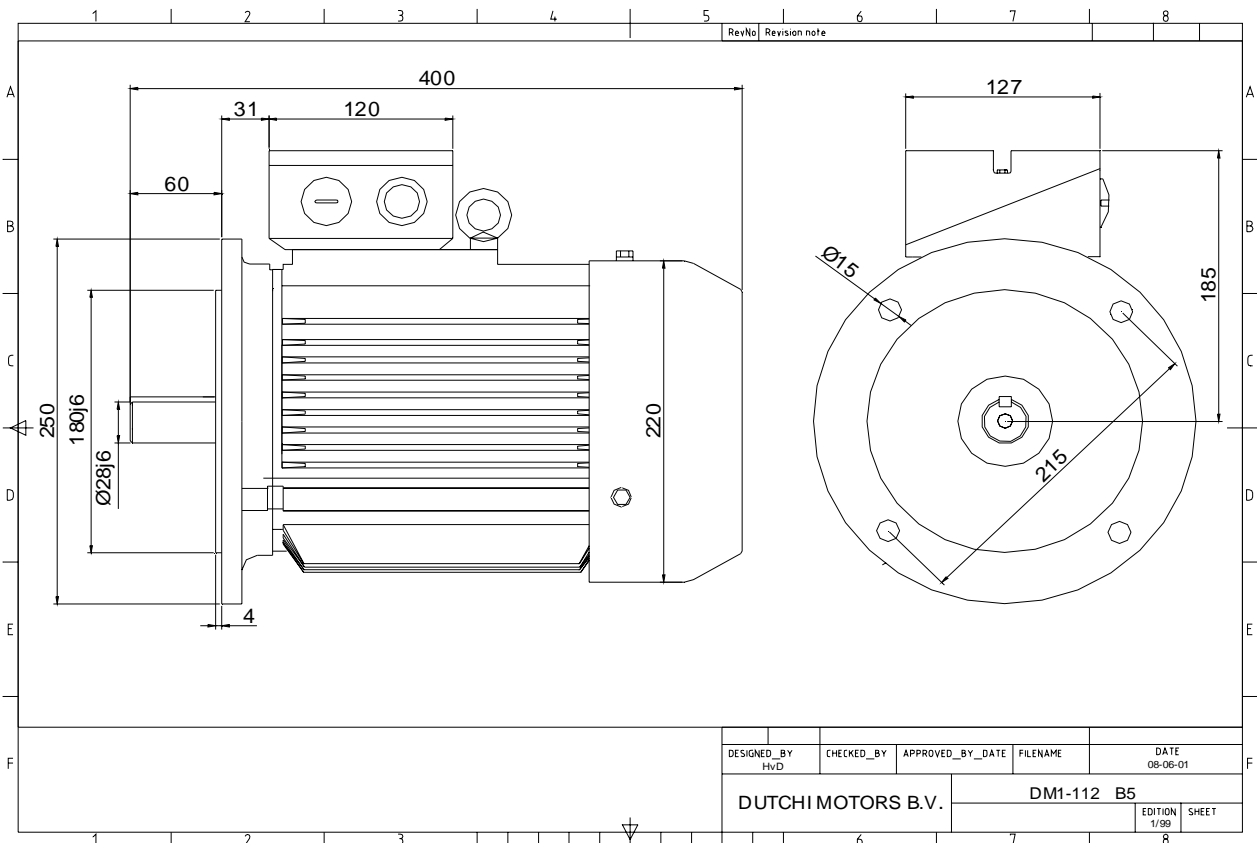

Specification **IEC 60034-1**
 Manufacturer **Dutchi Motors B.V.**
 Motor type **DM1- 112 M2**
 Rated power **4** kW **S1** duty
 Speed **2885** r.p.m
 Voltage **400** / **690** V
 Frequency **50** Hz
 Connection **Δ** / **Y**
 Amps full load **7,32** / **4,22** A
 Amps no-load(400V) **2,00** A
 Enclosure **IP 55**
 Insulation Class **F (temp. rise B (80 K))**

Max. coolant temp. **40°C**
 Max. altitude **1.000** mtr, above sea level
 Comment **3 x PTC 150°C**
 Cable entries **2 x M32x1,5 + 1 x M20x1,5 (ptc)**

Feature **Cast-iron motor**
 Weight **40,0** kg
 Catalog no. **11232400D**
 Warranty **12~18 months**

Efficiency class **EFF 2**
 Load data 100% 75% 50% 25%
 Efficiency **85,1 86,8 86,8 82,4** %
 Power factor **0,93 0,91 0,83 0,62**

Sound pressure level (1m) **65,2** dB(A)
 Resistance R20 (open) **4,80** Ω
 Resistance R20 **Δ 3,20** Ω

Full load torque **13,24** Nm
 DOL Starting torque vs FL torque **2,08**
 DOL Pull up torque vs FL torque **1,63**
 DOL Pull out torque vs FL torque **3,47**
 Star-Delta Starting torque vs FL torque **0,65**
 Star-Delta Pull up torque vs FL torque **0,51**
 Star-Delta Pull out torque vs FL torque **1,08**
 DOL Starting current vs FL current **6,87**
 Star Delta Starting current vs FL current **2,15**
 Rotor Inertia **0,0055** kgm²

Bearing DE **6306 - ZZ C3**
 Bearing NDE **6306 - ZZ C3**

Extras / Options :

WI	Change	date	sign.
Dutchi Motors B.V. P.O. Box 5390 NL-6802 EJ ARNHEM Tel : +31-(0)26 - 3541 600 Fax : +31-(0)26 - 3541 650		Discription Drawing made by :	date 19-04-04 sign. HvD
dutchi.motors@dutchi.nl www.dutchi.com			

Power is our commodity, the world is our market !

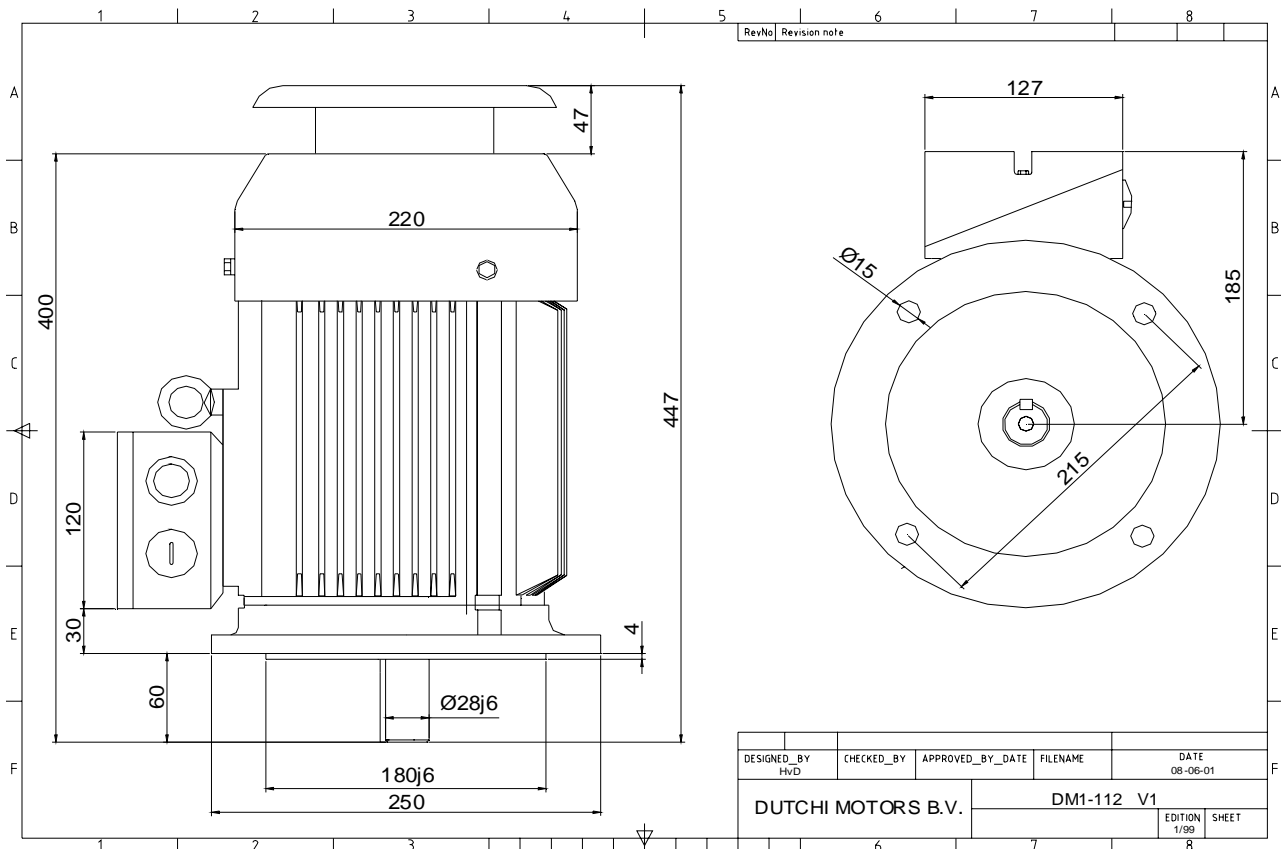

Specification **IEC 60034-1**
 Manufacturer **Dutchi Motors B.V.**
 Motor type **DM1- 112 M2**
 Rated power **4** kW **S1** duty
 Speed **2885** r.p.m
 Voltage **400** / **690** V
 Frequency **50** Hz
 Connection **Δ** / **Y**
 Amps full load **7,32** / **4,22** A
 Amps no-load(400V) **2,00** A
 Enclosure **IP 55**
 Insulation Class **F (temp. rise B (80 K))**

Max. coolant temp. **40°C**
 Max. altitude **1.000** mtr, above sea level
 Comment **3 x PTC 150°C**
 Cable entries **2 x M32x1,5 + 1 x M20x1,5 (ptc)**

Feature **Cast-iron motor**
 Weight **40,0** kg
 Catalog no. **11032400D**
 Warranty **12~18 months**

Efficiency class **EFF 2**
 Load data 100% 75% 50% 25%
 Efficiency **85,1 86,8 86,8 82,4** %
 Power factor **0,93 0,91 0,83 0,62**

Sound pressure level (1m) **65,2** dB(A)
 Resistance R20 (open) **4,80** Ω
 Resistance R20 **Δ 3,20** Ω

Full load torque **13,24** Nm
 DOL Starting torque vs FL torque **2,08**
 DOL Pull up torque vs FL torque **1,63**
 DOL Pull out torque vs FL torque **3,47**
 Star-Delta Starting torque vs FL torque **0,65**
 Star-Delta Pull up torque vs FL torque **0,51**
 Star-Delta Pull out torque vs FL torque **1,08**
 DOL Starting current vs FL current **6,87**
 Star Delta Starting current vs FL current **2,15**
 Rotor Inertia **0,0055** kgm2

Bearing DE **6306 - ZZ C3**
 Bearing NDE **6306 - ZZ C3**

Extras / Options :

WI	Change	date	sign.
Dutchi Motors B.V.		Description	date
P.O. Box 5390		Drawing made by :	19-04-04
NL-6802 EJ ARNHEM			
Tel : +31-(0)26 - 3541 600		dutchi.motors@dutchi.nl	
Fax : +31-(0)26 - 3541 650		www.dutchi.com	

Power is our commodity, the world is our market !

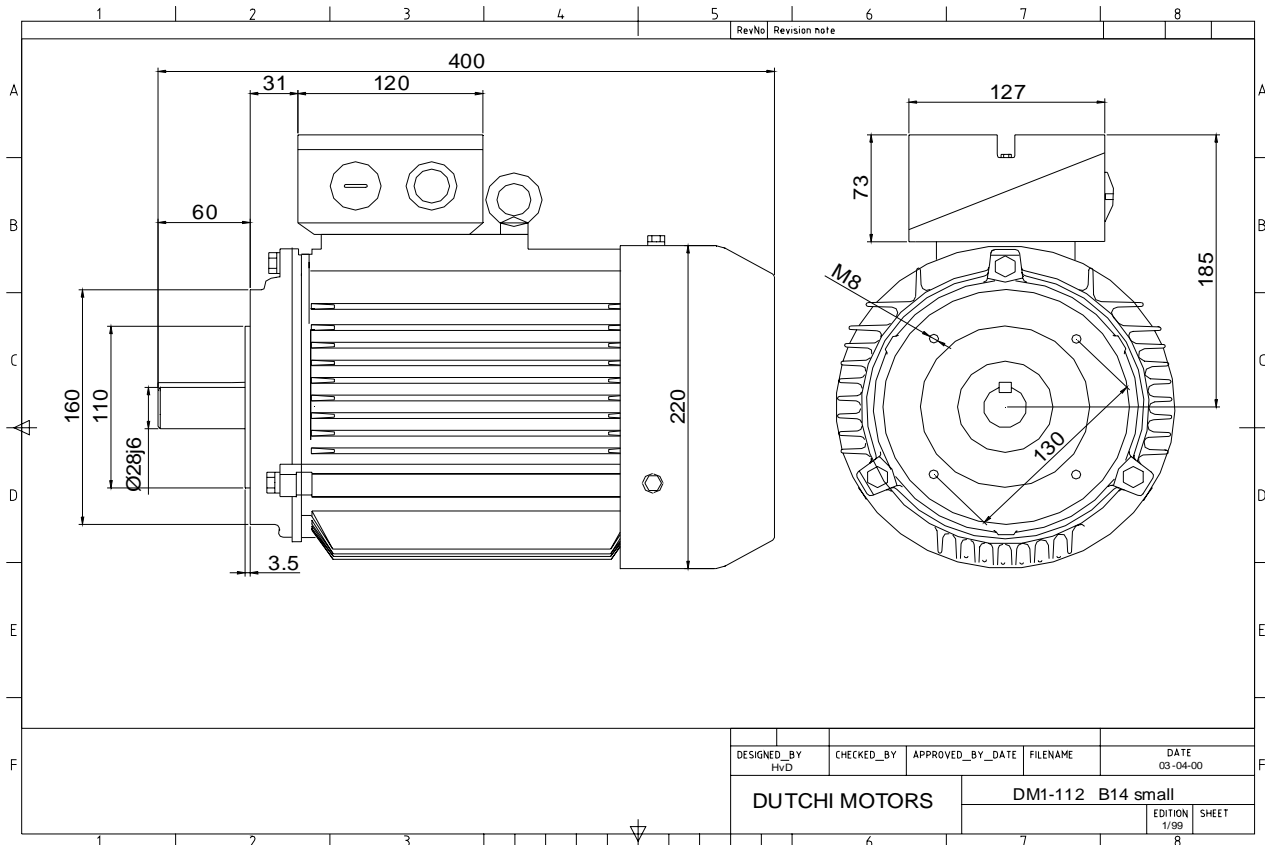

Specification **IEC 60034-1**
 Manufacturer **Dutchi Motors B.V.**
 Motor type **DM1- 112 M2**
 Rated power **4** kW **S1** duty
 Speed **2885** r.p.m
 Voltage **400** / **690** V
 Frequency **50** Hz
 Connection **Δ** / **Y**
 Amps full load **7,32** / **4,22** A
 Amps no-load(400V) **2,00** A
 Enclosure **IP 55**
 Insulation Class **F (temp. rise B (80 K))**

Max. coolant temp. **40°C**
 Max. altitude **1.000** mtr, above sea level
 Comment **3 x PTC 150°C**
 Cable entries **2 x M32x1,5 + 1 x M20x1,5 (ptc)**

Feature **Cast-iron motor**
 Weight **40,0** kg
 Catalog no. **11332400D**
 Warranty **12~18 months**

Efficiency class **EFF 2**
 Load data 100% 75% 50% 25%
 Efficiency **85,1 86,8 86,8 82,4** %
 Power factor **0,93 0,91 0,83 0,62**

Sound pressure level (1m) **65,2** dB(A)
 Resistance R20 (open) **4,80** Ω
 Resistance R20 **Δ 3,20** Ω

Full load torque **13,24** Nm
 DOL Starting torque vs FL torque **2,08**
 DOL Pull up torque vs FL torque **1,63**
 DOL Pull out torque vs FL torque **3,47**
 Star-Delta Starting torque vs FL torque **0,65**
 Star-Delta Pull up torque vs FL torque **0,51**
 Star-Delta Pull out torque vs FL torque **1,08**
 DOL Starting current vs FL current **6,87**
 Star Delta Starting current vs FL current **2,15**
 Rotor Inertia **0,0055** kgm2

Bearing DE **6306 - ZZ C3**
 Bearing NDE **6306 - ZZ C3**

Extras / Options :

WI	Change	date	sign.
Dutchi Motors B.V. P.O. Box 5390 NL-6802 EJ ARNHEM Tel : +31-(0)26 - 3541 600 Fax : +31-(0)26 - 3541 650		Description	date
		Drawing made by :	19-04-04
		dutchi.motors@dutchi.nl www.dutchi.com	

Power is our commodity, the world is our market !

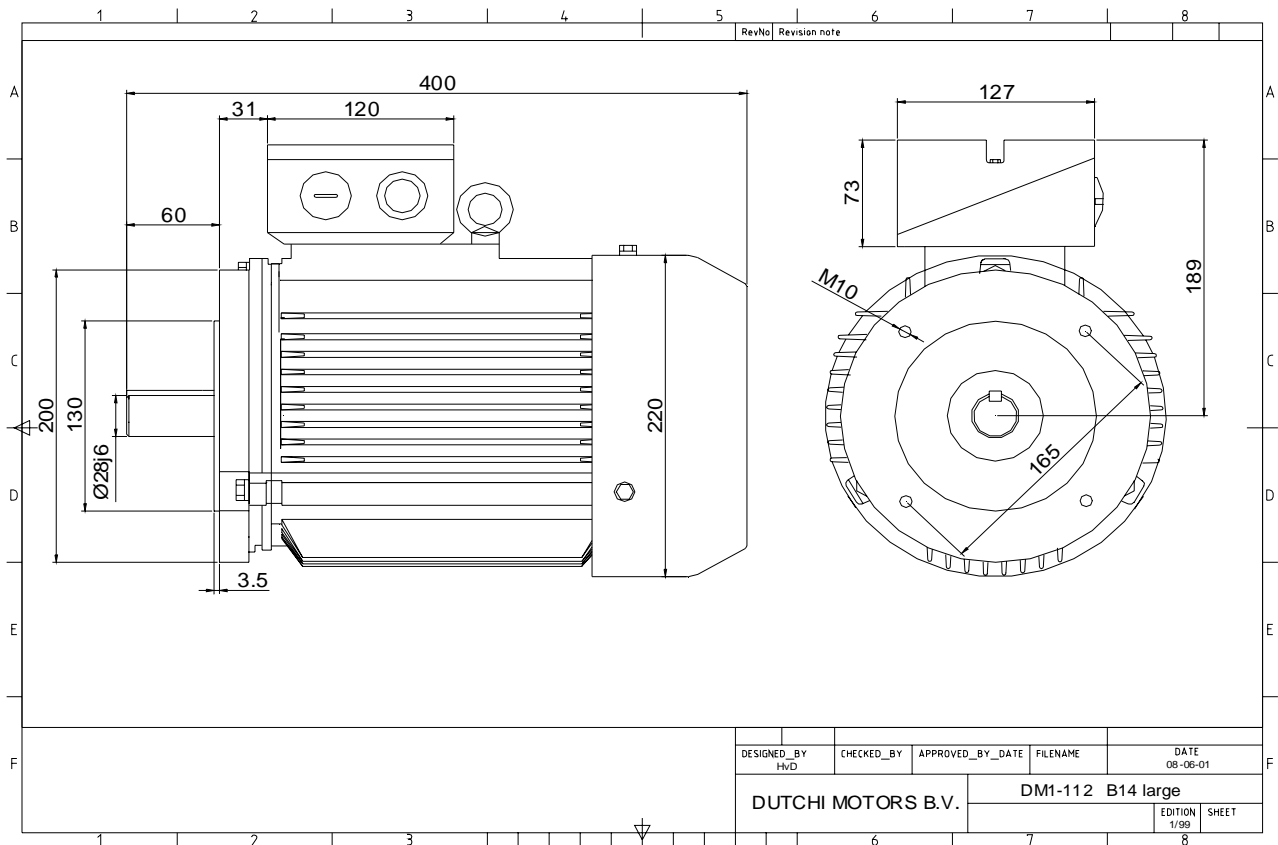

Specification **IEC 60034-1**
 Manufacturer **Dutchi Motors B.V.**
 Motor type **DM1- 112 M2**
 Rated power **4** kW **S1** duty
 Speed **2885** r.p.m
 Voltage **400** / **690** V
 Frequency **50** Hz
 Connection **Δ** / **Y**
 Amps full load **7,32** / **4,22** A
 Amps no-load(400V) **2,00** A
 Enclosure **IP 55**
 Insulation Class **F (temp. rise B (80 K))**

Max. coolant temp. **40°C**
 Max. altitude **1.000** mtr, above sea level
 Comment **3 x PTC 150°C**
 Cable entries **2 x M32x1,5 + 1 x M20x1,5 (ptc)**

Feature **Cast-iron motor**
 Weight **40,0** kg
 Catalog no. **11432400D**
 Warranty **12~18 months**

Efficiency class **EFF 2**
 Load data 100% 75% 50% 25%
 Efficiency **85,1 86,8 86,8 82,4** %
 Power factor **0,93 0,91 0,83 0,62**

Sound pressure level (1m) **65,2** dB(A)
 Resistance R20 (open) **4,80** Ω
 Resistance R20 **Δ 3,20** Ω

Full load torque **13,24** Nm
 DOL Starting torque vs FL torque **2,08**
 DOL Pull up torque vs FL torque **1,63**
 DOL Pull out torque vs FL torque **3,47**
 Star-Delta Starting torque vs FL torque **0,65**
 Star-Delta Pull up torque vs FL torque **0,51**
 Star-Delta Pull out torque vs FL torque **1,08**
 DOL Starting current vs FL current **6,87**
 Star Delta Starting current vs FL current **2,15**
 Rotor Inertia **0,0055** kgm2

Bearing DE **6306 - ZZ C3**
 Bearing NDE **6306 - ZZ C3**

Extras / Options :

WI	Change	date	sign.
Dutchi Motors B.V.		Description	date
P.O. Box 5390		Drawing made by :	19-04-04
NL-6802 EJ ARNHEM			
Tel : +31-(0)26 - 3541 600		dutchi.motors@dutchi.nl	
Fax : +31-(0)26 - 3541 650		www.dutchi.com	