

Power is our commodity, the world is our market !

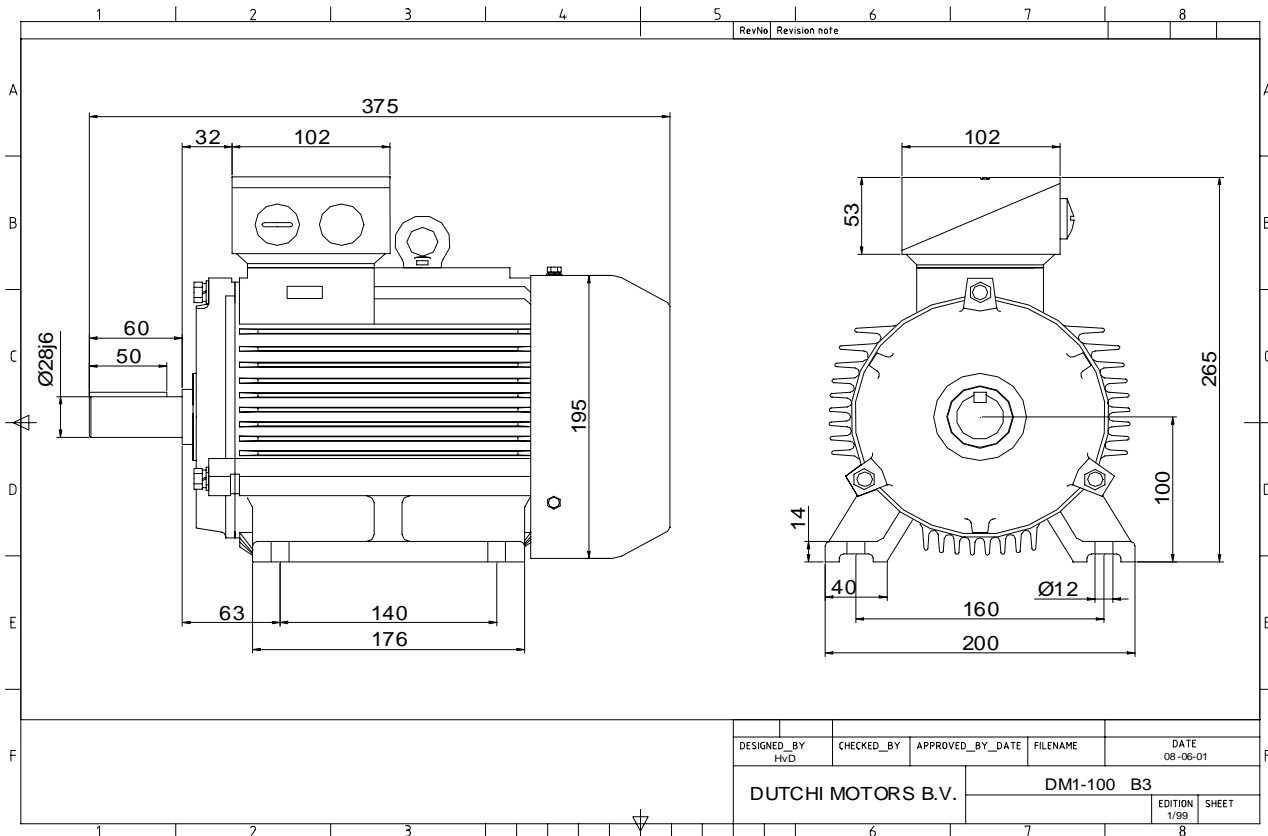

DESIGNED_BY HVD	CHECKED_BY	APPROVED_BY_DATE	FILENAME	DATE 08-06-01
DUTCHI MOTORS B.V.			DM1-100 B3	EDITION 1/99
				SHEET

Specification **IEC 60034-1**  
 Manufacturer **Dutchi Motors B.V.**  
 Motor type **DM1- 100 L2**  
 Rated power **3** kW **S1** duty  
 Speed **2850** r.p.m  
 Voltage **230 / 400** V  
 Frequency **50** Hz  
 Connection **Δ / Y**  
 Amps full load **10,28 / 5,93** A  
 Amps no-load(400V) **2,40** A  
 Enclosure **IP 55**  
 Insulation Class **F (temp. rise B (80 K))**

Max. coolant temp. **40°C**  
 Max. altitude **1.000** mtr, above sea level  
 Comment **3 x PTC 150°C**  
 Cable entries **2 x M25x1,5 + 1 x M20x1,5 (ptc)**

Feature **Cast-iron motor**  
 Weight **33,0** kg  
 Catalog no. **11122300D**  
 Warranty **12~18 months**

Efficiency class **EFF 2**  
 Load data 100% 75% 50% 25%  
 Efficiency **82,6 82,5 80,2 71,3** %  
 Power factor **0,88 0,84 0,75 0,56**

Sound pressure level (1m) **64,0** dB(A)  
 Resistance R20 (open) **1,80** Ω  
 Resistance R20 **Y 3,60** Ω

Full load torque **10,05** Nm  
 DOL Starting torque vs FL torque **2,91**  
 DOL Pull up torque vs FL torque **1,96**  
 DOL Pull out torque vs FL torque **3,25**  
 Star-Delta Starting torque vs FL torque **Y - motor**  
 Star-Delta Pull up torque vs FL torque **Y - motor**  
 Star-Delta Pull out torque vs FL torque **Y - motor**  
 DOL Starting current vs FL current **7,58**  
 Star Delta Starting current vs FL current **Y - motor**  
 Rotor Inertia **0,0029** kgm<sup>2</sup>

Bearing DE **6206 - ZZ C3**  
 Bearing NDE **6206 - ZZ C3**

WI	Change	date	sign.
Dutchi Motors B.V.		Description	date
P.O. Box 5390		Drawing made by :	19-04-04
NL-6802 EJ ARNHEM			
Tel : +31-(0)26 - 3541 600		dutchi.motors@dutchi.nl	
Fax : +31-(0)26 - 3541 650		www.dutchi.com	

Power is our commodity, the world is our market !

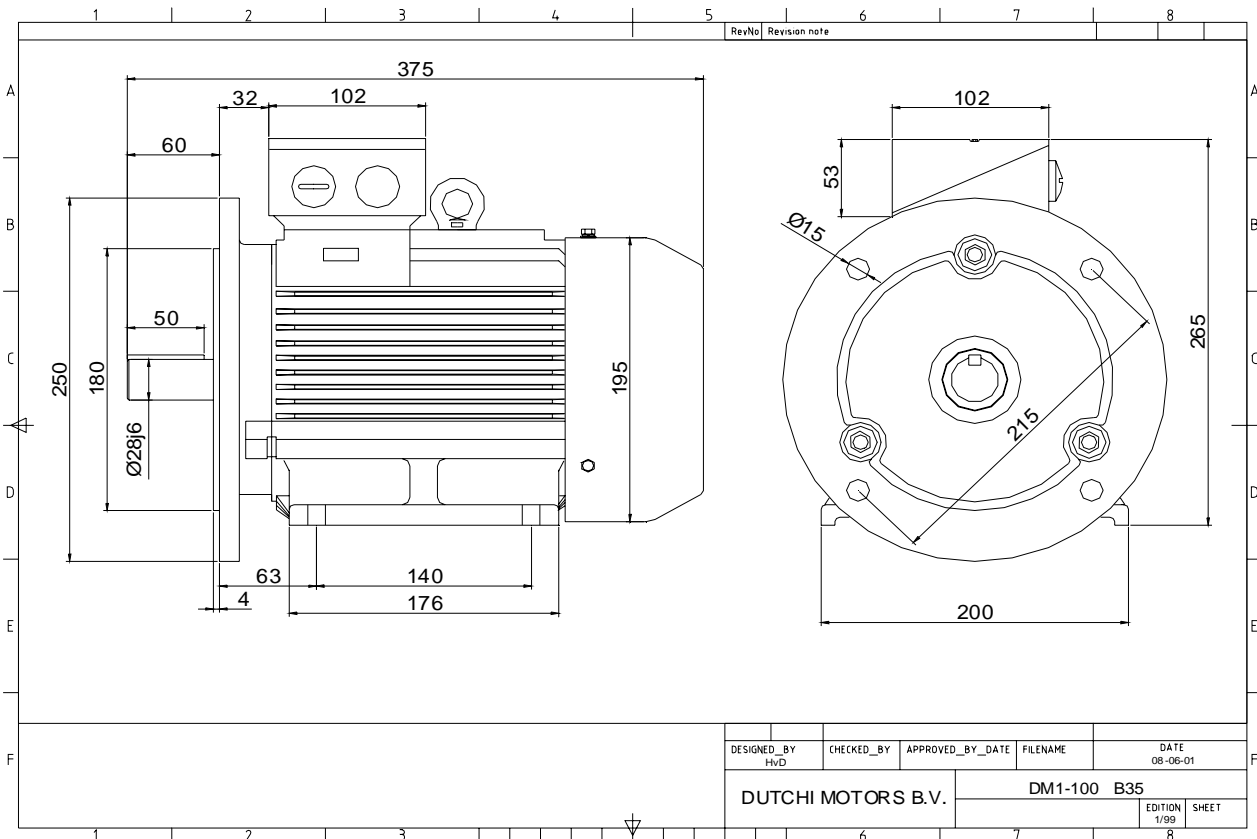

Specification	<b>IEC 60034-1</b>
Manufacturer	<b>Dutchi Motors B.V.</b>
Motor type	<b>DM1- 100 L2</b>
Rated power	<b>3</b> kW <b>S1</b> duty
Speed	<b>2850</b> r.p.m
Voltage	<b>230 / 400</b> V
Frequency	<b>50</b> Hz
Connection	<b>Δ / Y</b>
Amps full load	<b>10,28 / 5,93</b> A
Amps no-load(400V)	<b>2,40</b> A
Enclosure	<b>IP 55</b>
Insulation Class	<b>F (temp. rise B (80 K))</b>
Max. coolant temp.	<b>40°C</b>
Max. altitude	<b>1.000</b> mtr, above sea level
Comment	<b>3 x PTC 150°C</b>
Cable entries	<b>2 x M25x1,5 + 1 x M20x1,5 (ptc)</b>
Feature	<b>Cast-iron motor</b>
Weight	<b>33,0</b> kg
Catalog no.	<b>11522300D</b>
Warranty	<b>12~18 months</b>

Efficiency class	<b>EFF 2</b>			
Load data	100%	75%	50%	25%
Efficiency	<b>82,6</b>	<b>82,5</b>	<b>80,2</b>	<b>71,3</b> %
Power factor	<b>0,88</b>	<b>0,84</b>	<b>0,75</b>	<b>0,56</b>
Sound pressure level (1m)				<b>64,0</b> dB(A)
Resistance R20 (open)				<b>1,80</b> Ω
Resistance R20	<b>Y</b>		<b>3,60</b>	Ω
Full load torque				<b>10,05</b> Nm
DOL Starting torque vs FL torque				<b>2,91</b>
DOL Pull up torque vs FL torque				<b>1,96</b>
DOL Pull out torque vs FL torque				<b>3,25</b>
Star-Delta Starting torque vs FL torque				<b>Y - motor</b>
Star-Delta Pull up torque vs FL torque				<b>Y - motor</b>
Star-Delta Pull out torque vs FL torque				<b>Y - motor</b>
DOL Starting current vs FL current				<b>7,58</b>
Star Delta Starting current vs FL current				<b>Y - motor</b>
Rotor Inertia				<b>0,0029</b> kgm <sup>2</sup>
Bearing DE				<b>6206 - ZZ C3</b>
Bearing NDE				<b>6206 - ZZ C3</b>

WI	Change	date	sign.
<b>Dutchi Motors B.V.</b> P.O. Box 5390 NL-6802 EJ ARNHEM Tel : +31-(0)26 - 3541 600 Fax : +31-(0)26 - 3541 650		Discription Drawing made by :	date 19-04-04 sign. HvD
dutchi.motors@dutchi.nl www.dutchi.com			

Power is our commodity, the world is our market !

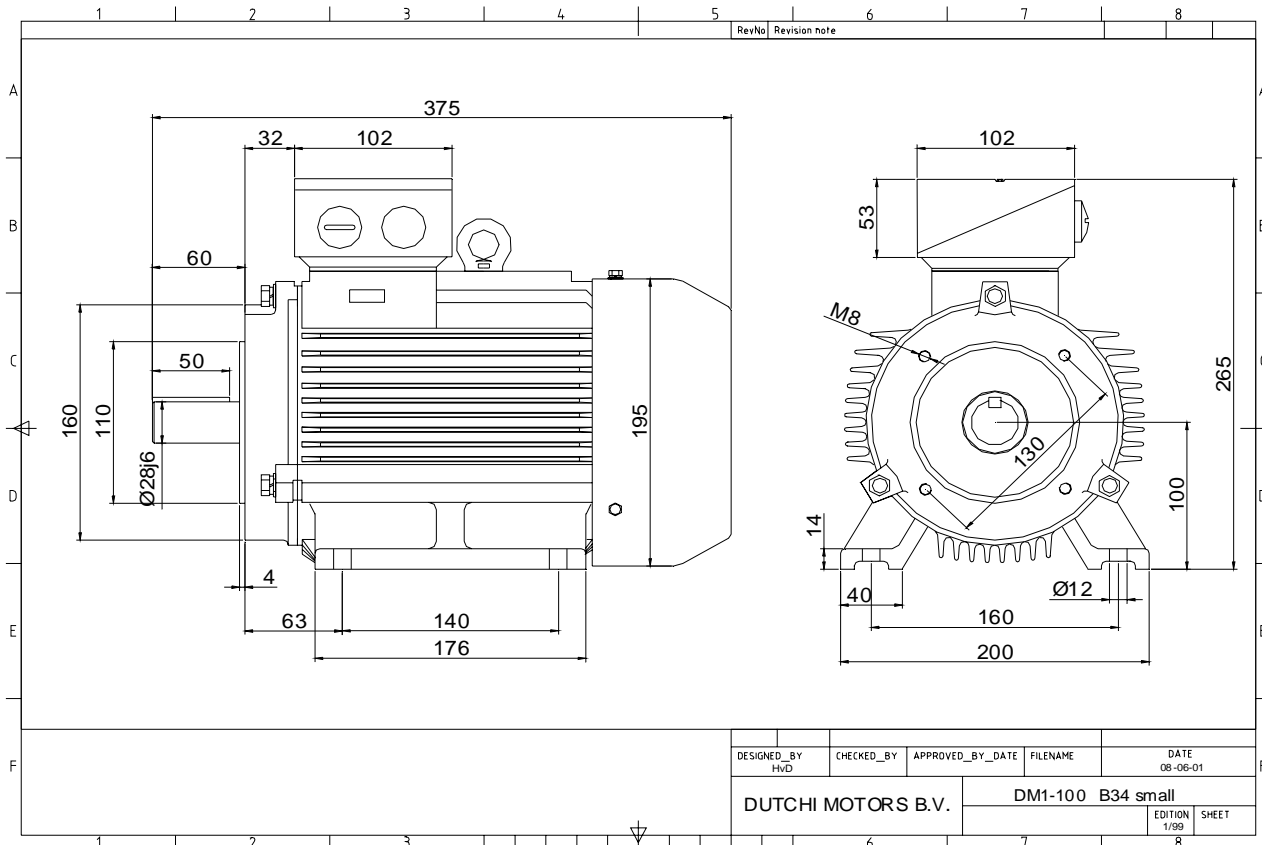

Specification **IEC 60034-1**  
 Manufacturer **Dutchi Motors B.V.**  
 Motor type **DM1- 100 L2**  
 Rated power **3** kW **S1** duty  
 Speed **2850** r.p.m  
 Voltage **230 / 400** V  
 Frequency **50** Hz  
 Connection **Δ / Y**  
 Amps full load **10,28 / 5,93** A  
 Amps no-load(400V) **2,40** A  
 Enclosure **IP 55**  
 Insulation Class **F (temp. rise B (80 K))**

Max. coolant temp. **40°C**  
 Max. altitude **1.000** mtr, above sea level  
 Comment **3 x PTC 150°C**  
 Cable entries **2 x M25x1,5 + 1 x M20x1,5 (ptc)**

Feature **Cast-iron motor**  
 Weight **33,0** kg  
 Catalog no. **11622300D**  
 Warranty **12~18 months**

Efficiency class **EFF 2**  
 Load data 100% 75% 50% 25%  
 Efficiency **82,6 82,5 80,2 71,3** %  
 Power factor **0,88 0,84 0,75 0,56**

Sound pressure level (1m) **64,0** dB(A)  
 Resistance R20 (open) **1,80** Ω  
 Resistance R20 **Y 3,60** Ω

Full load torque **10,05** Nm  
 DOL Starting torque vs FL torque **2,91**  
 DOL Pull up torque vs FL torque **1,96**  
 DOL Pull out torque vs FL torque **3,25**  
 Star-Delta Starting torque vs FL torque **Y - motor**  
 Star-Delta Pull up torque vs FL torque **Y - motor**  
 Star-Delta Pull out torque vs FL torque **Y - motor**  
 DOL Starting current vs FL current **7,58**  
 Star Delta Starting current vs FL current **Y - motor**  
 Rotor Inertia **0,0029** kgm<sup>2</sup>

Bearing DE **6206 - ZZ C3**  
 Bearing NDE **6206 - ZZ C3**

WI	Change	date	sign.
<b>Dutchi Motors B.V.</b> P.O. Box 5390 NL-6802 EJ ARNHEM Tel : +31-(0)26 - 3541 600 Fax : +31-(0)26 - 3541 650		Description	date
		Drawing made by :	19-04-04
		<b>dutchi.motors@dutchi.nl</b> <b>www.dutchi.com</b>	

Power is our commodity, the world is our market !

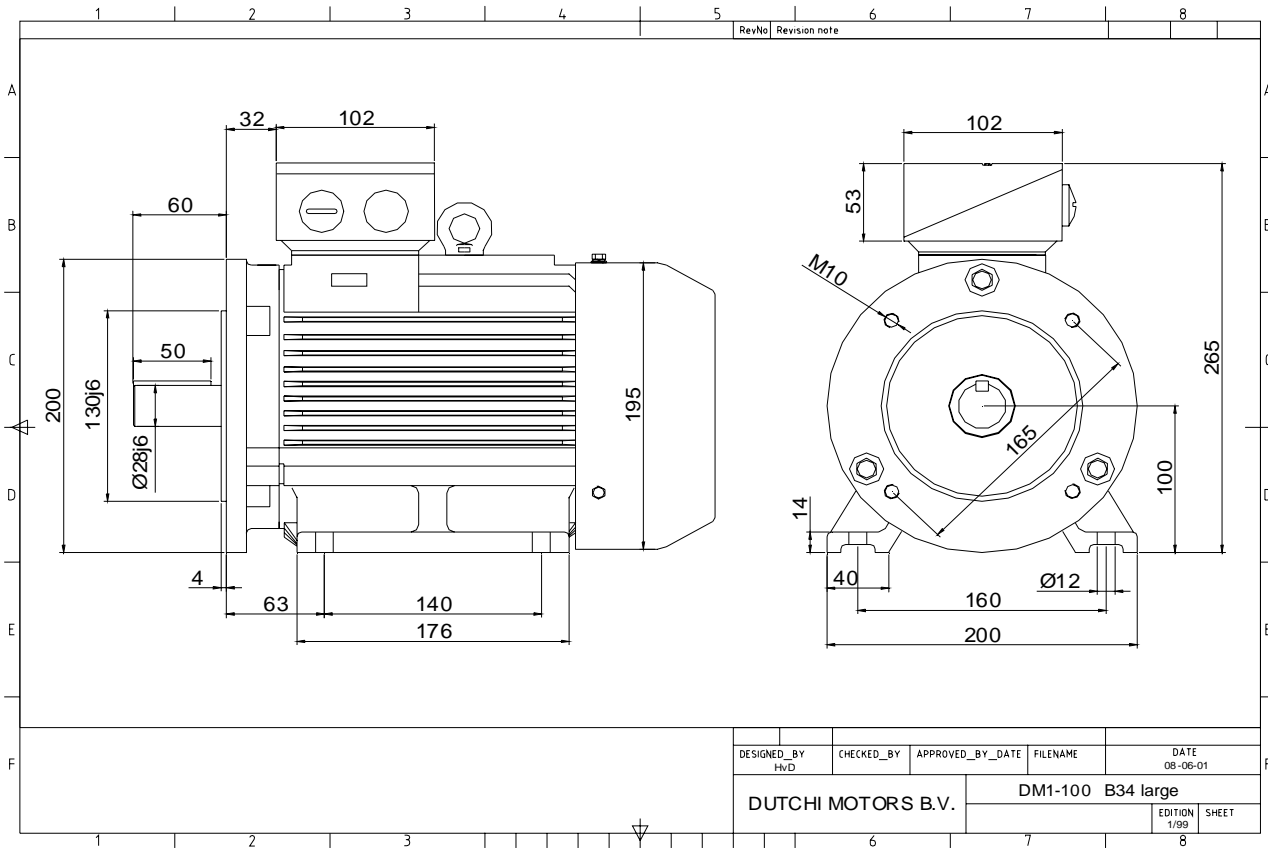

DESIGNED_BY HVD	CHECKED_BY	APPROVED_BY_DATE	FILENAME	DATE 08-06-01
DUTCHI MOTORS B.V.			DM1-100 B34 large	
EDITION 1/99		SHEET		

Specification	<b>IEC 60034-1</b>
Manufacturer	<b>Dutchi Motors B.V.</b>
Motor type	<b>DM1- 100 L2</b>
Rated power	<b>3</b> kW <b>S1</b> duty
Speed	<b>2850</b> r.p.m
Voltage	<b>230 / 400</b> V
Frequency	<b>50</b> Hz
Connection	<b>Δ / Y</b>
Amps full load	<b>10,28 / 5,93</b> A
Amps no-load(400V)	<b>2,40</b> A
Enclosure	<b>IP 55</b>
Insulation Class	<b>F (temp. rise B (80 K))</b>
Max. coolant temp.	<b>40°C</b>
Max. altitude	<b>1.000</b> mtr, above sea level
Comment	<b>3 x PTC 150°C</b>
Cable entries	<b>2 x M25x1,5 + 1 x M20x1,5 (ptc)</b>
Feature	<b>Cast-iron motor</b>
Weight	<b>33,0</b> kg
Catalog no.	<b>11722300D</b>
Warranty	<b>12~18 months</b>

Efficiency class	<b>EFF 2</b>			
Load data	100%	75%	50%	25%
Efficiency	<b>82,6</b>	<b>82,5</b>	<b>80,2</b>	<b>71,3</b> %
Power factor	<b>0,88</b>	<b>0,84</b>	<b>0,75</b>	<b>0,56</b>
Sound pressure level (1m)				<b>64,0</b> dB(A)
Resistance R20 (open)				<b>1,80</b> Ω
Resistance R20	<b>Y</b>		<b>3,60</b>	Ω
Full load torque				<b>10,05</b> Nm
DOL Starting torque vs FL torque				<b>2,91</b>
DOL Pull up torque vs FL torque				<b>1,96</b>
DOL Pull out torque vs FL torque				<b>3,25</b>
Star-Delta Starting torque vs FL torque				<b>Y - motor</b>
Star-Delta Pull up torque vs FL torque				<b>Y - motor</b>
Star-Delta Pull out torque vs FL torque				<b>Y - motor</b>
DOL Starting current vs FL current				<b>7,58</b>
Star Delta Starting current vs FL current				<b>Y - motor</b>
Rotor Inertia				<b>0,0029</b> kgm <sup>2</sup>
Bearing DE				<b>6206 - ZZ C3</b>
Bearing NDE				<b>6206 - ZZ C3</b>

WI	Change	date	sign.
Dutchi Motors B.V.		Description	date
P.O. Box 5390		Drawing made by :	19-04-04
NL-6802 EJ ARNHEM			
Tel : +31-(0)26 - 3541 600		dutchi.motors@dutchi.nl	
Fax : +31-(0)26 - 3541 650		www.dutchi.com	

Power is our commodity, the world is our market !

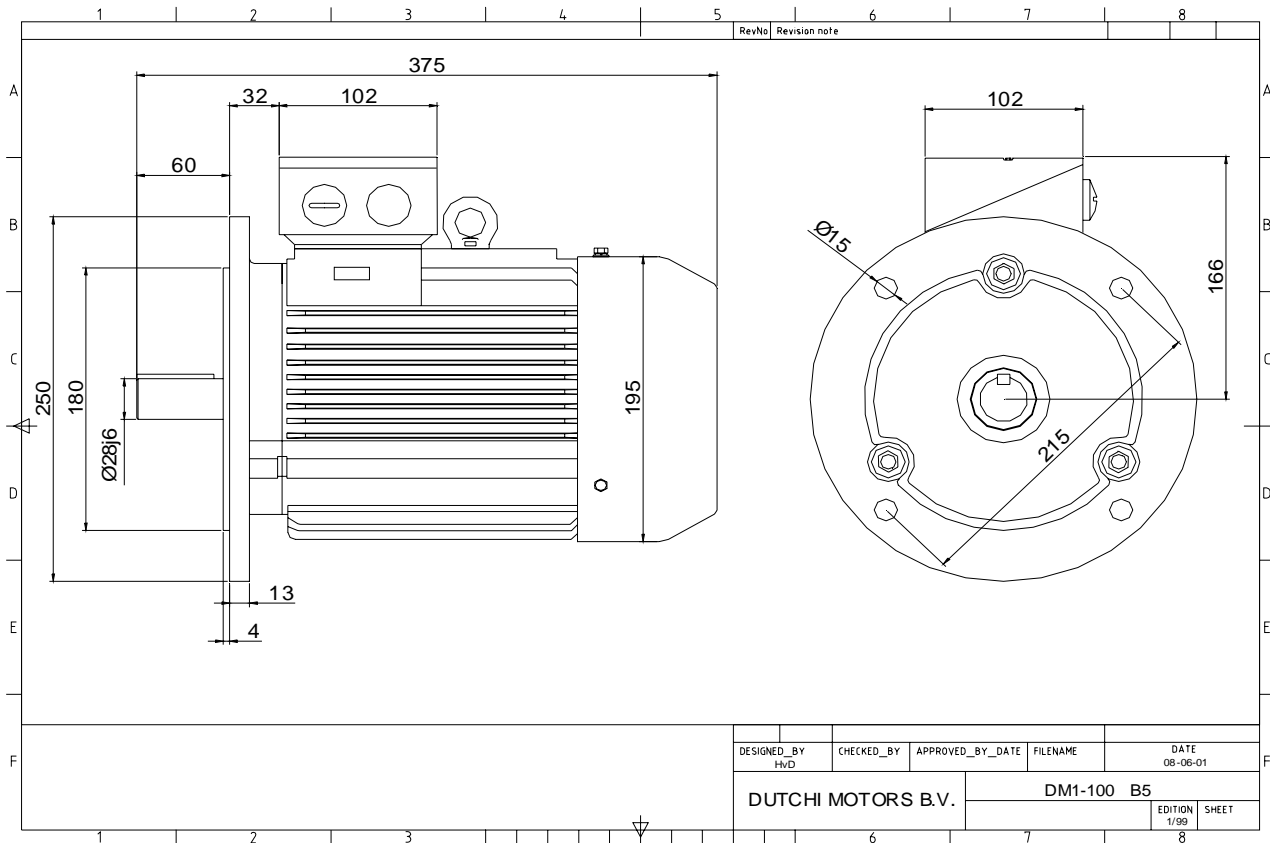

Specification	<b>IEC 60034-1</b>
Manufacturer	<b>Dutchi Motors B.V.</b>
Motor type	<b>DM1- 100 L2</b>
Rated power	<b>3</b> kW <b>S1</b> duty
Speed	<b>2850</b> r.p.m
Voltage	<b>230 / 400</b> V
Frequency	<b>50</b> Hz
Connection	<b>Δ / Y</b>
Amps full load	<b>10,28 / 5,93</b> A
Amps no-load(400V)	<b>2,40</b> A
Enclosure	<b>IP 55</b>
Insulation Class	<b>F (temp. rise B (80 K))</b>
Max. coolant temp.	<b>40°C</b>
Max. altitude	<b>1.000</b> mtr, above sea level
Comment	<b>3 x PTC 150°C</b>
Cable entries	<b>2 x M25x1,5 + 1 x M20x1,5 (ptc)</b>
Feature	<b>Cast-iron motor</b>
Weight	<b>33,0</b> kg
Catalog no.	<b>11222300D</b>
Warranty	<b>12~18 months</b>

Efficiency class	<b>EFF 2</b>
Load data	100% 75% 50% 25%
Efficiency	<b>82,6 82,5 80,2 71,3</b> %
Power factor	<b>0,88 0,84 0,75 0,56</b>
Sound pressure level (1m)	<b>64,0</b> dB(A)
Resistance R20 (open)	<b>1,80</b> Ω
Resistance R20	<b>Y 3,60</b> Ω
Full load torque	<b>10,05</b> Nm
DOL Starting torque vs FL torque	<b>2,91</b>
DOL Pull up torque vs FL torque	<b>1,96</b>
DOL Pull out torque vs FL torque	<b>3,25</b>
Star-Delta Starting torque vs FL torque	<b>Y - motor</b>
Star-Delta Pull up torque vs FL torque	<b>Y - motor</b>
Star-Delta Pull out torque vs FL torque	<b>Y - motor</b>
DOL Starting current vs FL current	<b>7,58</b>
Star Delta Starting current vs FL current	<b>Y - motor</b>
Rotor Inertia	<b>0,0029</b> kgm <sup>2</sup>
Bearing DE	<b>6206 - ZZ C3</b>
Bearing NDE	<b>6206 - ZZ C3</b>

WI	Change	date	sign.
<b>Dutchi Motors B.V.</b> P.O. Box 5390 NL-6802 EJ ARNHEM Tel : +31-(0)26 - 3541 600 Fax : +31-(0)26 - 3541 650		Discription Drawing made by :	date 19-04-04 sign. HvD
dutchi.motors@dutchi.nl www.dutchi.com			

Power is our commodity, the world is our market !

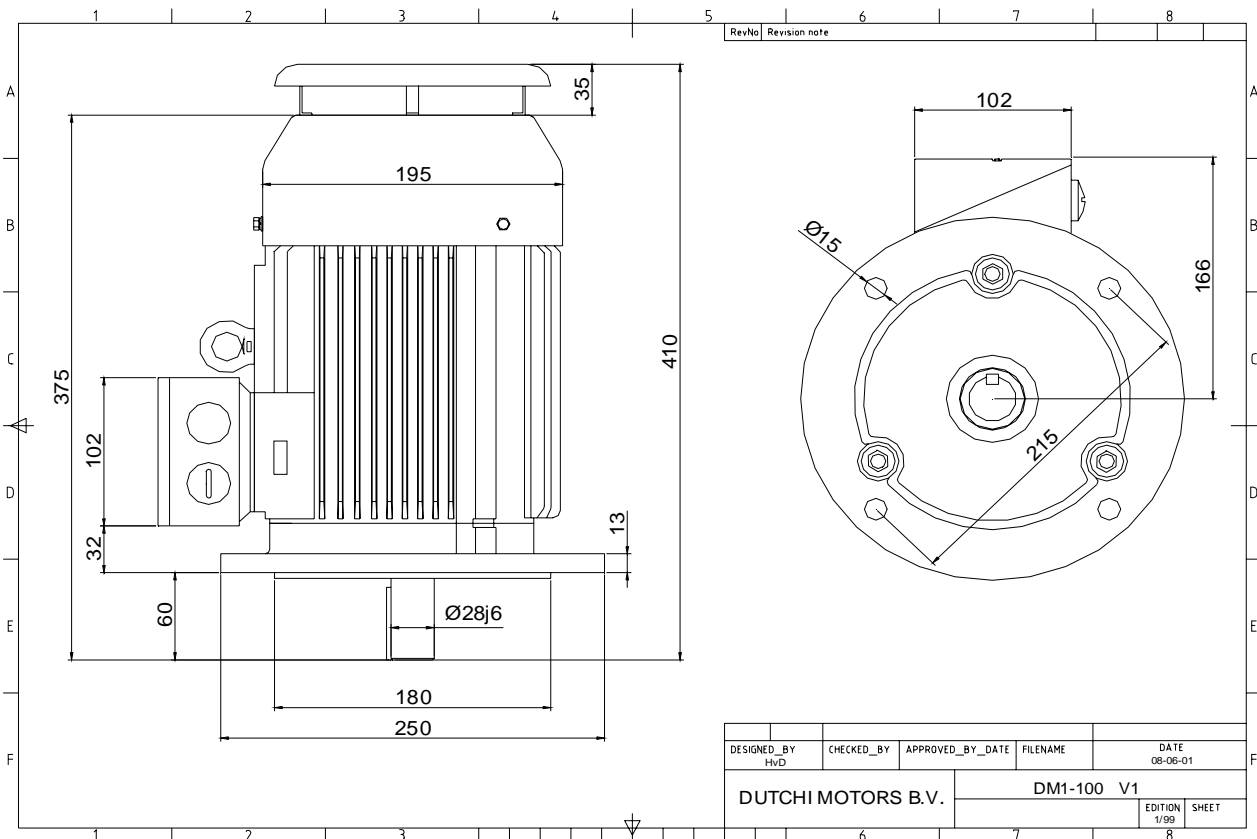

Specification **IEC 60034-1**  
 Manufacturer **Dutchi Motors B.V.**  
 Motor type **DM1- 100 L2**  
 Rated power **3** kW **S1** duty  
 Speed **2850** r.p.m  
 Voltage **230 / 400** V  
 Frequency **50** Hz  
 Connection **Δ / Y**  
 Amps full load **10,28 / 5,93** A  
 Amps no-load(400V) **2,40** A  
 Enclosure **IP 55**  
 Insulation Class **F (temp. rise B (80 K))**

Max. coolant temp. **40°C**  
 Max. altitude **1.000** mtr, above sea level  
 Comment **3 x PTC 150°C**  
 Cable entries **2 x M25x1,5 + 1 x M20x1,5 (ptc)**

Feature **Cast-iron motor**  
 Weight **33,0** kg  
 Catalog no. **11022300D**  
 Warranty **12~18 months**

Efficiency class **EFF 2**  
 Load data 100% 75% 50% 25%  
 Efficiency **82,6 82,5 80,2 71,3** %  
 Power factor **0,88 0,84 0,75 0,56**

Sound pressure level (1m) **64,0** dB(A)  
 Resistance R20 (open) **1,80** Ω  
 Resistance R20 **Y 3,60** Ω

Full load torque **10,05** Nm  
 DOL Starting torque vs FL torque **2,91**  
 DOL Pull up torque vs FL torque **1,96**  
 DOL Pull out torque vs FL torque **3,25**  
 Star-Delta Starting torque vs FL torque **Y - motor**  
 Star-Delta Pull up torque vs FL torque **Y - motor**  
 Star-Delta Pull out torque vs FL torque **Y - motor**  
 DOL Starting current vs FL current **7,58**  
 Star Delta Starting current vs FL current **Y - motor**  
 Rotor Inertia **0,0029** kgm<sup>2</sup>

Bearing DE **6206 - ZZ C3**  
 Bearing NDE **6206 - ZZ C3**

WI	Change	date	sign.
<b>Dutchi Motors B.V.</b> P.O. Box 5390 NL-6802 EJ ARNHEM Tel : +31-(0)26 - 3541 600 Fax : +31-(0)26 - 3541 650		Description	date
		Drawing made by :	19-04-04
		<b>dutchi.motors@dutchi.nl</b> <b>www.dutchi.com</b>	

Power is our commodity, the world is our market !

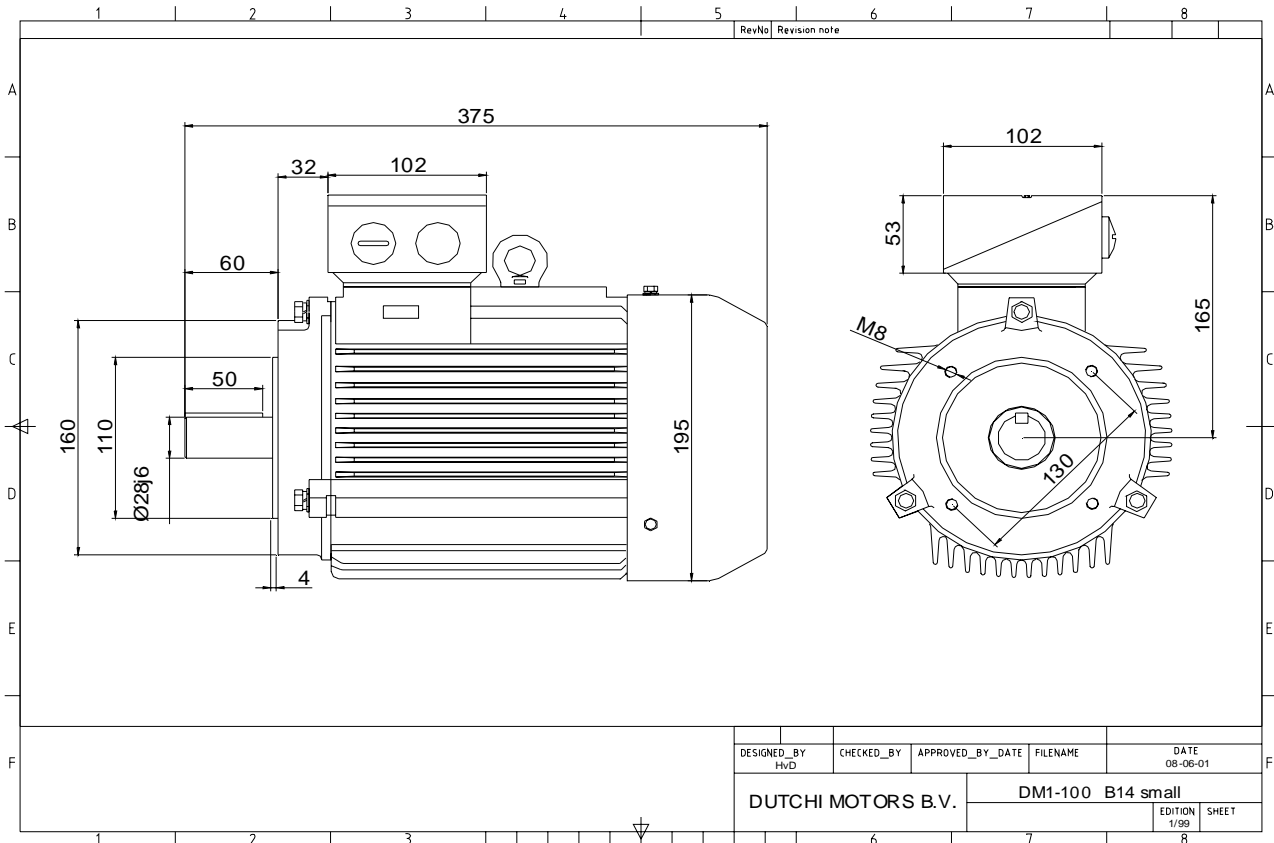

Specification **IEC 60034-1**  
 Manufacturer **Dutchi Motors B.V.**  
 Motor type **DM1- 100 L2**  
 Rated power **3** kW **S1** duty  
 Speed **2850** r.p.m  
 Voltage **230 / 400** V  
 Frequency **50** Hz  
 Connection **Δ / Y**  
 Amps full load **10,28 / 5,93** A  
 Amps no-load(400V) **2,40** A  
 Enclosure **IP 55**  
 Insulation Class **F (temp. rise B (80 K))**

Max. coolant temp. **40°C**  
 Max. altitude **1.000** mtr, above sea level  
 Comment **3 x PTC 150°C**  
 Cable entries **2 x M25x1,5 + 1 x M20x1,5 (ptc)**

Feature **Cast-iron motor**  
 Weight **33,0** kg  
 Catalog no. **11322300D**  
 Warranty **12~18 months**

Efficiency class **EFF 2**  
 Load data 100% 75% 50% 25%  
 Efficiency **82,6 82,5 80,2 71,3** %  
 Power factor **0,88 0,84 0,75 0,56**

Sound pressure level (1m) **64,0** dB(A)  
 Resistance R20 (open) **1,80** Ω  
 Resistance R20 **Y 3,60** Ω

Full load torque **10,05** Nm  
 DOL Starting torque vs FL torque **2,91**  
 DOL Pull up torque vs FL torque **1,96**  
 DOL Pull out torque vs FL torque **3,25**  
 Star-Delta Starting torque vs FL torque **Y - motor**  
 Star-Delta Pull up torque vs FL torque **Y - motor**  
 Star-Delta Pull out torque vs FL torque **Y - motor**  
 DOL Starting current vs FL current **7,58**  
 Star Delta Starting current vs FL current **Y - motor**  
 Rotor Inertia **0,0029** kgm<sup>2</sup>

Bearing DE **6206 - ZZ C3**  
 Bearing NDE **6206 - ZZ C3**

WI	Change	date	sign.
<b>Dutchi Motors B.V.</b> P.O. Box 5390 NL-6802 EJ ARNHEM Tel : +31-(0)26 - 3541 600 Fax : +31-(0)26 - 3541 650		Description	date
		Drawing made by :	19-04-04
		<b>dutchi.motors@dutchi.nl</b> <b>www.dutchi.com</b>	

Power is our commodity, the world is our market !

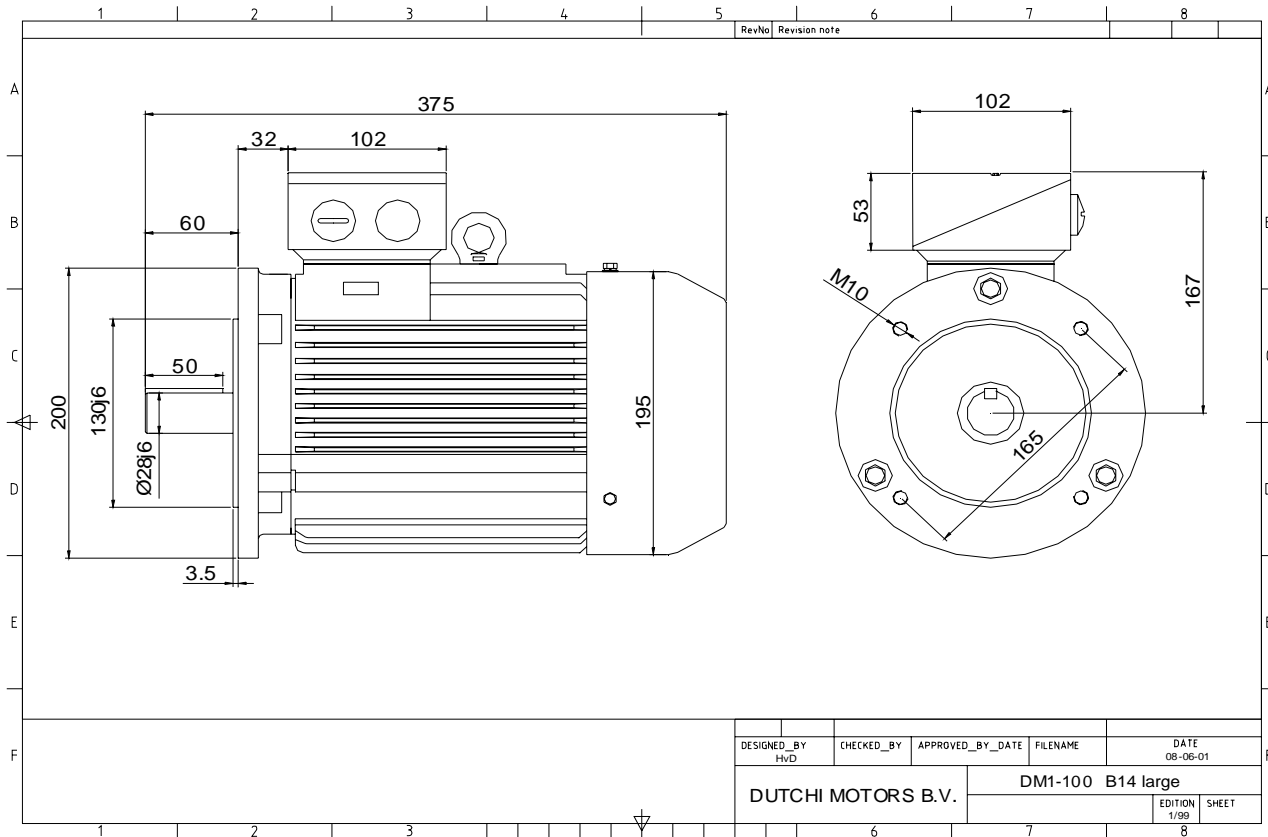

Specification **IEC 60034-1**  
 Manufacturer **Dutchi Motors B.V.**  
 Motor type **DM1- 100 L2**  
 Rated power **3** kW **S1** duty  
 Speed **2850** r.p.m  
 Voltage **230 / 400** V  
 Frequency **50** Hz  
 Connection **Δ / Y**  
 Amps full load **10,28 / 5,93** A  
 Amps no-load(400V) **2,40** A  
 Enclosure **IP 55**  
 Insulation Class **F (temp. rise B (80 K))**

Max. coolant temp. **40°C**  
 Max. altitude **1.000** mtr, above sea level  
 Comment **3 x PTC 150°C**  
 Cable entries **2 x M25x1,5 + 1 x M20x1,5 (ptc)**

Feature **Cast-iron motor**  
 Weight **33,0** kg  
 Catalog no. **11422300D**  
 Warranty **12~18 months**

Efficiency class **EFF 2**  
 Load data 100% 75% 50% 25%  
 Efficiency **82,6 82,5 80,2 71,3** %  
 Power factor **0,88 0,84 0,75 0,56**

Sound pressure level (1m) **64,0** dB(A)  
 Resistance R20 (open) **1,80** Ω  
 Resistance R20 **Y 3,60** Ω

Full load torque **10,05** Nm  
 DOL Starting torque vs FL torque **2,91**  
 DOL Pull up torque vs FL torque **1,96**  
 DOL Pull out torque vs FL torque **3,25**  
 Star-Delta Starting torque vs FL torque **Y - motor**  
 Star-Delta Pull up torque vs FL torque **Y - motor**  
 Star-Delta Pull out torque vs FL torque **Y - motor**  
 DOL Starting current vs FL current **7,58**  
 Star Delta Starting current vs FL current **Y - motor**  
 Rotor Inertia **0,0029** kgm<sup>2</sup>

Bearing DE **6206 - ZZ C3**  
 Bearing NDE **6206 - ZZ C3**

WI	Change	date	sign.
Dutchi Motors B.V.		Description	date
P.O. Box 5390		Drawing made by :	19-04-04
NL-6802 EJ ARNHEM			HvD
Tel : +31-(0)26 - 3541 600		dutchi.motors@dutchi.nl	
Fax : +31-(0)26 - 3541 650		www.dutchi.com	