

Power is our commodity, the world is our market !

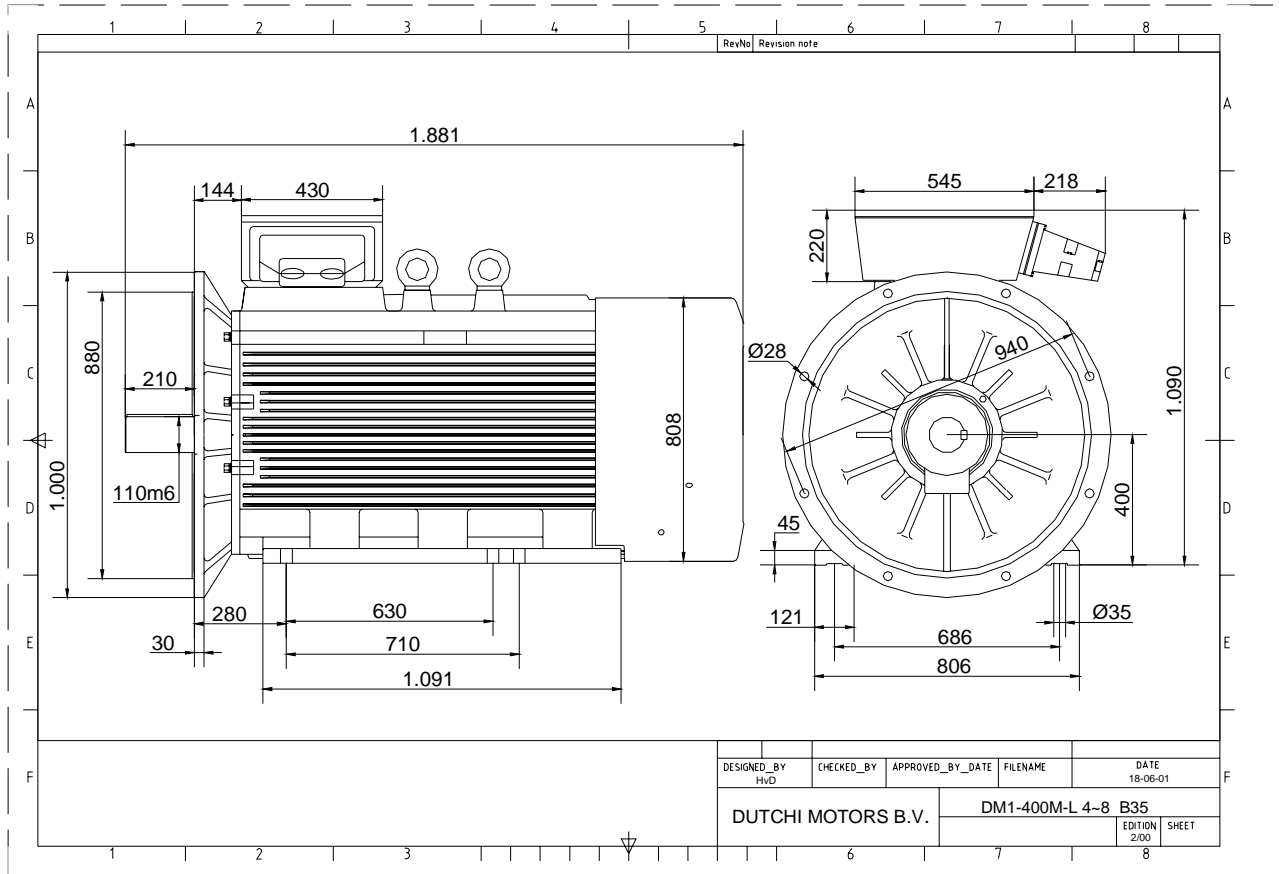

Specification	IEC 60034-1
Manufacturer	Dutchi Motors B.V.
Motor type	DM1- 400 M4
Rated power	400 kW S1 duty
Speed	1490 r.p.m
Voltage	400 / 690 V
Frequency	50 Hz
Connection	Δ / Y
Amps full load	682 / 394 A
Amps no-load(400V)	196 A
Enclosure	IP 55
Insulation Class	F (temp. rise B (80 K))
Max. coolant temp.	40°C
Max. altitude	1.000 mtr, above sea level
Comment	3 x PTC 150°C
Cable entries	2 x Ø 100 mm + 1 x M20x1,5 (ptc)
Feature	Cast-iron motor
Weight	3000 kg
Catalog no.	11534E00D
Warranty	12~18 months

Efficiency class	N/A			
Load data	100%	75%	50%	25%
Efficiency	95,8	95,5	94,4	90,5 %
Power factor	0,88	0,86	0,79	0,59
Sound pressure level (1m)	90,0 dB(A)			
Resistance R20 (open)	0,00410 Ω			
Resistance R20	Δ 0,00273 Ω			
Full load torque	2564 Nm			
DOL Starting torque vs FL torque	1,33			
DOL Pull up torque vs FL torque	1,31			
DOL Pull out torque vs FL torque	3,58			
Star-Delta Starting torque vs FL torque	0,42			
Star-Delta Pull up torque vs FL torque	0,41			
Star-Delta Pull out torque vs FL torque	1,12			
DOL Starting current vs FL current	6,17			
Star Delta Starting current vs FL current	1,93			
Rotor Inertia	14,90 kgm ²			
Bearing DE	6326 - C3 or NU326			
Bearing NDE	6326 - C3 (IM V1 7326B)			

Extras / Options :
Terminal box with extra 7 x M63x1,5

WI	Change	date	sign.
Dutchi Motors B.V.		Discription	date
P.O. Box 5390		Drawing made by :	19-04-04
NL-6802 EJ ARNHEM			
Tel : +31-(0)26 - 3541 600		dutchi.motors@dutchi.nl	
Fax : +31-(0)26 - 3541 650		www.dutchi.com	

Power is our commodity, the world is our market !

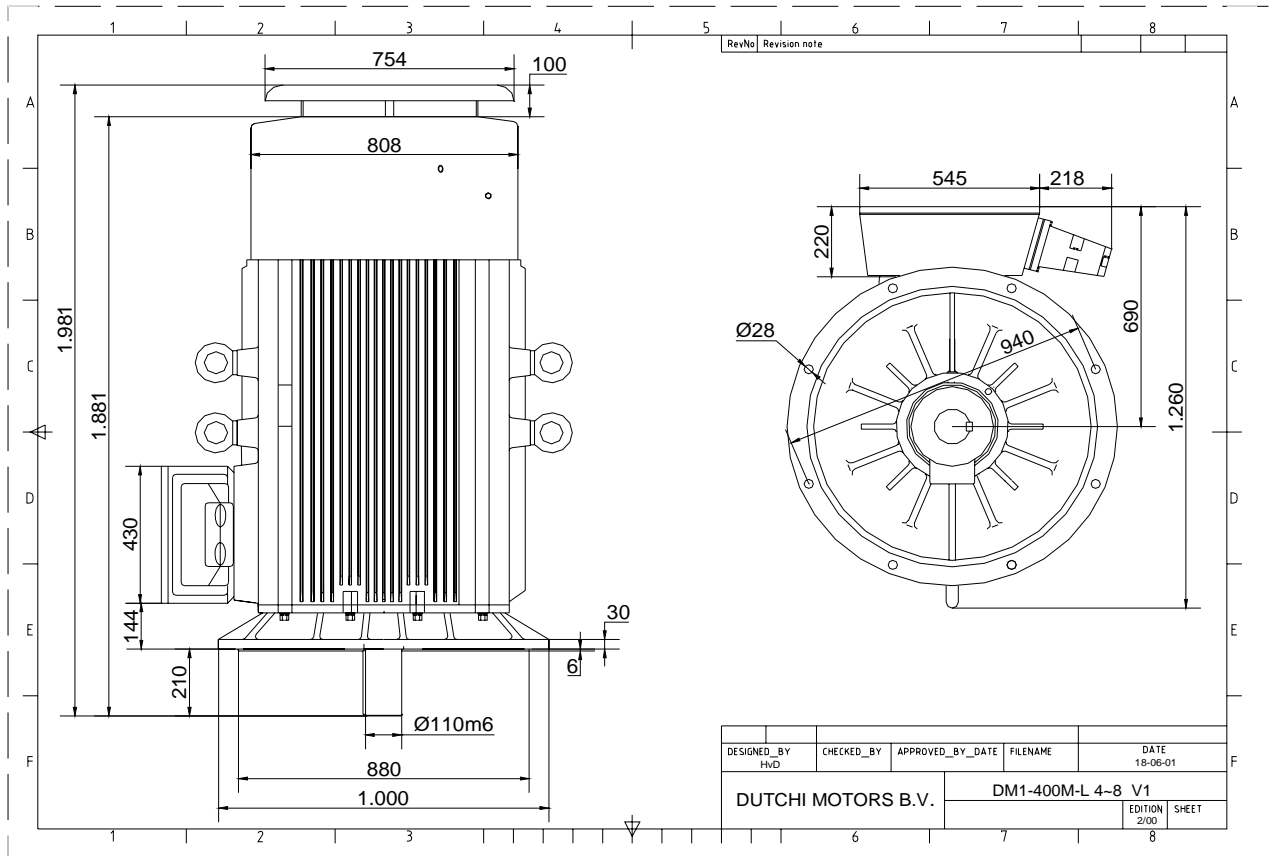

Specification	IEC 60034-1
Manufacturer	Dutchi Motors B.V.
Motor type	DM1- 400 M4
Rated power	400 kW S1 duty
Speed	1490 r.p.m
Voltage	400 / 690 V
Frequency	50 Hz
Connection	Δ / Y
Amps full load	682 / 394 A
Amps no-load(400V)	196 A
Enclosure	IP 55
Insulation Class	F (temp. rise B (80 K))
Max. coolant temp.	40°C
Max. altitude	1.000 mtr, above sea level
Comment	3 x PTC 150°C
Cable entries	2 x Ø 100 mm + 1 x M20x1,5 (ptc)
Feature	Cast-iron motor
Weight	3000 kg
Catalog no.	11034E00D
Warranty	12~18 months

Efficiency class	N/A			
Load data	100%	75%	50%	25%
Efficiency	95,8	95,5	94,4	90,5 %
Power factor	0,88	0,86	0,79	0,59
Sound pressure level (1m)				90,0 dB(A)
Resistance R20 (open)				0,00410 Ω
Resistance R20	Δ			0,00273 Ω
Full load torque				2564 Nm
DOL Starting torque vs FL torque				1,33
DOL Pull up torque vs FL torque				1,31
DOL Pull out torque vs FL torque				3,58
Star-Delta Starting torque vs FL torque				0,42
Star-Delta Pull up torque vs FL torque				0,41
Star-Delta Pull out torque vs FL torque				1,12
DOL Starting current vs FL current				6,17
Star Delta Starting current vs FL current				1,93
Rotor Inertia				14,90 kgm ²
Bearing DE				6326 - C3 or NU326
Bearing NDE				6326 - C3 (IM V1 7326B)

Extras / Options :
Terminal box with extra 7 x M63x1,5

WI	Change	date	sign.
Dutchi Motors B.V.		Discription	date
P.O. Box 5390		Drawing made by :	19-04-04
NL-6802 EJ ARNHEM			
Tel : +31-(0)26 - 3541 600		dutchi.motors@dutchi.nl	
Fax : +31-(0)26 - 3541 650		www.dutchi.com	