

Power is our commodity, the world is our market !

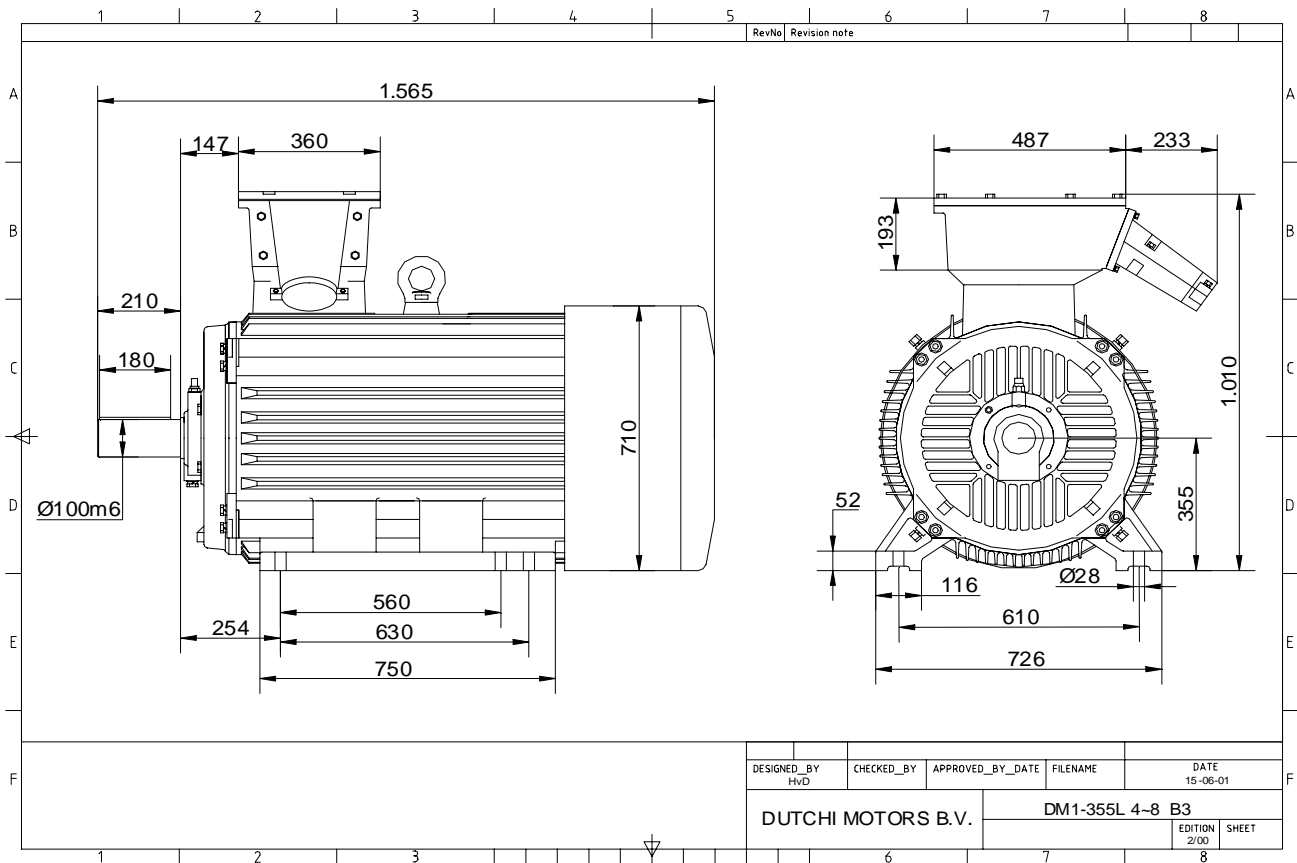

Specification	IEC 60034-1
Manufacturer	Dutchi Motors B.V.
Motor type	DM1- 355 L4
Rated power	280 kW S1 duty
Speed	1490 r.p.m
Voltage	400 / 690 V
Frequency	50 Hz
Connection	Δ / Y
Amps full load	462 / 267 A
Amps no-load(400V)	95 A
Enclosure	IP 55
Insulation Class	F (temp. rise B (80 K))
Max. coolant temp.	40°C
Max. altitude	1.000 mtr, above sea level
Comment	3 x PTC 150°C
Cable entries	2 x Ø 70 mm + 1 x M20x1,5 (ptc)
Feature	Cast-iron motor
Weight	1830 kg
Catalog no.	11134C80D
Warranty	12~18 months

Efficiency class	N/A			
Load data	100%	75%	50%	25%
Efficiency	95,7	95,5	94,5	91,0 %
Power factor	0,91	0,91	0,89	0,77
Sound pressure level (1m)				78,9 dB(A)
Resistance R20 (open)				0,00937 Ω
Resistance R20	Δ			0,00624 Ω
Full load torque				1795 Nm
DOL Starting torque vs FL torque				2,04
DOL Pull up torque vs FL torque				1,46
DOL Pull out torque vs FL torque				2,78
Star-Delta Starting torque vs FL torque				0,64
Star-Delta Pull up torque vs FL torque				0,46
Star-Delta Pull out torque vs FL torque				0,87
DOL Starting current vs FL current				6,47
Star Delta Starting current vs FL current				2,02
Rotor Inertia				8,70 kgm ²
Bearing DE				6322 - C3 or NU322
Bearing NDE				6317 - C3 (IM V1 7317B)

WI	Change	date	sign.
Dutchi Motors B.V. P.O. Box 5390 NL-6802 EJ ARNHEM Tel : +31-(0)26 - 3541 600 Fax : +31-(0)26 - 3541 650		Discription Drawing made by :	date 27-04-04 sign. HvD
		dutchi.motors@dutchi.nl www.dutchi.com	

Power is our commodity, the world is our market !

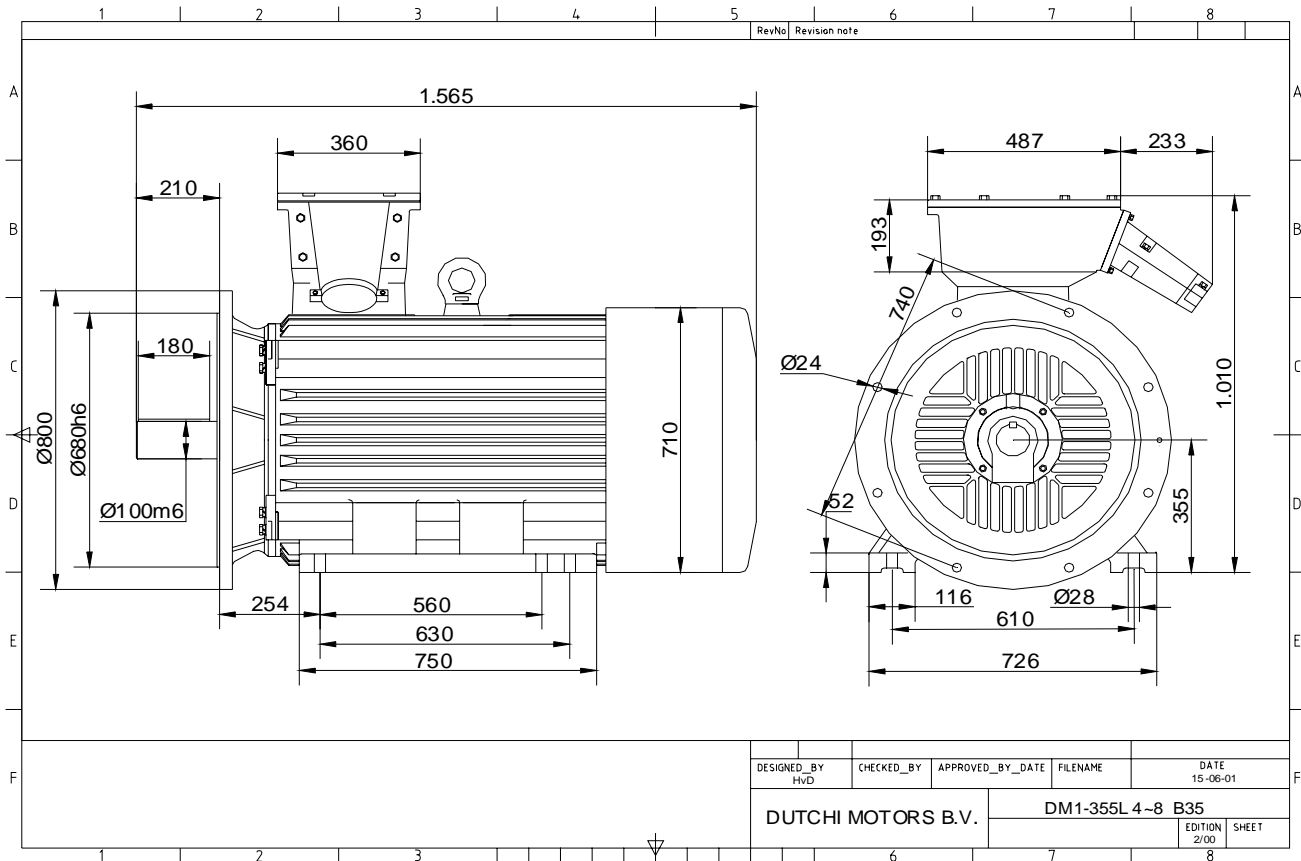

Specification **IEC 60034-1**
 Manufacturer **Dutchi Motors B.V.**
 Motor type **DM1- 355 L4**
 Rated power **280** kW **S1** duty
 Speed **1490** r.p.m
 Voltage **400** / **690** V
 Frequency **50** Hz
 Connection **Δ** / **Y**
 Amps full load **462** / **267** A
 Amps no-load(400V) **95** A
 Enclosure **IP 55**
 Insulation Class **F (temp. rise B (80 K))**

Max. coolant temp. **40°C**
 Max. altitude **1.000** mtr, above sea level
 Comment **3 x PTC 150°C**
 Cable entries **2 x Ø 70 mm + 1 x M20x1,5 (ptc)**

Feature **Cast-iron motor**
 Weight **1830** kg
 Catalog no. **11534C80D**
 Warranty **12~18 months**

Efficiency class **N/A**
 Load data 100% 75% 50% 25%
 Efficiency **95,7 95,5 94,5 91,0** %
 Power factor **0,91 0,91 0,89 0,77**

Sound pressure level (1m) **78,9** dB(A)
 Resistance R20 (open) **0,00937** Ω
 Resistance R20 **Δ 0,00624** Ω

Full load torque **1795** Nm
 DOL Starting torque vs FL torque **2,04**
 DOL Pull up torque vs FL torque **1,46**
 DOL Pull out torque vs FL torque **2,78**
 Star-Delta Starting torque vs FL torque **0,64**
 Star-Delta Pull up torque vs FL torque **0,46**
 Star-Delta Pull out torque vs FL torque **0,87**
 DOL Starting current vs FL current **6,47**
 Star Delta Starting current vs FL current **2,02**
 Rotor Inertia **8,70** kgm²

Bearing DE **6322 - C3 or NU322**
 Bearing NDE **6317 - C3 (IM V1 7317B)**

WI	Change	date	sign.
Dutchi Motors B.V. P.O. Box 5390 NL-6802 EJ ARNHEM Tel : +31-(0)26 - 3541 600 Fax : +31-(0)26 - 3541 650		Discription	date
		Drawing made by :	27-04-04
		dutchi.motors@dutchi.nl www.dutchi.com	

Power is our commodity, the world is our market !

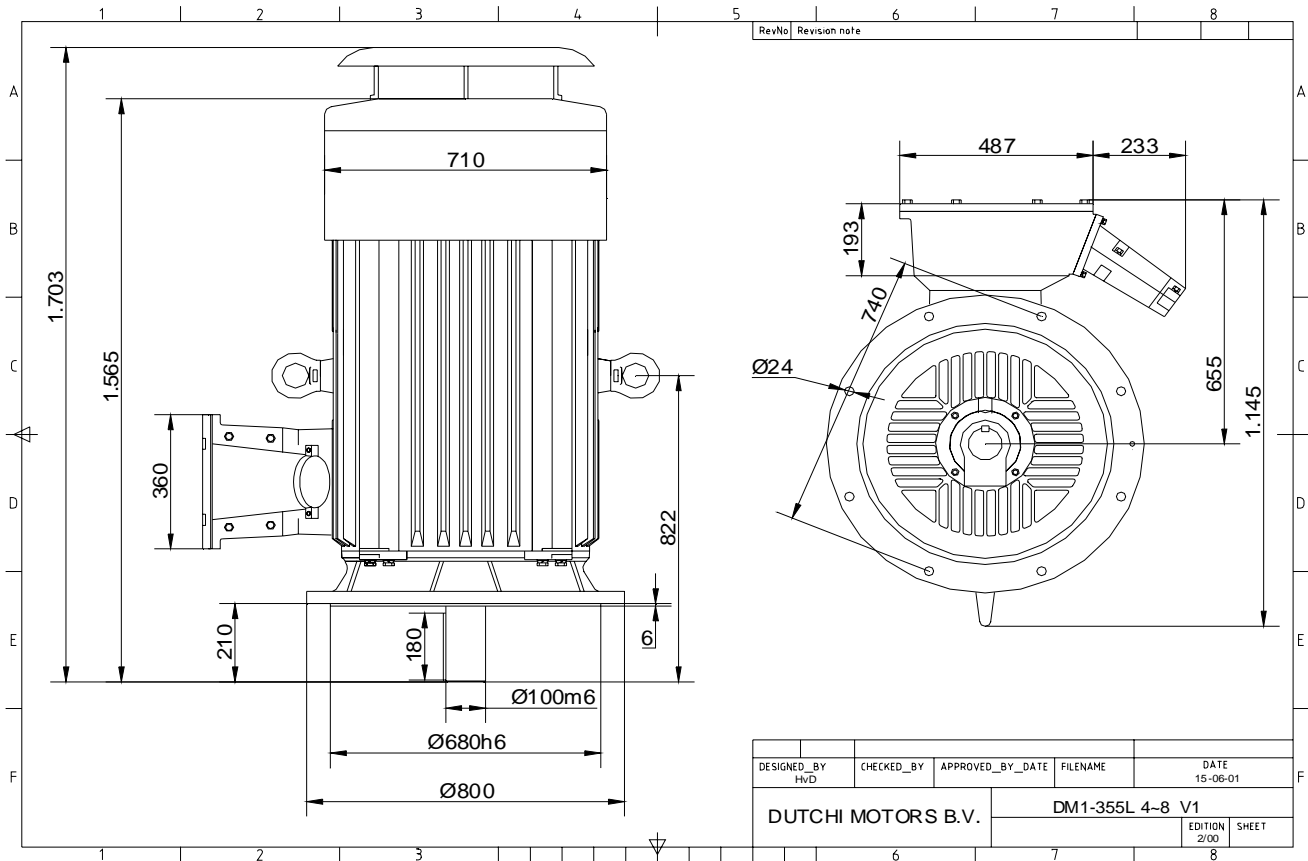

Specification **IEC 60034-1**
 Manufacturer **Dutchi Motors B.V.**
 Motor type **DM1- 355 L4**
 Rated power **280** kW **S1** duty
 Speed **1490** r.p.m
 Voltage **400 / 690** V
 Frequency **50** Hz
 Connection **Δ / Y**
 Amps full load **462 / 267** A
 Amps no-load(400V) **95** A
 Enclosure **IP 55**
 Insulation Class **F (temp. rise B (80 K))**

Max. coolant temp. **40°C**
 Max. altitude **1.000** mtr, above sea level
 Comment **3 x PTC 150°C**
 Cable entries **2 x Ø 70 mm + 1 x M20x1,5 (ptc)**

Feature **Cast-iron motor**
 Weight **1830** kg
 Catalog no. **11034C80D**
 Warranty **12~18 months**

Efficiency class **N/A**
 Load data 100% 75% 50% 25%
 Efficiency **95,7 95,5 94,5 91,0** %
 Power factor **0,91 0,91 0,89 0,77**

Sound pressure level (1m) **78,9** dB(A)
 Resistance R20 (open) **0,00937** Ω
 Resistance R20 **Δ 0,00624** Ω

Full load torque **1795** Nm
 DOL Starting torque vs FL torque **2,04**
 DOL Pull up torque vs FL torque **1,46**
 DOL Pull out torque vs FL torque **2,78**
 Star-Delta Starting torque vs FL torque **0,64**
 Star-Delta Pull up torque vs FL torque **0,46**
 Star-Delta Pull out torque vs FL torque **0,87**
 DOL Starting current vs FL current **6,47**
 Star Delta Starting current vs FL current **2,02**
 Rotor Inertia **8,70** kgm²

Bearing DE **6322 - C3 or NU322**
 Bearing NDE **6317 - C3 (IM V1 7317B)**

WI	Change	date	sign.
Dutchi Motors B.V.		Description	date
P.O. Box 5390		Drawing made by :	27-04-04
NL-6802 EJ ARNHEM			
Tel : +31-(0)26 - 3541 600		dutchi.motors@dutchi.nl	
Fax : +31-(0)26 - 3541 650		www.dutchi.com	