

Power is our commodity, the world is our market !

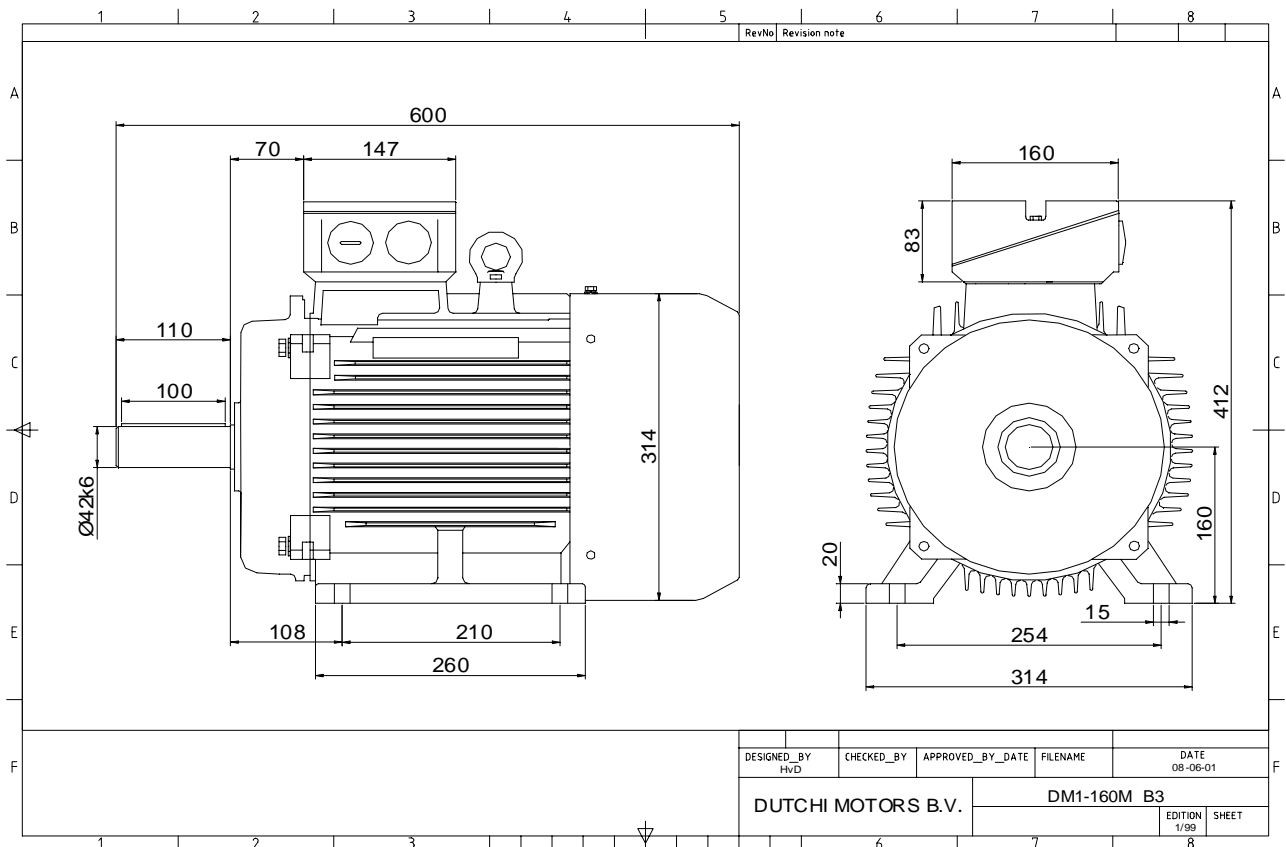

Specification **IEC 60034-1**
 Manufacturer **Dutchi Motors B.V.**
 Motor type **DM1- 160 M4**
 Rated power **11,00 kW S1** duty
 Speed **1460** r.p.m
 Voltage **400 / 690** V
 Frequency **50** Hz
 Connection **Δ / Y**
 Amps full load **21,40 / 12,35** A
 Amps no-load(400V) **8,02** A
 Enclosure **IP 55**
 Insulation Class **F (temp. rise B (80 K))**

Max. coolant temp. **40°C**
 Max. altitude **1.000** mtr, above sea level
 Comment **3 x PTC 150°C**
 Cable entries **2 x M40x1,5 + 1 x M20x1,5 (ptc)**

Feature **Cast-iron motor**
 Weight **113** kg
 Catalog no. **11134A11D**
 Warranty **12~18 months**

Efficiency class **EFF 2**
 Load data 100% 75% 50% 25%
 Efficiency **88,5 89,2 88,3 83,0** %
 Power factor **0,84 0,81 0,71 0,52**

Sound pressure level (1m) **67,2** dB(A)
 Resistance R20 (open) **0,915** Ω
 Resistance R20 **Δ 0,610** Ω

Full load torque **71,95** Nm
 DOL Starting torque vs FL torque **2,04**
 DOL Pull up torque vs FL torque **1,45**
 DOL Pull out torque vs FL torque **2,68**
 Star-Delta Starting torque vs FL torque **0,64**
 Star-Delta Pull up torque vs FL torque **0,45**
 Star-Delta Pull out torque vs FL torque **0,84**
 DOL Starting current vs FL current **6,20**
 Star Delta Starting current vs FL current **1,94**
 Rotor Inertia **0,0724** kgm²

Bearing DE **6309 - ZZ C3**
 Bearing NDE **6309 - ZZ C3**

WI	Change	date	sign.
Dutchi Motors B.V.		Description	date
P.O. Box 5390		Drawing made by :	27-04-04
NL-6802 EJ ARNHEM			
Tel : +31-(0)26 - 3541 600		dutchi.motors@dutchi.nl	
Fax : +31-(0)26 - 3541 650		www.dutchi.com	

Power is our commodity, the world is our market !

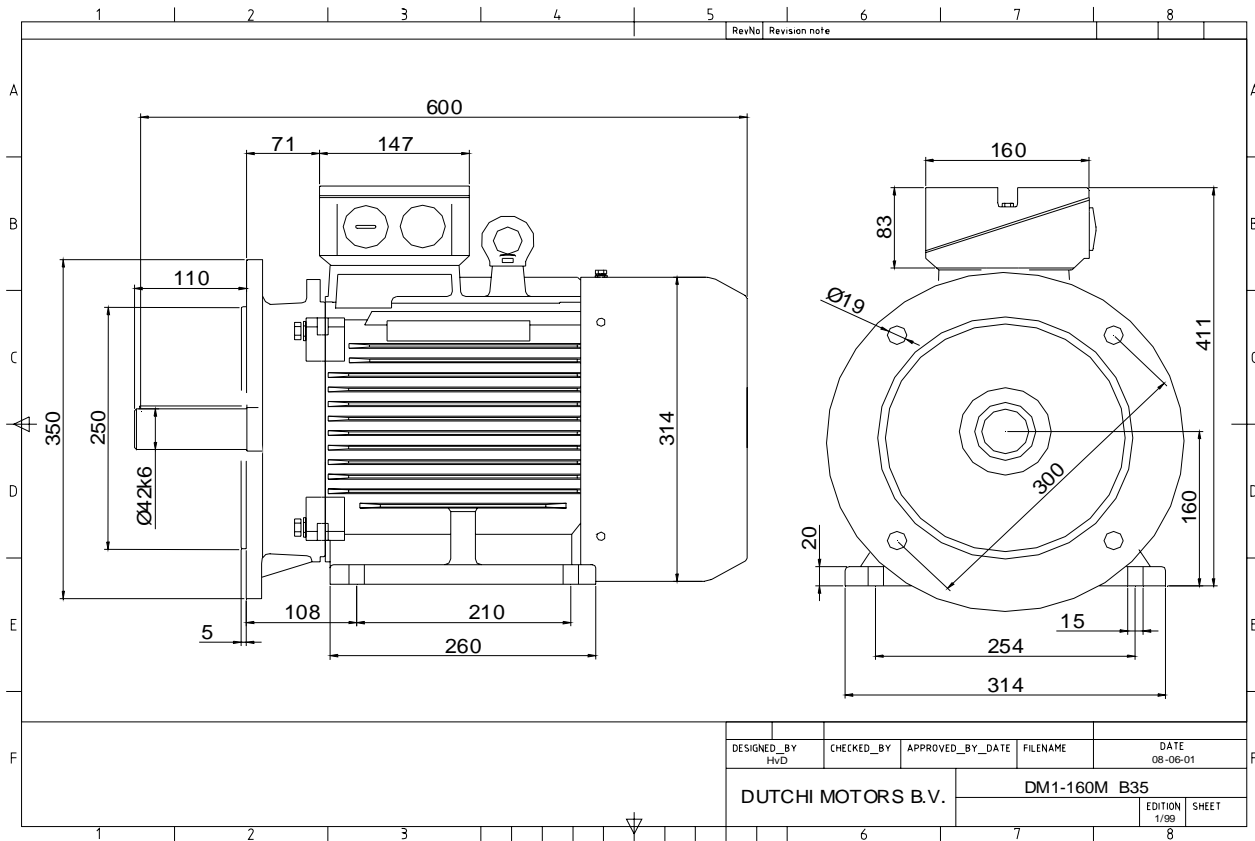

Specification **IEC 60034-1**
 Manufacturer **Dutchi Motors B.V.**
 Motor type **DM1- 160 M4**
 Rated power **11,00 kW S1** duty
 Speed **1460** r.p.m
 Voltage **400 / 690** V
 Frequency **50** Hz
 Connection **Δ / Y**
 Amps full load **21,40 / 12,35** A
 Amps no-load(400V) **8,02** A
 Enclosure **IP 55**
 Insulation Class **F (temp. rise B (80 K))**

Max. coolant temp. **40°C**
 Max. altitude **1.000** mtr, above sea level
 Comment **3 x PTC 150°C**
 Cable entries **2 x M40x1,5 + 1 x M20x1,5 (ptc)**

Feature **Cast-iron motor**
 Weight **113** kg
 Catalog no. **11534A11D**
 Warranty **12~18 months**

Efficiency class **EFF 2**
 Load data 100% 75% 50% 25%
 Efficiency **88,5 89,2 88,3 83,0** %
 Power factor **0,84 0,81 0,71 0,52**

Sound pressure level (1m) **67,2** dB(A)
 Resistance R20 (open) **0,915** Ω
 Resistance R20 **Δ 0,610** Ω

Full load torque **71,95** Nm
 DOL Starting torque vs FL torque **2,04**
 DOL Pull up torque vs FL torque **1,45**
 DOL Pull out torque vs FL torque **2,68**
 Star-Delta Starting torque vs FL torque **0,64**
 Star-Delta Pull up torque vs FL torque **0,45**
 Star-Delta Pull out torque vs FL torque **0,84**
 DOL Starting current vs FL current **6,20**
 Star Delta Starting current vs FL current **1,94**
 Rotor Inertia **0,0724** kgm²

Bearing DE **6309 - ZZ C3**
 Bearing NDE **6309 - ZZ C3**

WI	Change	date	sign.
Dutchi Motors B.V. P.O. Box 5390 NL-6802 EJ ARNHEM Tel : +31-(0)26 - 3541 600 Fax : +31-(0)26 - 3541 650		Discription Drawing made by :	date 27-04-04 sign. HVD
		dutchi.motors@dutchi.nl www.dutchi.com	

Power is our commodity, the world is our market !

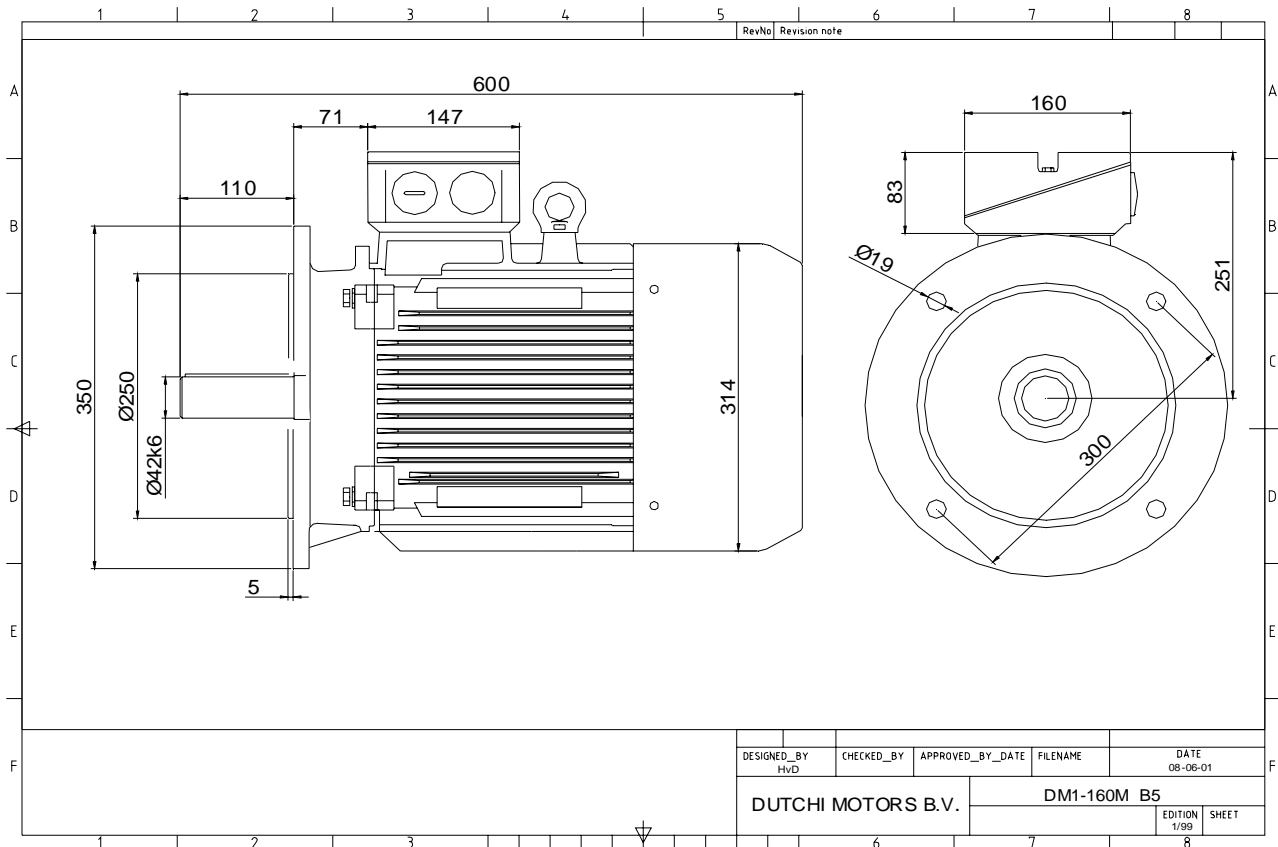

Specification **IEC 60034-1**
 Manufacturer **Dutchi Motors B.V.**
 Motor type **DM1- 160 M4**
 Rated power **11,00 kW S1** duty
 Speed **1460** r.p.m
 Voltage **400 / 690** V
 Frequency **50** Hz
 Connection **Δ / Y**
 Amps full load **21,40 / 12,35** A
 Amps no-load(400V) **8,02** A
 Enclosure **IP 55**
 Insulation Class **F (temp. rise B (80 K))**

Max. coolant temp. **40°C**
 Max. altitude **1.000** mtr, above sea level
 Comment **3 x PTC 150°C**
 Cable entries **2 x M40x1,5 + 1 x M20x1,5 (ptc)**

Feature **Cast-iron motor**
 Weight **113** kg
 Catalog no. **11234A11D**
 Warranty **12~18 months**

Efficiency class **EFF 2**
 Load data 100% 75% 50% 25%
 Efficiency **88,5 89,2 88,3 83,0** %
 Power factor **0,84 0,81 0,71 0,52**

Sound pressure level (1m) **67,2** dB(A)
 Resistance R20 (open) **0,915** Ω
 Resistance R20 **Δ 0,610** Ω

Full load torque **71,95** Nm
 DOL Starting torque vs FL torque **2,04**
 DOL Pull up torque vs FL torque **1,45**
 DOL Pull out torque vs FL torque **2,68**
 Star-Delta Starting torque vs FL torque **0,64**
 Star-Delta Pull up torque vs FL torque **0,45**
 Star-Delta Pull out torque vs FL torque **0,84**
 DOL Starting current vs FL current **6,20**
 Star Delta Starting current vs FL current **1,94**
 Rotor Inertia **0,0724** kgm²

Bearing DE **6309 - ZZ C3**
 Bearing NDE **6309 - ZZ C3**

WI	Change	date	sign.
Dutchi Motors B.V.		Description	date
P.O. Box 5390		Drawing made by :	27-04-04
NL-6802 EJ ARNHEM			
Tel : +31-(0)26 - 3541 600		dutchi.motors@dutchi.nl	
Fax : +31-(0)26 - 3541 650		www.dutchi.com	

Power is our commodity, the world is our market !

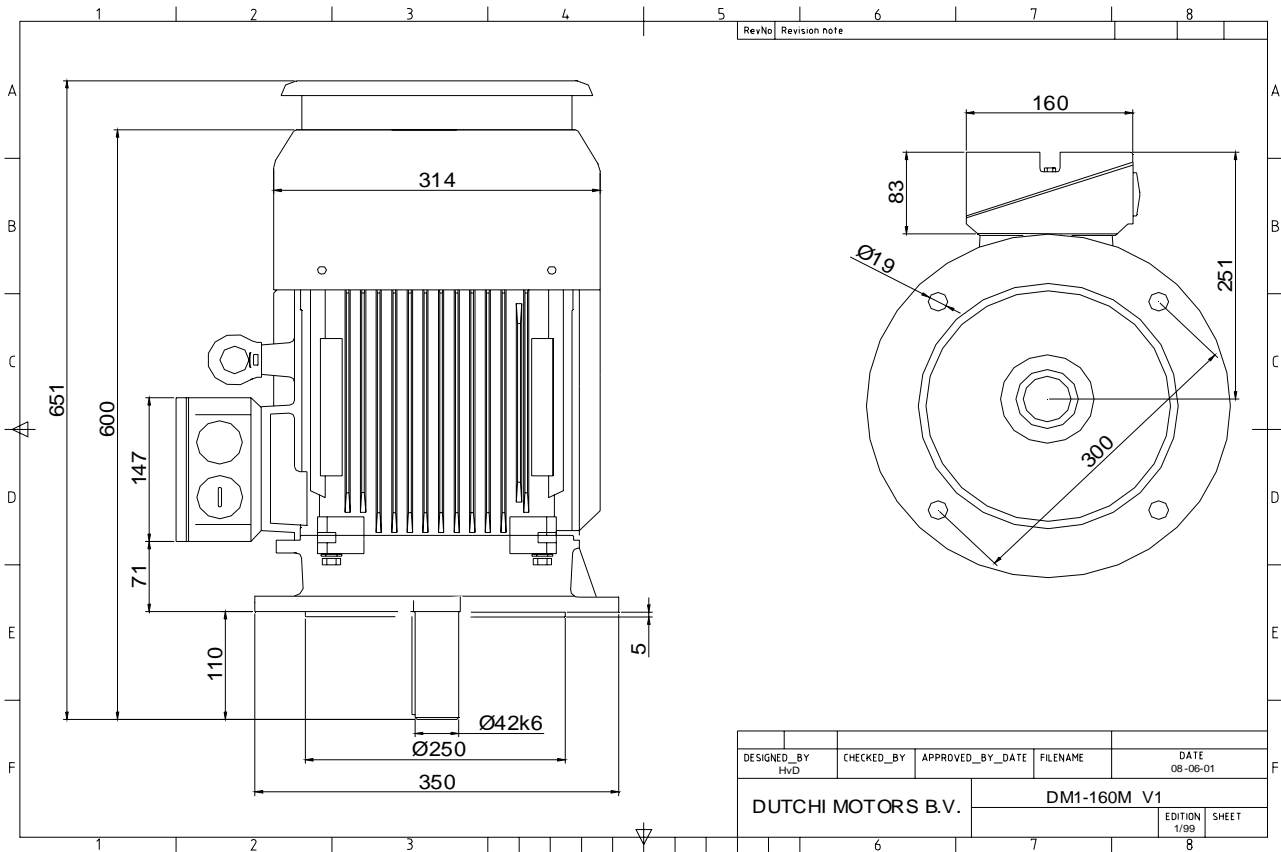

Specification **IEC 60034-1**
 Manufacturer **Dutchi Motors B.V.**
 Motor type **DM1- 160 M4**
 Rated power **11,00 kW S1** duty
 Speed **1460** r.p.m
 Voltage **400 / 690** V
 Frequency **50** Hz
 Connection **Δ / Y**
 Amps full load **21,40 / 12,35** A
 Amps no-load(400V) **8,02** A
 Enclosure **IP 55**
 Insulation Class **F (temp. rise B (80 K))**

Max. coolant temp. **40°C**
 Max. altitude **1.000** mtr, above sea level
 Comment **3 x PTC 150°C**
 Cable entries **2 x M40x1,5 + 1 x M20x1,5 (ptc)**

Feature **Cast-iron motor**
 Weight **113** kg
 Catalog no. **11034A11D**
 Warranty **12~18 months**

Efficiency class **EFF 2**
 Load data 100% 75% 50% 25%
 Efficiency **88,5 89,2 88,3 83,0** %
 Power factor **0,84 0,81 0,71 0,52**

Sound pressure level (1m) **67,2** dB(A)
 Resistance R20 (open) **0,915** Ω
 Resistance R20 **Δ 0,610** Ω

Full load torque **71,95** Nm
 DOL Starting torque vs FL torque **2,04**
 DOL Pull up torque vs FL torque **1,45**
 DOL Pull out torque vs FL torque **2,68**
 Star-Delta Starting torque vs FL torque **0,64**
 Star-Delta Pull up torque vs FL torque **0,45**
 Star-Delta Pull out torque vs FL torque **0,84**
 DOL Starting current vs FL current **6,20**
 Star Delta Starting current vs FL current **1,94**
 Rotor Inertia **0,0724** kgm²

Bearing DE **6309 - ZZ C3**
 Bearing NDE **6309 - ZZ C3**

WI	Change	date	sign.
Dutchi Motors B.V. P.O. Box 5390 NL-6802 EJ ARNHEM Tel : +31-(0)26 - 3541 600 Fax : +31-(0)26 - 3541 650		Discription Drawing made by : 27-04-04	date sign. HvD
dutchi.motors@dutchi.nl www.dutchi.com			