

Power is our commodity, the world is our market !

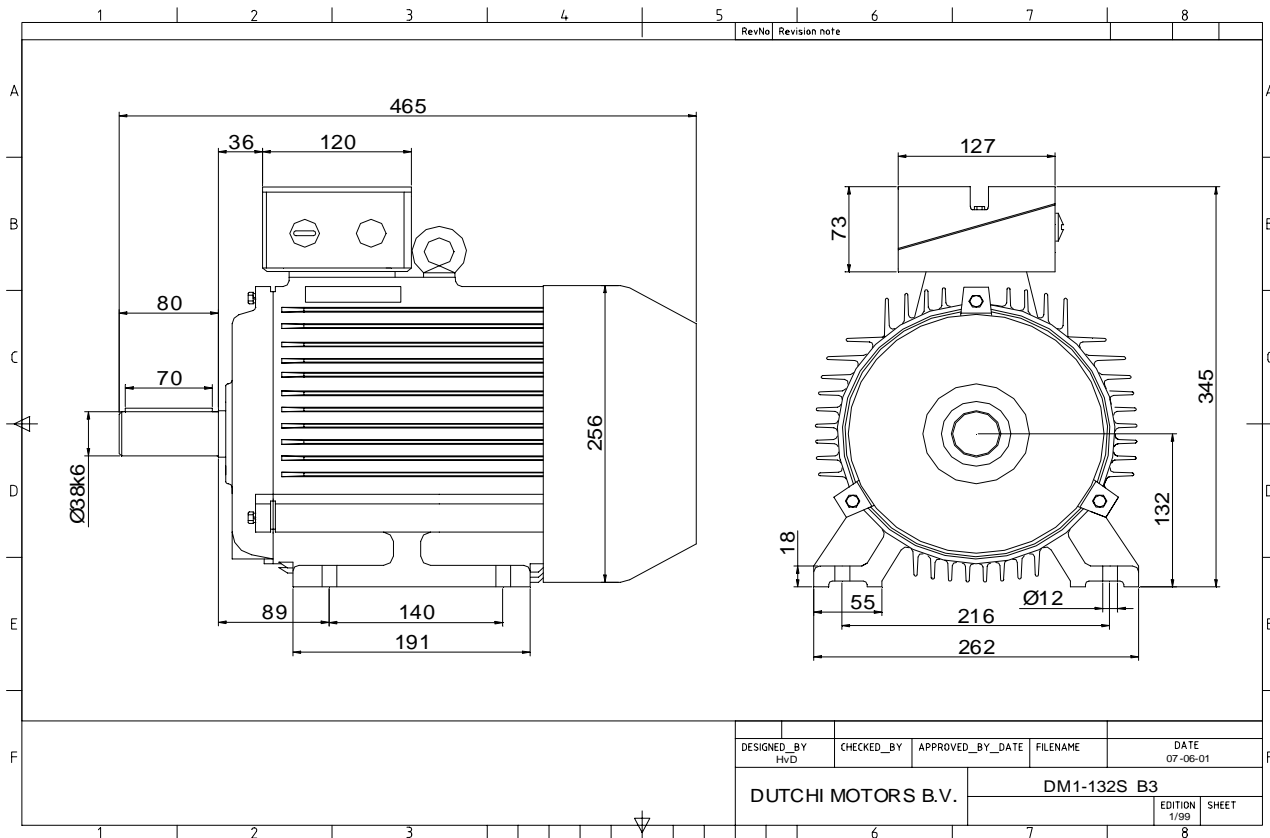

Specification **IEC 60034-1**
 Manufacturer **Dutchi Motors B.V.**
 Motor type **DM1- 132 S4**
 Rated power **5,50** kW **S1** duty
 Speed **1453** r.p.m
 Voltage **400** / **690** V
 Frequency **50** Hz
 Connection **Δ** / **Y**
 Amps full load **10,79** / **6,23** A
 Amps no-load(400V) **4,13** A
 Enclosure **IP 55**
 Insulation Class **F (temp. rise B (80 K))**

Max. coolant temp. **40°C**
 Max. altitude **1.000** mtr, above sea level
 Comment **3 x PTC 150°C**
 Cable entries **2 x M32x1,5 + 1 x M20x1,5 (ptc)**

Feature **Cast-iron motor**
 Weight **61,0** kg
 Catalog no. **11134550D**
 Warranty **12~18 months**

Efficiency class **EFF 2**
 Load data 100% 75% 50% 25%
 Efficiency **85,8 87,2 86,9 81,9** %
 Power factor **0,86 0,82 0,72 0,51**

Sound pressure level (1m) **60,6** dB(A)
 Resistance R20 (open) **2,86** Ω
 Resistance R20 **Δ 1,91** Ω

Full load torque **36,15** Nm
 DOL Starting torque vs FL torque **1,91**
 DOL Pull up torque vs FL torque **1,43**
 DOL Pull out torque vs FL torque **2,89**
 Star-Delta Starting torque vs FL torque **0,60**
 Star-Delta Pull up torque vs FL torque **0,45**
 Star-Delta Pull out torque vs FL torque **0,90**
 DOL Starting current vs FL current **6,23**
 Star Delta Starting current vs FL current **1,95**
 Rotor Inertia **0,0205** kgm²

Bearing DE **6308 - ZZ C3**
 Bearing NDE **6308 - ZZ C3**

WI	Change	date	sign.
Dutchi Motors B.V. P.O. Box 5390 NL-6802 EJ ARNHEM Tel : +31-(0)26 - 3541 600 Fax : +31-(0)26 - 3541 650		Description	date
		Drawing made by :	19-04-04
		dutchi.motors@dutchi.nl www.dutchi.com	

Power is our commodity, the world is our market !

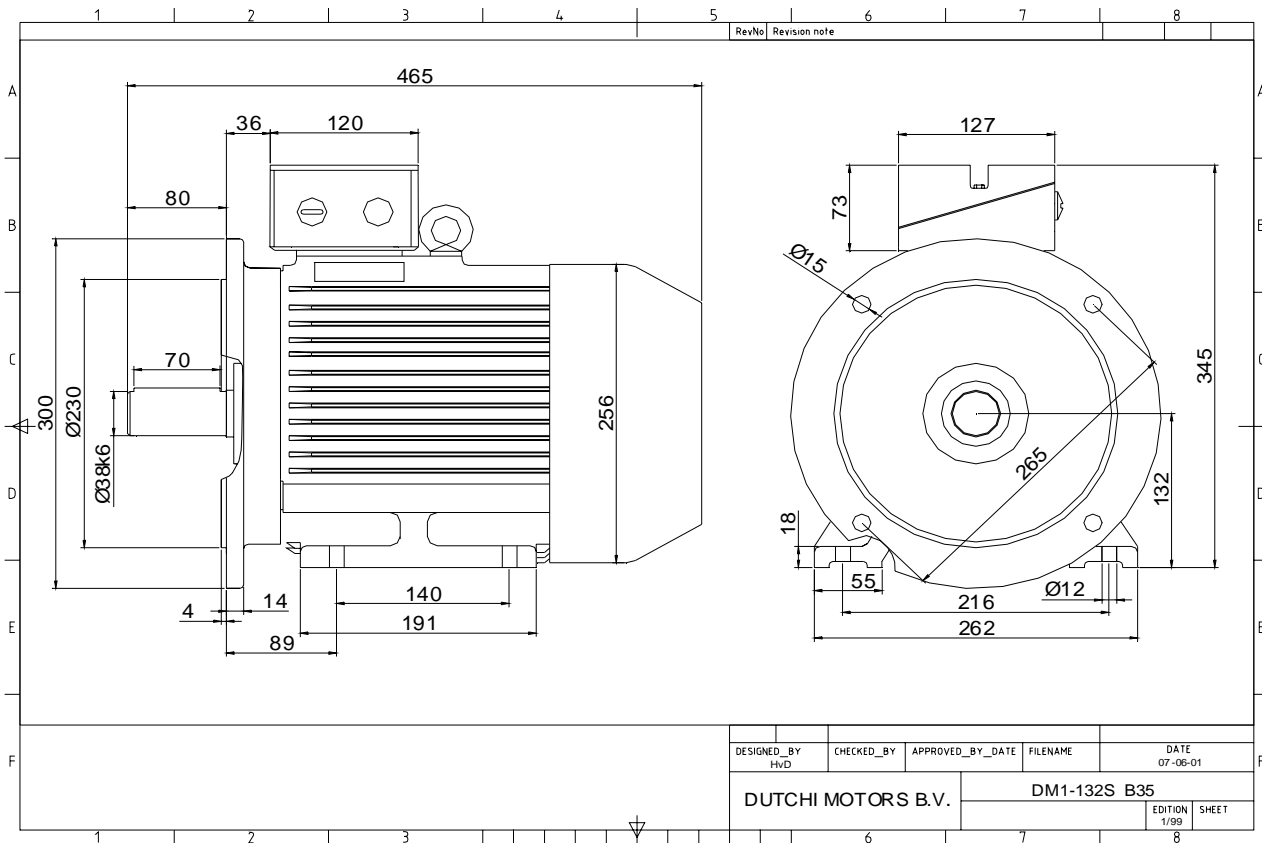

Specification **IEC 60034-1**
 Manufacturer **Dutchi Motors B.V.**
 Motor type **DM1- 132 S4**
 Rated power **5,50** kW **S1** duty
 Speed **1453** r.p.m
 Voltage **400** / **690** V
 Frequency **50** Hz
 Connection **Δ** / **Y**
 Amps full load **10,79** / **6,23** A
 Amps no-load(400V) **4,13** A
 Enclosure **IP 55**
 Insulation Class **F (temp. rise B (80 K))**

Max. coolant temp. **40°C**
 Max. altitude **1.000** mtr, above sea level
 Comment **3 x PTC 150°C**
 Cable entries **2 x M32x1,5 + 1 x M20x1,5 (ptc)**

Feature **Cast-iron motor**
 Weight **61,0** kg
 Catalog no. **11534550D**
 Warranty **12~18 months**

Efficiency class **EFF 2**
 Load data 100% 75% 50% 25%
 Efficiency **85,8 87,2 86,9 81,9** %
 Power factor **0,86 0,82 0,72 0,51**

Sound pressure level (1m) **60,6** dB(A)
 Resistance R20 (open) **2,86** Ω
 Resistance R20 **Δ 1,91** Ω

Full load torque **36,15** Nm
 DOL Starting torque vs FL torque **1,91**
 DOL Pull up torque vs FL torque **1,43**
 DOL Pull out torque vs FL torque **2,89**
 Star-Delta Starting torque vs FL torque **0,60**
 Star-Delta Pull up torque vs FL torque **0,45**
 Star-Delta Pull out torque vs FL torque **0,90**
 DOL Starting current vs FL current **6,23**
 Star Delta Starting current vs FL current **1,95**
 Rotor Inertia **0,0205** kgm²

Bearing DE **6308 - ZZ C3**
 Bearing NDE **6308 - ZZ C3**

WI	Change	date	sign.
Dutchi Motors B.V. P.O. Box 5390 NL-6802 EJ ARNHEM Tel : +31-(0)26 - 3541 600 Fax : +31-(0)26 - 3541 650		Discription Drawing made by :	date sign. HvD
dutchi.motors@dutchi.nl www.dutchi.com		19-04-04	

Power is our commodity, the world is our market !

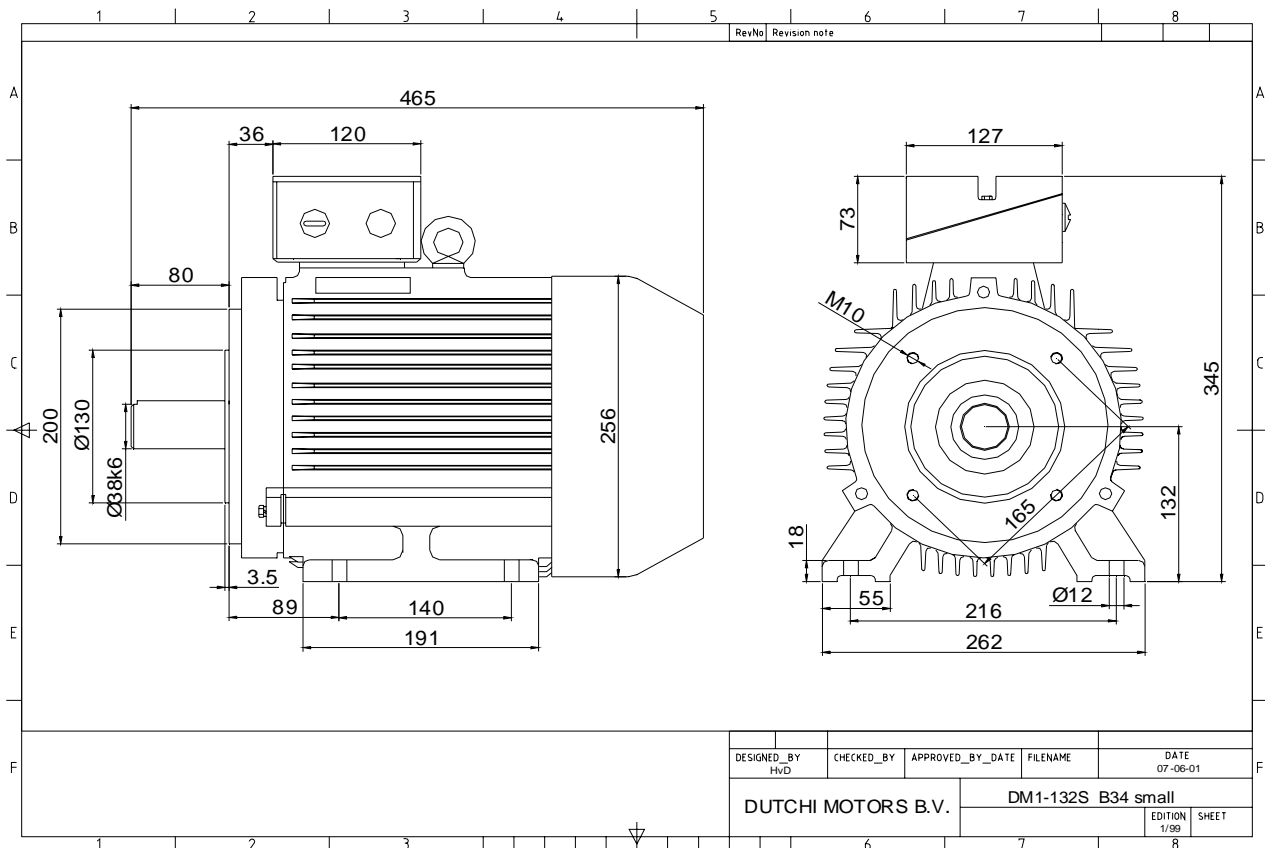

Specification **IEC 60034-1**
 Manufacturer **Dutchi Motors B.V.**
 Motor type **DM1- 132 S4**
 Rated power **5,50** kW **S1** duty
 Speed **1453** r.p.m
 Voltage **400** / **690** V
 Frequency **50** Hz
 Connection **Δ** / **Y**
 Amps full load **10,79** / **6,23** A
 Amps no-load(400V) **4,13** A
 Enclosure **IP 55**
 Insulation Class **F (temp. rise B (80 K))**

Max. coolant temp. **40°C**
 Max. altitude **1.000** mtr, above sea level
 Comment **3 x PTC 150°C**
 Cable entries **2 x M32x1,5 + 1 x M20x1,5 (ptc)**

Feature **Cast-iron motor**
 Weight **61,0** kg
 Catalog no. **11634550D**
 Warranty **12~18 months**

Efficiency class **EFF 2**
 Load data 100% 75% 50% 25%
 Efficiency **85,8 87,2 86,9 81,9** %
 Power factor **0,86 0,82 0,72 0,51**

Sound pressure level (1m) **60,6** dB(A)
 Resistance R20 (open) **2,86** Ω
 Resistance R20 **Δ 1,91** Ω

Full load torque **36,15** Nm
 DOL Starting torque vs FL torque **1,91**
 DOL Pull up torque vs FL torque **1,43**
 DOL Pull out torque vs FL torque **2,89**
 Star-Delta Starting torque vs FL torque **0,60**
 Star-Delta Pull up torque vs FL torque **0,45**
 Star-Delta Pull out torque vs FL torque **0,90**
 DOL Starting current vs FL current **6,23**
 Star Delta Starting current vs FL current **1,95**
 Rotor Inertia **0,0205** kgm²

Bearing DE **6308 - ZZ C3**
 Bearing NDE **6308 - ZZ C3**

WI	Change	date	sign.
Dutchi Motors B.V.		Description	date
P.O. Box 5390		Drawing made by :	19-04-04
NL-6802 EJ ARNHEM			
Tel : +31-(0)26 - 3541 600		dutchi.motors@dutchi.nl	
Fax : +31-(0)26 - 3541 650		www.dutchi.com	

Power is our commodity, the world is our market !

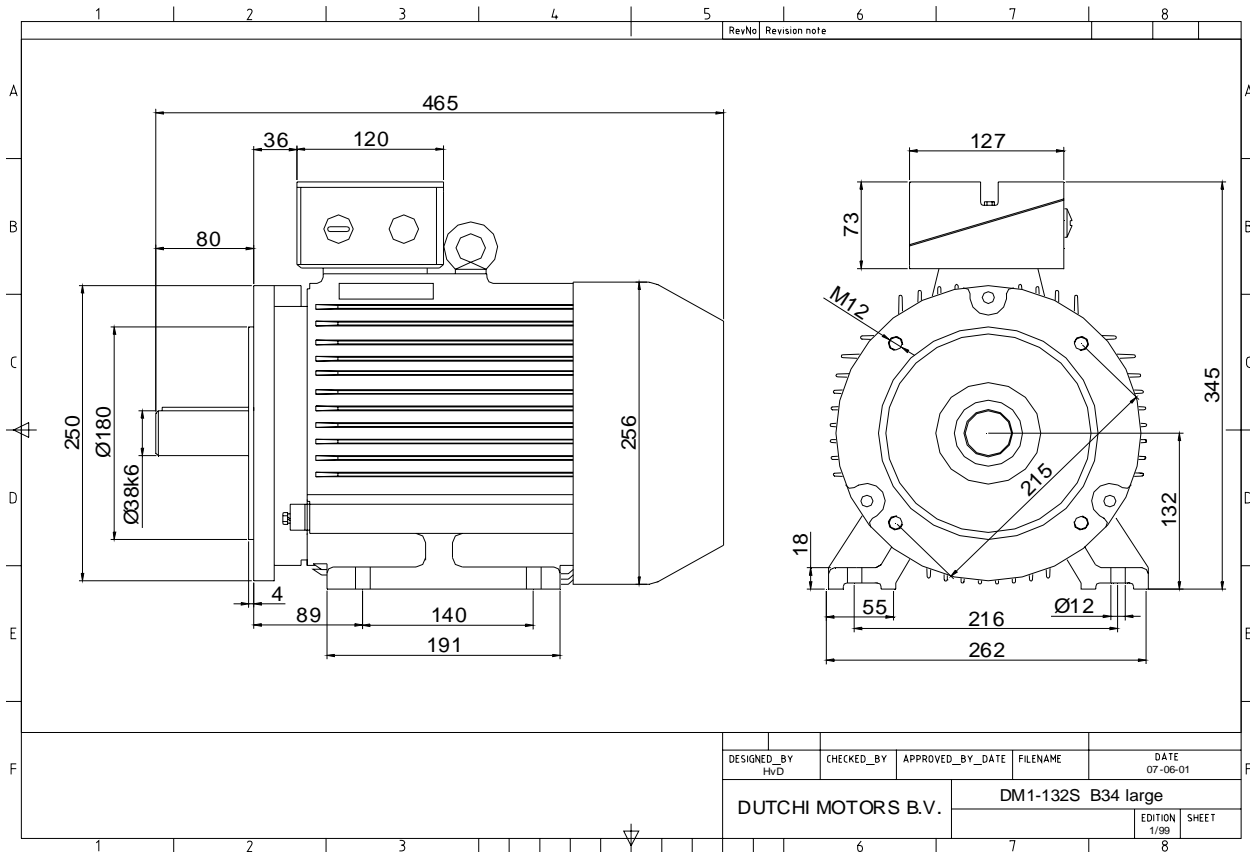

Specification **IEC 60034-1**
 Manufacturer **Dutchi Motors B.V.**
 Motor type **DM1- 132 S4**
 Rated power **5,50** kW **S1** duty
 Speed **1453** r.p.m
 Voltage **400** / **690** V
 Frequency **50** Hz
 Connection **Δ** / **Y**
 Amps full load **10,79** / **6,23** A
 Amps no-load(400V) **4,13** A
 Enclosure **IP 55**
 Insulation Class **F (temp. rise B (80 K))**

Max. coolant temp. **40°C**
 Max. altitude **1.000** mtr, above sea level
 Comment **3 x PTC 150°C**
 Cable entries **2 x M32x1,5 + 1 x M20x1,5 (ptc)**

Feature **Cast-iron motor**
 Weight **61,0** kg
 Catalog no. **11734550D**
 Warranty **12~18 months**

Efficiency class **EFF 2**
 Load data 100% 75% 50% 25%
 Efficiency **85,8 87,2 86,9 81,9** %
 Power factor **0,86 0,82 0,72 0,51**

Sound pressure level (1m) **60,6** dB(A)
 Resistance R20 (open) **2,86** Ω
 Resistance R20 **Δ 1,91** Ω

Full load torque **36,15** Nm
 DOL Starting torque vs FL torque **1,91**
 DOL Pull up torque vs FL torque **1,43**
 DOL Pull out torque vs FL torque **2,89**
 Star-Delta Starting torque vs FL torque **0,60**
 Star-Delta Pull up torque vs FL torque **0,45**
 Star-Delta Pull out torque vs FL torque **0,90**
 DOL Starting current vs FL current **6,23**
 Star Delta Starting current vs FL current **1,95**
 Rotor Inertia **0,0205** kgm2

Bearing DE **6308 - ZZ C3**
 Bearing NDE **6308 - ZZ C3**

WI	Change	date	sign.
Dutchi Motors B.V. P.O. Box 5390 NL-6802 EJ ARNHEM Tel : +31-(0)26 - 3541 600 Fax : +31-(0)26 - 3541 650		Description	date
		Drawing made by :	19-04-04
		dutchi.motors@dutchi.nl www.dutchi.com	

Power is our commodity, the world is our market !

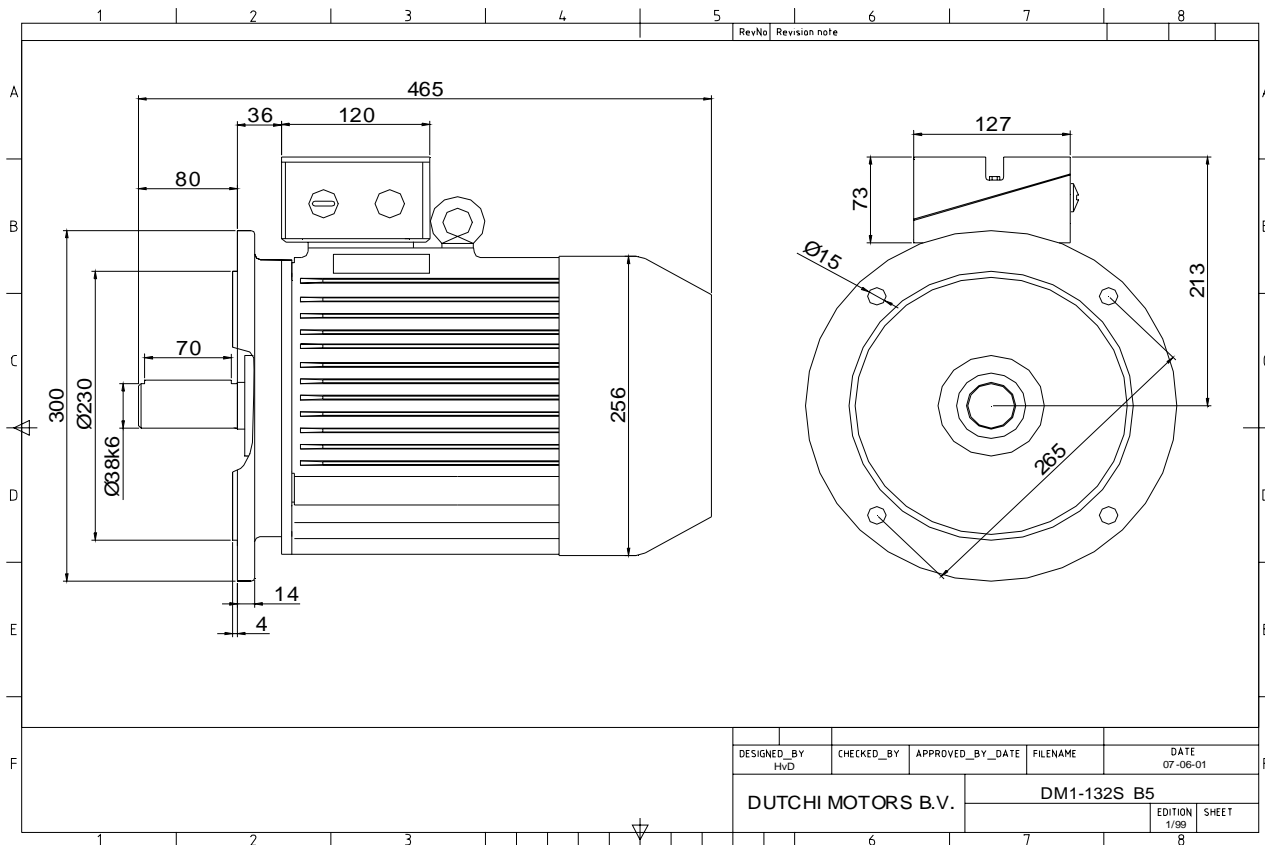

Specification **IEC 60034-1**
 Manufacturer **Dutchi Motors B.V.**
 Motor type **DM1- 132 S4**
 Rated power **5,50** kW **S1** duty
 Speed **1453** r.p.m
 Voltage **400** / **690** V
 Frequency **50** Hz
 Connection **Δ** / **Y**
 Amps full load **10,79** / **6,23** A
 Amps no-load(400V) **4,13** A
 Enclosure **IP 55**
 Insulation Class **F (temp. rise B (80 K))**

Max. coolant temp. **40°C**
 Max. altitude **1.000** mtr, above sea level
 Comment **3 x PTC 150°C**
 Cable entries **2 x M32x1,5 + 1 x M20x1,5 (ptc)**

Feature **Cast-iron motor**
 Weight **61,0** kg
 Catalog no. **11234550D**
 Warranty **12~18 months**

Efficiency class **EFF 2**
 Load data 100% 75% 50% 25%
 Efficiency **85,8 87,2 86,9 81,9** %
 Power factor **0,86 0,82 0,72 0,51**

Sound pressure level (1m) **60,6** dB(A)
 Resistance R20 (open) **2,86** Ω
 Resistance R20 **Δ 1,91** Ω

Full load torque **36,15** Nm
 DOL Starting torque vs FL torque **1,91**
 DOL Pull up torque vs FL torque **1,43**
 DOL Pull out torque vs FL torque **2,89**
 Star-Delta Starting torque vs FL torque **0,60**
 Star-Delta Pull up torque vs FL torque **0,45**
 Star-Delta Pull out torque vs FL torque **0,90**
 DOL Starting current vs FL current **6,23**
 Star Delta Starting current vs FL current **1,95**
 Rotor Inertia **0,0205** kgm2

Bearing DE **6308 - ZZ C3**
 Bearing NDE **6308 - ZZ C3**

WI	Change	date	sign.
Dutchi Motors B.V. P.O. Box 5390 NL-6802 EJ ARNHEM Tel : +31-(0)26 - 3541 600 Fax : +31-(0)26 - 3541 650		Description	date
		Drawing made by :	19-04-04
		dutchi.motors@dutchi.nl www.dutchi.com	

Power is our commodity, the world is our market !

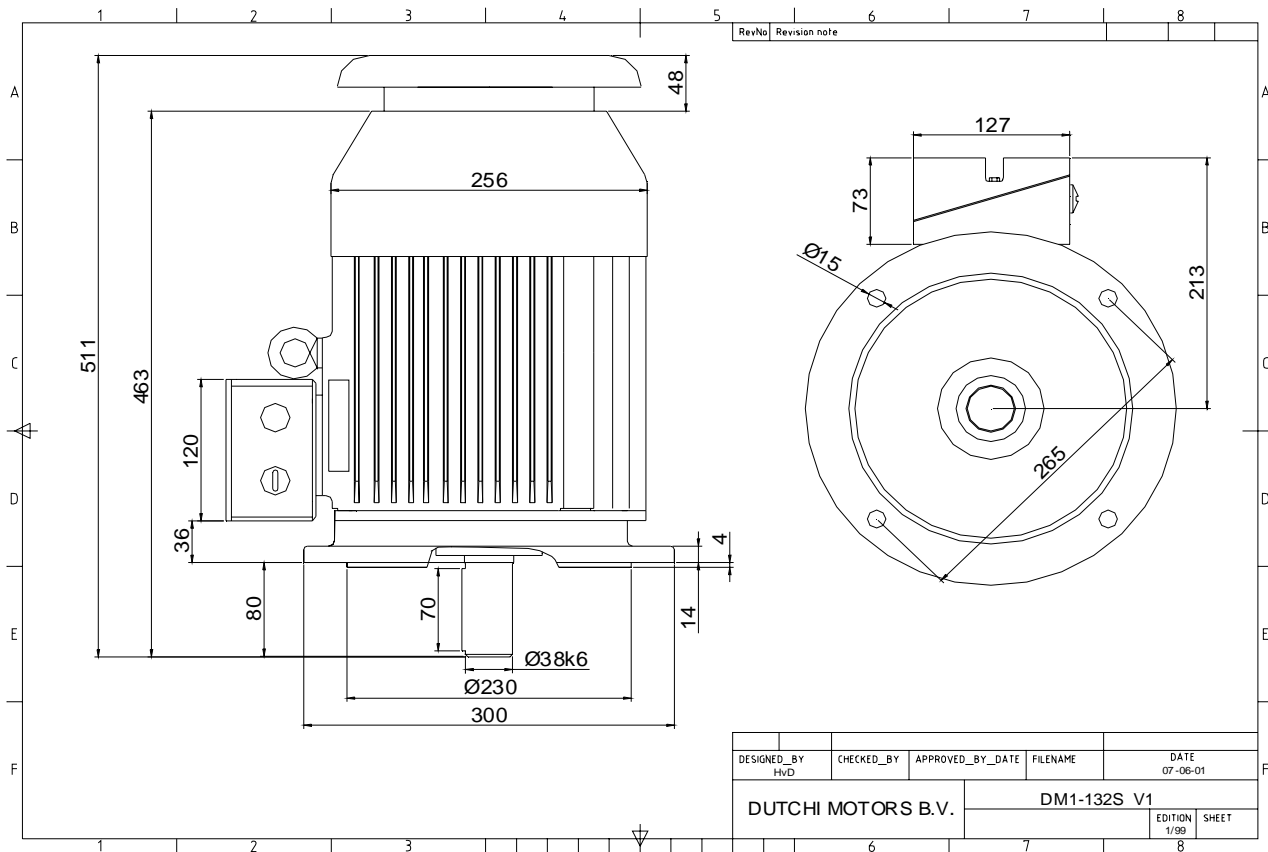

Specification **IEC 60034-1**
 Manufacturer **Dutchi Motors B.V.**
 Motor type **DM1- 132 S4**
 Rated power **5,50** kW **S1** duty
 Speed **1453** r.p.m
 Voltage **400** / **690** V
 Frequency **50** Hz
 Connection **Δ** / **Y**
 Amps full load **10,79** / **6,23** A
 Amps no-load(400V) **4,13** A
 Enclosure **IP 55**
 Insulation Class **F (temp. rise B (80 K))**

Max. coolant temp. **40°C**
 Max. altitude **1.000** mtr, above sea level
 Comment **3 x PTC 150°C**
 Cable entries **2 x M32x1,5 + 1 x M20x1,5 (ptc)**

Feature **Cast-iron motor**
 Weight **61,0** kg
 Catalog no. **11034550D**
 Warranty **12~18 months**

Efficiency class **EFF 2**
 Load data 100% 75% 50% 25%
 Efficiency **85,8 87,2 86,9 81,9** %
 Power factor **0,86 0,82 0,72 0,51**

Sound pressure level (1m) **60,6** dB(A)
 Resistance R20 (open) **2,86** Ω
 Resistance R20 **Δ 1,91** Ω

Full load torque **36,15** Nm
 DOL Starting torque vs FL torque **1,91**
 DOL Pull up torque vs FL torque **1,43**
 DOL Pull out torque vs FL torque **2,89**
 Star-Delta Starting torque vs FL torque **0,60**
 Star-Delta Pull up torque vs FL torque **0,45**
 Star-Delta Pull out torque vs FL torque **0,90**
 DOL Starting current vs FL current **6,23**
 Star Delta Starting current vs FL current **1,95**
 Rotor Inertia **0,0205** kgm2

Bearing DE **6308 - ZZ C3**
 Bearing NDE **6308 - ZZ C3**

WI	Change	date	sign.
Dutchi Motors B.V. P.O. Box 5390 NL-6802 EJ ARNHEM Tel : +31-(0)26 - 3541 600 Fax : +31-(0)26 - 3541 650		Discription Drawing made by :	date sign. HvD
dutchi.motors@dutchi.nl www.dutchi.com		19-04-04	

Power is our commodity, the world is our market !

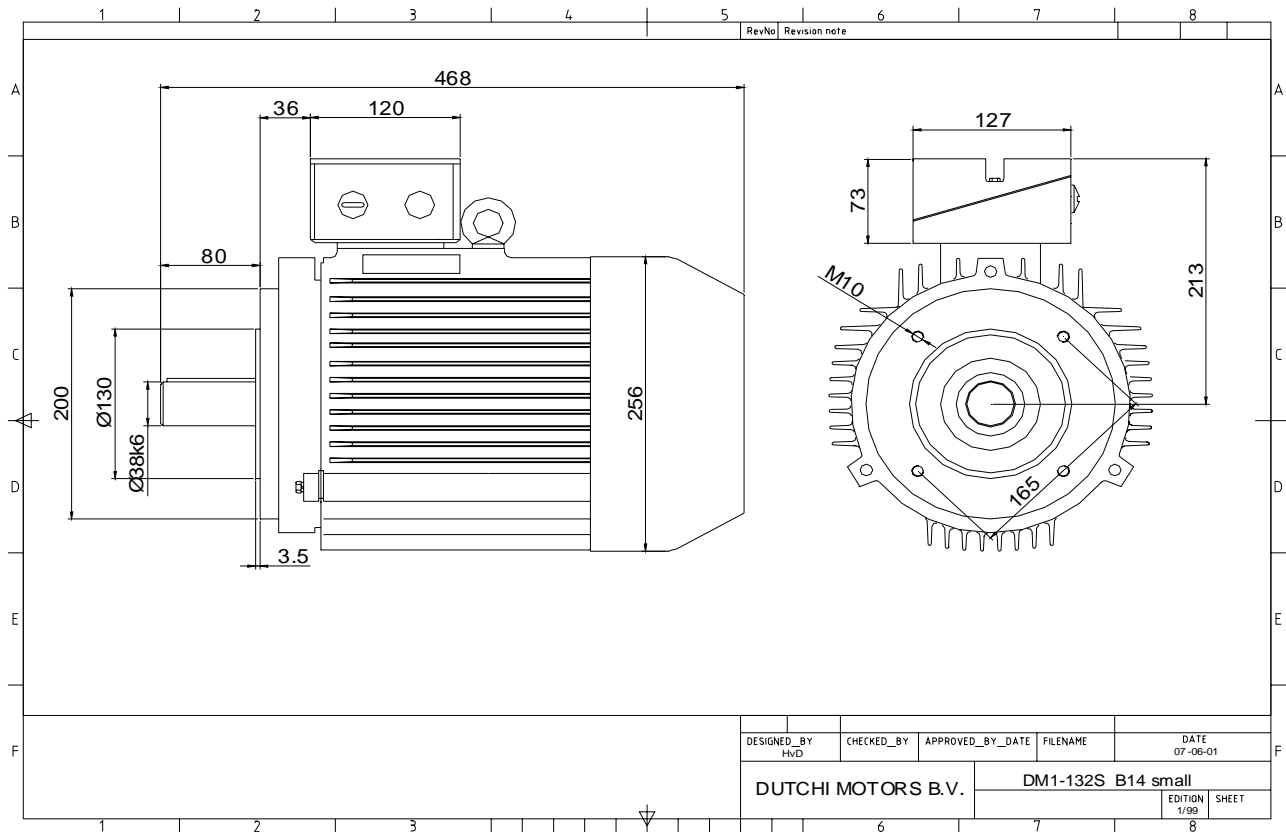

Specification **IEC 60034-1**
 Manufacturer **Dutchi Motors B.V.**
 Motor type **DM1- 132 S4**
 Rated power **5,50** kW **S1** duty
 Speed **1453** r.p.m
 Voltage **400** / **690** V
 Frequency **50** Hz
 Connection **Δ** / **Y**
 Amps full load **10,79** / **6,23** A
 Amps no-load(400V) **4,13** A
 Enclosure **IP 55**
 Insulation Class **F (temp. rise B (80 K))**

Max. coolant temp. **40°C**
 Max. altitude **1.000** mtr, above sea level
 Comment **3 x PTC 150°C**
 Cable entries **2 x M32x1,5 + 1 x M20x1,5 (ptc)**

Feature **Cast-iron motor**
 Weight **61,0** kg
 Catalog no. **11334550D**
 Warranty **12~18 months**

Efficiency class **EFF 2**
 Load data 100% 75% 50% 25%
 Efficiency **85,8 87,2 86,9 81,9** %
 Power factor **0,86 0,82 0,72 0,51**

Sound pressure level (1m) **60,6** dB(A)
 Resistance R20 (open) **2,86** Ω
 Resistance R20 **Δ 1,91** Ω

Full load torque **36,15** Nm
 DOL Starting torque vs FL torque **1,91**
 DOL Pull up torque vs FL torque **1,43**
 DOL Pull out torque vs FL torque **2,89**
 Star-Delta Starting torque vs FL torque **0,60**
 Star-Delta Pull up torque vs FL torque **0,45**
 Star-Delta Pull out torque vs FL torque **0,90**
 DOL Starting current vs FL current **6,23**
 Star Delta Starting current vs FL current **1,95**
 Rotor Inertia **0,0205** kgm2

Bearing DE **6308 - ZZ C3**
 Bearing NDE **6308 - ZZ C3**

WI	Change	date	sign.
Dutchi Motors B.V.		Description	date
P.O. Box 5390		Drawing made by :	19-04-04
NL-6802 EJ ARNHEM			
Tel : +31-(0)26 - 3541 600		dutchi.motors@dutchi.nl	
Fax : +31-(0)26 - 3541 650		www.dutchi.com	

Power is our commodity, the world is our market !

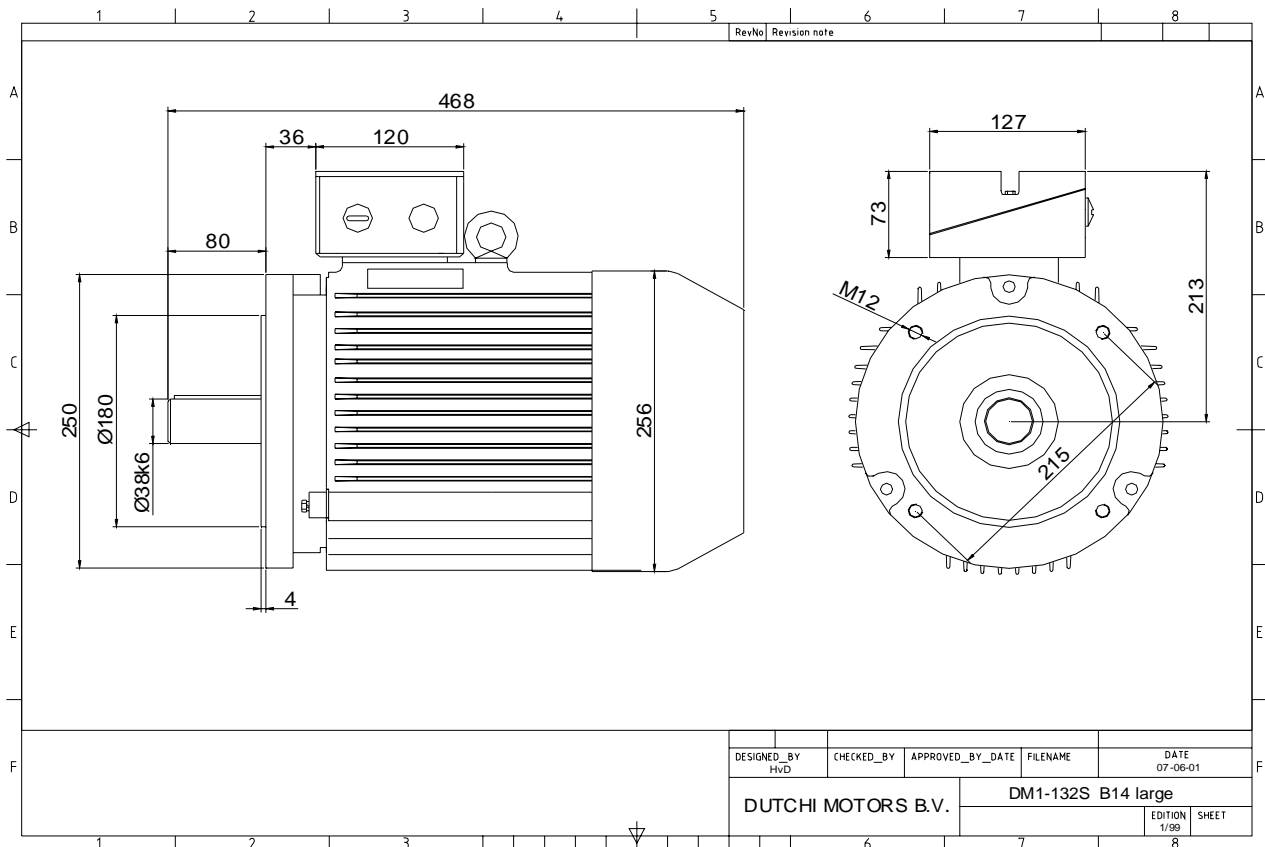

Specification **IEC 60034-1**
 Manufacturer **Dutchi Motors B.V.**
 Motor type **DM1- 132 S4**
 Rated power **5,50** kW **S1** duty
 Speed **1453** r.p.m
 Voltage **400 / 690** V
 Frequency **50** Hz
 Connection **Δ / Y**
 Amps full load **10,79 / 6,23** A
 Amps no-load(400V) **4,13** A
 Enclosure **IP 55**
 Insulation Class **F (temp. rise B (80 K))**

Max. coolant temp. **40°C**
 Max. altitude **1.000** mtr, above sea level
 Comment **3 x PTC 150°C**
 Cable entries **2 x M32x1,5 + 1 x M20x1,5 (ptc)**

Feature **Cast-iron motor**
 Weight **61,0** kg
 Catalog no. **11434550D**
 Warranty **12~18 months**

Efficiency class **EFF 2**
 Load data 100% 75% 50% 25%
 Efficiency **85,8 87,2 86,9 81,9** %
 Power factor **0,86 0,82 0,72 0,51**

Sound pressure level (1m) **60,6** dB(A)
 Resistance R20 (open) **2,86** Ω
 Resistance R20 **Δ 1,91** Ω

Full load torque **36,15** Nm
 DOL Starting torque vs FL torque **1,91**
 DOL Pull up torque vs FL torque **1,43**
 DOL Pull out torque vs FL torque **2,89**
 Star-Delta Starting torque vs FL torque **0,60**
 Star-Delta Pull up torque vs FL torque **0,45**
 Star-Delta Pull out torque vs FL torque **0,90**
 DOL Starting current vs FL current **6,23**
 Star Delta Starting current vs FL current **1,95**
 Rotor Inertia **0,0205** kgm²

Bearing DE **6308 - ZZ C3**
 Bearing NDE **6308 - ZZ C3**

WI	Change	date	sign.
Dutchi Motors B.V.		Description	date
P.O. Box 5390		Drawing made by :	19-04-04
NL-6802 EJ ARNHEM			
Tel : +31-(0)26 - 3541 600		dutchi.motors@dutchi.nl	
Fax : +31-(0)26 - 3541 650		www.dutchi.com	