

Power is our commodity, the world is our market !

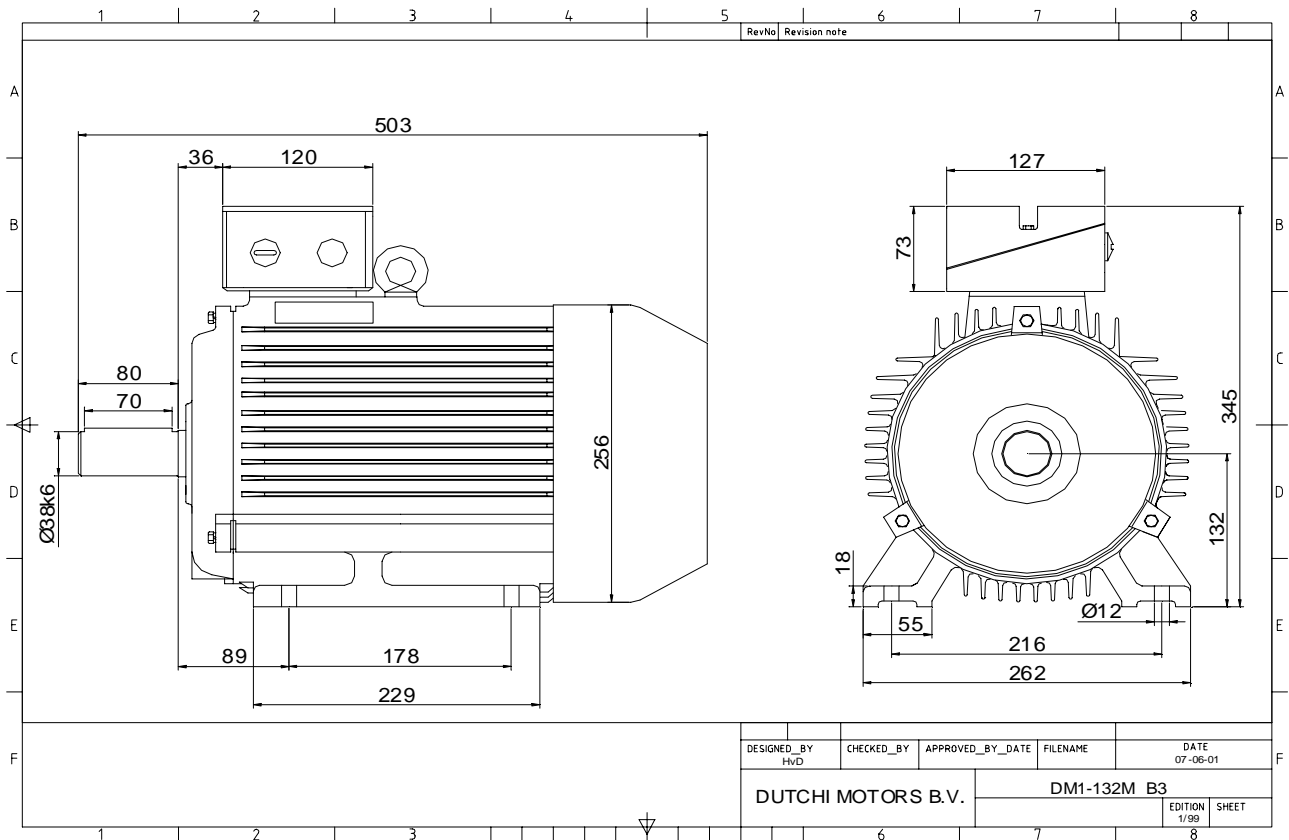

Specification **IEC 60034-1**
 Manufacturer **Dutchi Motors B.V.**
 Motor type **DM1- 132 M4**
 Rated power **7,50** kW **S1** duty
 Speed **1452** r.p.m
 Voltage **400** / **690** V
 Frequency **50** Hz
 Connection **Δ** / **Y**
 Amps full load **14,46** / **8,35** A
 Amps no-load(400V) **5,57** A
 Enclosure **IP 55**
 Insulation Class **F (temp. rise B (80 K))**

Max. coolant temp. **40°C**
 Max. altitude **1.000** mtr, above sea level
 Comment **3 x PTC 150°C**
 Cable entries **2 x M32x1,5 + 1 x M20x1,5 (ptc)**

Feature **Cast-iron motor**
 Weight **73,0** kg
 Catalog no. **11134750D**
 Warranty **12~18 months**

Efficiency class **EFF 2**
 Load data 100% 75% 50% 25%
 Efficiency **87,0 88,1 87,5 82,3** %
 Power factor **0,86 0,82 0,72 0,51**

Sound pressure level (1m) **56,5** dB(A)
 Resistance R20 (open) **1,83** Ω
 Resistance R20 **Δ 1,22** Ω

Full load torque **49,33** Nm
 DOL Starting torque vs FL torque **2,43**
 DOL Pull up torque vs FL torque **1,74**
 DOL Pull out torque vs FL torque **3,24**
 Star-Delta Starting torque vs FL torque **0,76**
 Star-Delta Pull up torque vs FL torque **0,54**
 Star-Delta Pull out torque vs FL torque **1,01**
 DOL Starting current vs FL current **7,11**
 Star Delta Starting current vs FL current **2,22**
 Rotor Inertia **0,0296** kgm²

Bearing DE **6308 - ZZ C3**
 Bearing NDE **6308 - ZZ C3**

WI	Change	date	sign.
Dutchi Motors B.V.		Description	date
P.O. Box 5390		Drawing made by :	19-04-04
NL-6802 EJ ARNHEM			
Tel : +31-(0)26 - 3541 600		dutchi.motors@dutchi.nl	
Fax : +31-(0)26 - 3541 650		www.dutchi.com	

Power is our commodity, the world is our market !

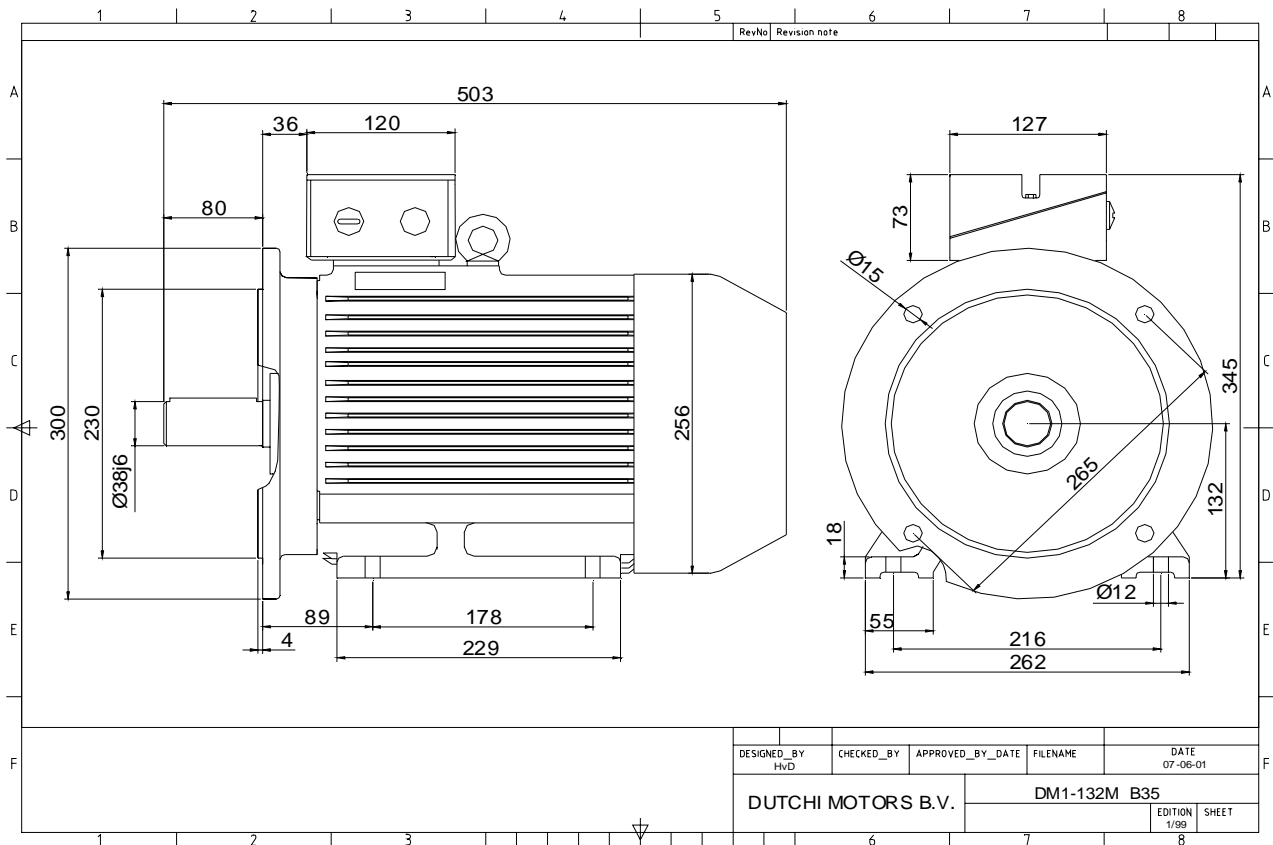

Specification **IEC 60034-1**
 Manufacturer **Dutchi Motors B.V.**
 Motor type **DM1- 132 M4**
 Rated power **7,50** kW **S1** duty
 Speed **1452** r.p.m
 Voltage **400 / 690** V
 Frequency **50** Hz
 Connection **Δ / Y**
 Amps full load **14,46 / 8,35** A
 Amps no-load(400V) **5,57** A
 Enclosure **IP 55**
 Insulation Class **F (temp. rise B (80 K))**

Max. coolant temp. **40°C**
 Max. altitude **1.000** mtr, above sea level
 Comment **3 x PTC 150°C**
 Cable entries **2 x M32x1,5 + 1 x M20x1,5 (ptc)**

Feature **Cast-iron motor**
 Weight **73,0** kg
 Catalog no. **11534750D**
 Warranty **12~18 months**

Efficiency class **EFF 2**
 Load data 100% 75% 50% 25%
 Efficiency **87,0 88,1 87,5 82,3** %
 Power factor **0,86 0,82 0,72 0,51**

Sound pressure level (1m) **56,5** dB(A)
 Resistance R20 (open) **1,83** Ω
 Resistance R20 **Δ 1,22** Ω

Full load torque **49,33** Nm
 DOL Starting torque vs FL torque **2,43**
 DOL Pull up torque vs FL torque **1,74**
 DOL Pull out torque vs FL torque **3,24**
 Star-Delta Starting torque vs FL torque **0,76**
 Star-Delta Pull up torque vs FL torque **0,54**
 Star-Delta Pull out torque vs FL torque **1,01**
 DOL Starting current vs FL current **7,11**
 Star Delta Starting current vs FL current **2,22**
 Rotor Inertia **0,0296** kgm²

Bearing DE **6308 - ZZ C3**
 Bearing NDE **6308 - ZZ C3**

WI	Change	date	sign.
Dutchi Motors B.V. P.O. Box 5390 NL-6802 EJ ARNHEM Tel : +31-(0)26 - 3541 600 Fax : +31-(0)26 - 3541 650		Discription Drawing made by : 19-04-04	date sign. HVD
dutchi.motors@dutchi.nl www.dutchi.com			

Power is our commodity, the world is our market !

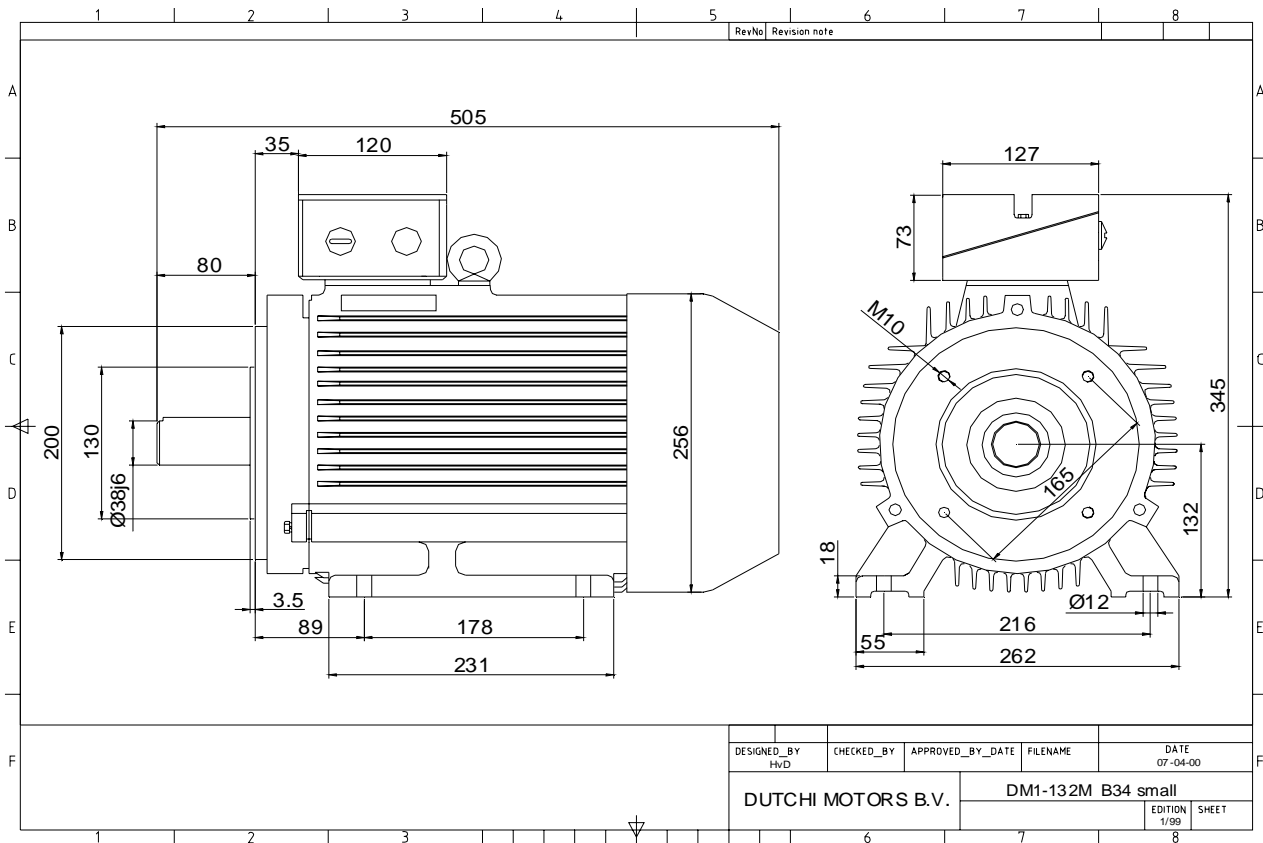

Specification **IEC 60034-1**
 Manufacturer **Dutchi Motors B.V.**
 Motor type **DM1- 132 M4**
 Rated power **7,50** kW **S1** duty
 Speed **1452** r.p.m
 Voltage **400** / **690** V
 Frequency **50** Hz
 Connection **Δ** / **Y**
 Amps full load **14,46** / **8,35** A
 Amps no-load(400V) **5,57** A
 Enclosure **IP 55**
 Insulation Class **F (temp. rise B (80 K))**

Max. coolant temp. **40°C**
 Max. altitude **1.000** mtr, above sea level
 Comment **3 x PTC 150°C**
 Cable entries **2 x M32x1,5 + 1 x M20x1,5 (ptc)**

Feature **Cast-iron motor**
 Weight **73,0** kg
 Catalog no. **11634750D**
 Warranty **12~18 months**

Efficiency class **EFF 2**
 Load data 100% 75% 50% 25%
 Efficiency **87,0 88,1 87,5 82,3** %
 Power factor **0,86 0,82 0,72 0,51**

Sound pressure level (1m) **56,5** dB(A)
 Resistance R20 (open) **1,83** Ω
 Resistance R20 **Δ 1,22** Ω

Full load torque **49,33** Nm
 DOL Starting torque vs FL torque **2,43**
 DOL Pull up torque vs FL torque **1,74**
 DOL Pull out torque vs FL torque **3,24**
 Star-Delta Starting torque vs FL torque **0,76**
 Star-Delta Pull up torque vs FL torque **0,54**
 Star-Delta Pull out torque vs FL torque **1,01**
 DOL Starting current vs FL current **7,11**
 Star Delta Starting current vs FL current **2,22**
 Rotor Inertia **0,0296** kgm2

Bearing DE **6308 - ZZ C3**
 Bearing NDE **6308 - ZZ C3**

WI	Change	date	sign.
Dutchi Motors B.V.		Description	date
P.O. Box 5390		Drawing made by :	19-04-04
NL-6802 EJ ARNHEM			
Tel : +31-(0)26 - 3541 600		dutchi.motors@dutchi.nl	
Fax : +31-(0)26 - 3541 650		www.dutchi.com	

Power is our commodity, the world is our market !

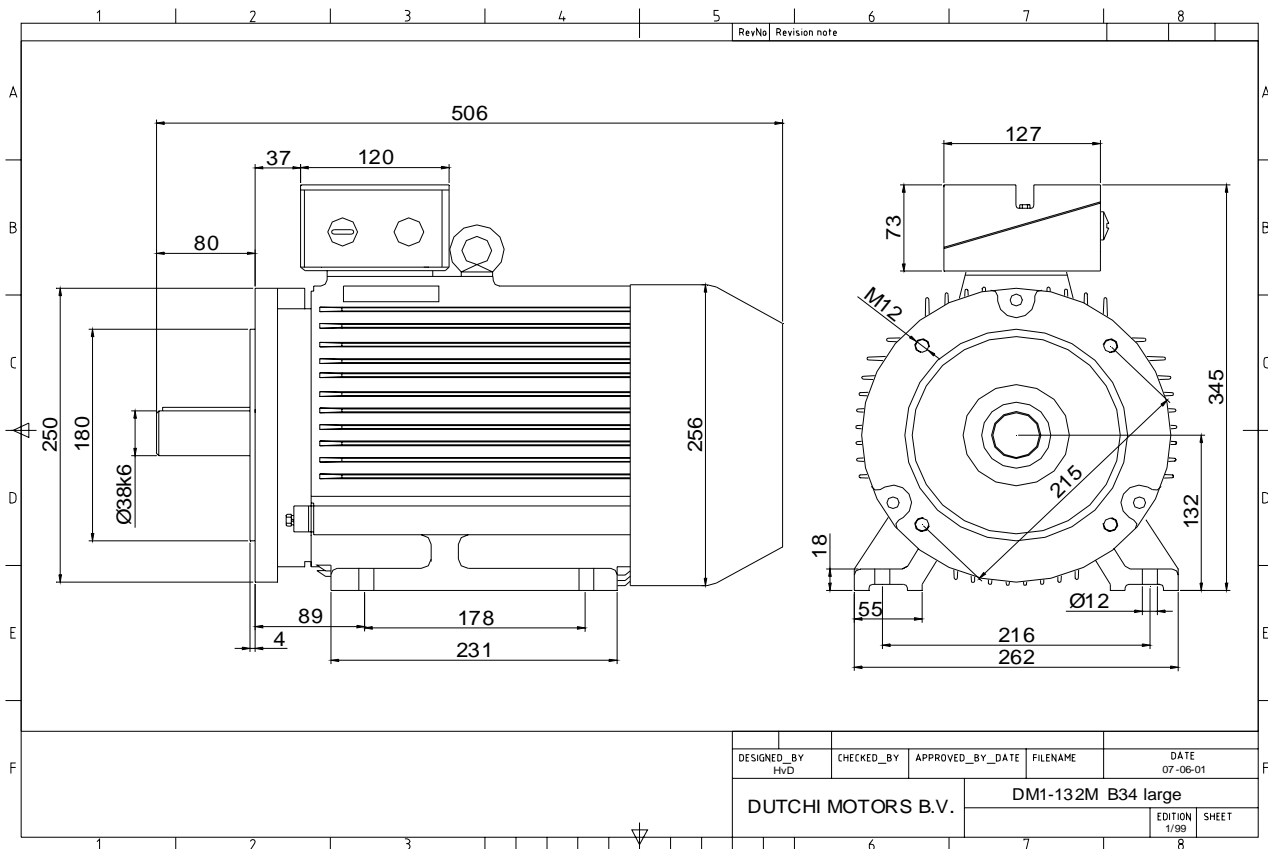

Specification **IEC 60034-1**
 Manufacturer **Dutchi Motors B.V.**
 Motor type **DM1- 132 M4**
 Rated power **7,50** kW **S1** duty
 Speed **1452** r.p.m
 Voltage **400 / 690** V
 Frequency **50** Hz
 Connection **Δ / Y**
 Amps full load **14,46 / 8,35** A
 Amps no-load(400V) **5,57** A
 Enclosure **IP 55**
 Insulation Class **F (temp. rise B (80 K))**

Max. coolant temp. **40°C**
 Max. altitude **1.000** mtr, above sea level
 Comment **3 x PTC 150°C**
 Cable entries **2 x M32x1,5 + 1 x M20x1,5 (ptc)**

Feature **Cast-iron motor**
 Weight **73,0** kg
 Catalog no. **12134750D**
 Warranty **12~18 months**

Efficiency class **EFF 2**
 Load data 100% 75% 50% 25%
 Efficiency **87,0 88,1 87,5 82,3** %
 Power factor **0,86 0,82 0,72 0,51**

Sound pressure level (1m) **56,5** dB(A)
 Resistance R20 (open) **1,83** Ω
 Resistance R20 **Δ 1,22** Ω

Full load torque **49,33** Nm
 DOL Starting torque vs FL torque **2,43**
 DOL Pull up torque vs FL torque **1,74**
 DOL Pull out torque vs FL torque **3,24**
 Star-Delta Starting torque vs FL torque **0,76**
 Star-Delta Pull up torque vs FL torque **0,54**
 Star-Delta Pull out torque vs FL torque **1,01**
 DOL Starting current vs FL current **7,11**
 Star Delta Starting current vs FL current **2,22**
 Rotor Inertia **0,0296** kgm²

Bearing DE **6308 - ZZ C3**
 Bearing NDE **6308 - ZZ C3**

WI	Change	date	sign.
Dutchi Motors B.V. P.O. Box 5390 NL-6802 EJ ARNHEM Tel : +31-(0)26 - 3541 600 Fax : +31-(0)26 - 3541 650		Discription Drawing made by : 19-04-04	date sign. HVD
dutchi.motors@dutchi.nl www.dutchi.com			

Power is our commodity, the world is our market !

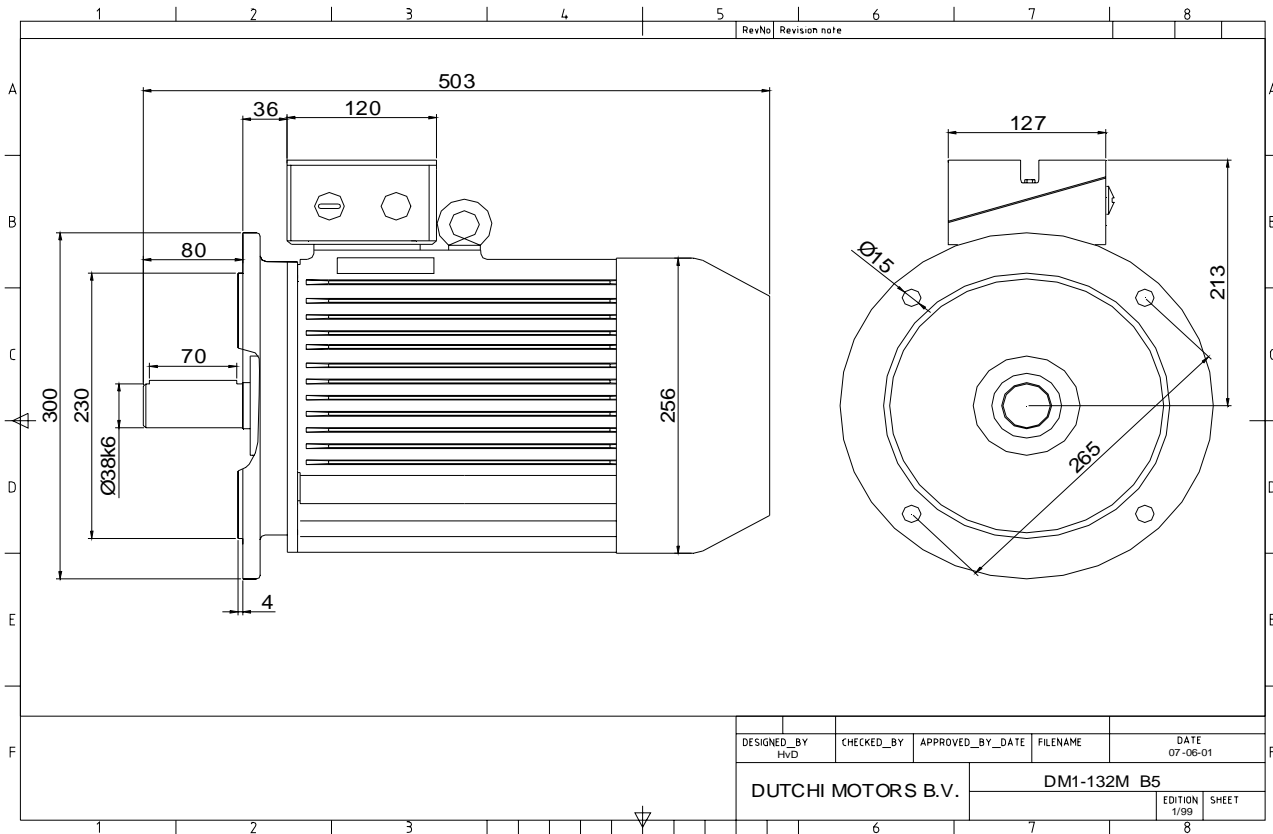

DESIGNED_BY HvD	CHECKED_BY	APPROVED_BY_DATE	FILENAME	DATE 07-06-01
DUTCHI MOTORS B.V.			DM1-132M B5	
			EDITION 1/99	SHEET

Specification	IEC 60034-1
Manufacturer	Dutchi Motors B.V.
Motor type	DM1- 132 M4
Rated power	7,50 kW S1 duty
Speed	1452 r.p.m
Voltage	400 / 690 V
Frequency	50 Hz
Connection	Δ / Y
Amps full load	14,46 / 8,35 A
Amps no-load(400V)	5,57 A
Enclosure	IP 55
Insulation Class	F (temp. rise B (80 K))
Max. coolant temp.	40°C
Max. altitude	1.000 mtr, above sea level
Comment	3 x PTC 150°C
Cable entries	2 x M32x1,5 + 1 x M20x1,5 (ptc)
Feature	Cast-iron motor
Weight	73,0 kg
Catalog no.	11234750D
Warranty	12~18 months

Efficiency class	EFF 2			
Load data	100%	75%	50%	25%
Efficiency	87,0	88,1	87,5	82,3 %
Power factor	0,86	0,82	0,72	0,51
Sound pressure level (1m)				56,5 dB(A)
Resistance R20 (open)				1,83 Ω
Resistance R20	Δ			1,22 Ω
Full load torque				49,33 Nm
DOL Starting torque vs FL torque				2,43
DOL Pull up torque vs FL torque				1,74
DOL Pull out torque vs FL torque				3,24
Star-Delta Starting torque vs FL torque				0,76
Star-Delta Pull up torque vs FL torque				0,54
Star-Delta Pull out torque vs FL torque				1,01
DOL Starting current vs FL current				7,11
Star Delta Starting current vs FL current				2,22
Rotor Inertia				0,0296 kgm ²
Bearing DE				6308 - ZZ C3
Bearing NDE				6308 - ZZ C3

WI	Change	date	sign.
Dutchi Motors B.V. P.O. Box 5390 NL-6802 EJ ARNHEM Tel : +31-(0)26 - 3541 600 Fax : +31-(0)26 - 3541 650		Discription Drawing made by :	date 19-04-04 sign. HvD
		dutchi.motors@dutchi.nl www.dutchi.com	

Power is our commodity, the world is our market !

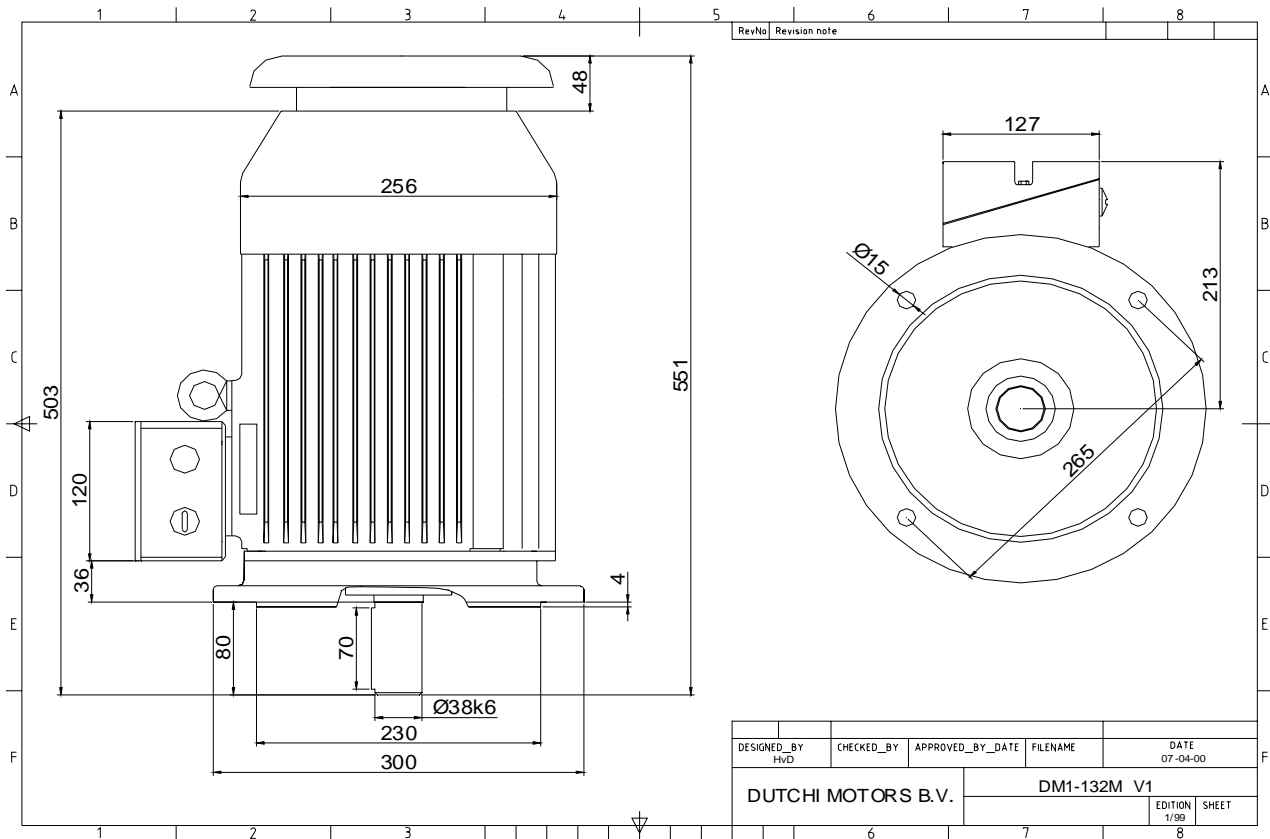

Specification **IEC 60034-1**
 Manufacturer **Dutchi Motors B.V.**
 Motor type **DM1- 132 M4**
 Rated power **7,50** kW **S1** duty
 Speed **1452** r.p.m
 Voltage **400** / **690** V
 Frequency **50** Hz
 Connection **Δ** / **Y**
 Amps full load **14,46** / **8,35** A
 Amps no-load(400V) **5,57** A
 Enclosure **IP 55**
 Insulation Class **F (temp. rise B (80 K))**

Max. coolant temp. **40°C**
 Max. altitude **1.000** mtr, above sea level
 Comment **3 x PTC 150°C**
 Cable entries **2 x M32x1,5 + 1 x M20x1,5 (ptc)**

Feature **Cast-iron motor**
 Weight **73,0** kg
 Catalog no. **11034750D**
 Warranty **12~18 months**

Efficiency class **EFF 2**
 Load data 100% 75% 50% 25%
 Efficiency **87,0 88,1 87,5 82,3** %
 Power factor **0,86 0,82 0,72 0,51**

Sound pressure level (1m) **56,5** dB(A)
 Resistance R20 (open) **1,83** Ω
 Resistance R20 **Δ 1,22** Ω

Full load torque **49,33** Nm
 DOL Starting torque vs FL torque **2,43**
 DOL Pull up torque vs FL torque **1,74**
 DOL Pull out torque vs FL torque **3,24**
 Star-Delta Starting torque vs FL torque **0,76**
 Star-Delta Pull up torque vs FL torque **0,54**
 Star-Delta Pull out torque vs FL torque **1,01**
 DOL Starting current vs FL current **7,11**
 Star Delta Starting current vs FL current **2,22**
 Rotor Inertia **0,0296** kgm²

Bearing DE **6308 - ZZ C3**
 Bearing NDE **6308 - ZZ C3**

WI	Change	date	sign.
Dutchi Motors B.V. P.O. Box 5390 NL-6802 EJ ARNHEM Tel : +31-(0)26 - 3541 600 Fax : +31-(0)26 - 3541 650		Discription Drawing made by :	date 19-04-04 sign. HvD
dutchi.motors@dutchi.nl www.dutchi.com			

Power is our commodity, the world is our market !

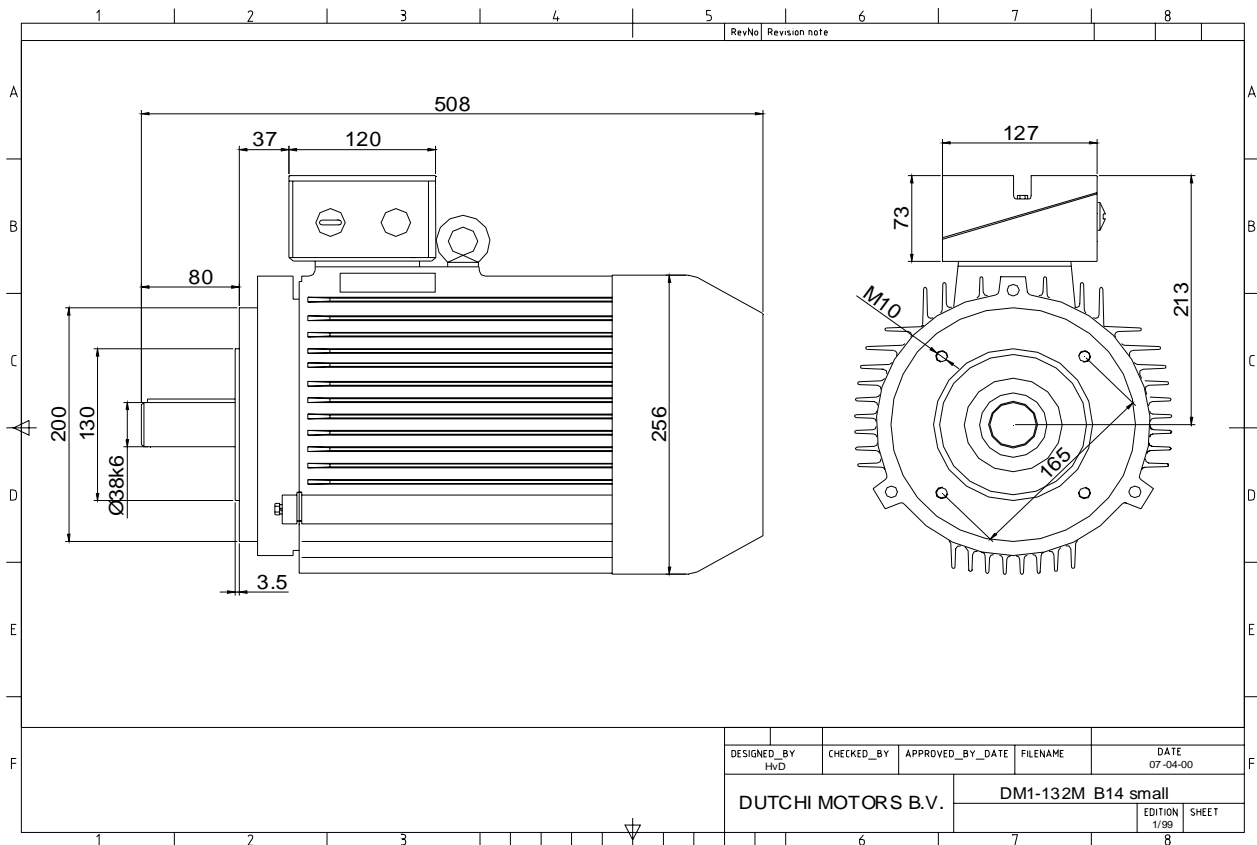

Specification **IEC 60034-1**
 Manufacturer **Dutchi Motors B.V.**
 Motor type **DM1- 132 M4**
 Rated power **7,50** kW **S1** duty
 Speed **1452** r.p.m
 Voltage **400** / **690** V
 Frequency **50** Hz
 Connection **Δ** / **Y**
 Amps full load **14,46** / **8,35** A
 Amps no-load(400V) **5,57** A
 Enclosure **IP 55**
 Insulation Class **F (temp. rise B (80 K))**

Max. coolant temp. **40°C**
 Max. altitude **1.000** mtr, above sea level
 Comment **3 x PTC 150°C**
 Cable entries **2 x M32x1,5 + 1 x M20x1,5 (ptc)**

Feature **Cast-iron motor**
 Weight **73,0** kg
 Catalog no. **11334750D**
 Warranty **12~18 months**

Efficiency class **EFF 2**
 Load data 100% 75% 50% 25%
 Efficiency **87,0 88,1 87,5 82,3** %
 Power factor **0,86 0,82 0,72 0,51**

Sound pressure level (1m) **56,5** dB(A)
 Resistance R20 (open) **1,83** Ω
 Resistance R20 **Δ 1,22** Ω

Full load torque **49,33** Nm
 DOL Starting torque vs FL torque **2,43**
 DOL Pull up torque vs FL torque **1,74**
 DOL Pull out torque vs FL torque **3,24**
 Star-Delta Starting torque vs FL torque **0,76**
 Star-Delta Pull up torque vs FL torque **0,54**
 Star-Delta Pull out torque vs FL torque **1,01**
 DOL Starting current vs FL current **7,11**
 Star Delta Starting current vs FL current **2,22**
 Rotor Inertia **0,0296** kgm²

Bearing DE **6308 - ZZ C3**
 Bearing NDE **6308 - ZZ C3**

WI	Change	date	sign.
Dutchi Motors B.V. P.O. Box 5390 NL-6802 EJ ARNHEM Tel : +31-(0)26 - 3541 600 Fax : +31-(0)26 - 3541 650		Discription Drawing made by : 19-04-04	date sign. HvD
dutchi.motors@dutchi.nl www.dutchi.com			

Power is our commodity, the world is our market !

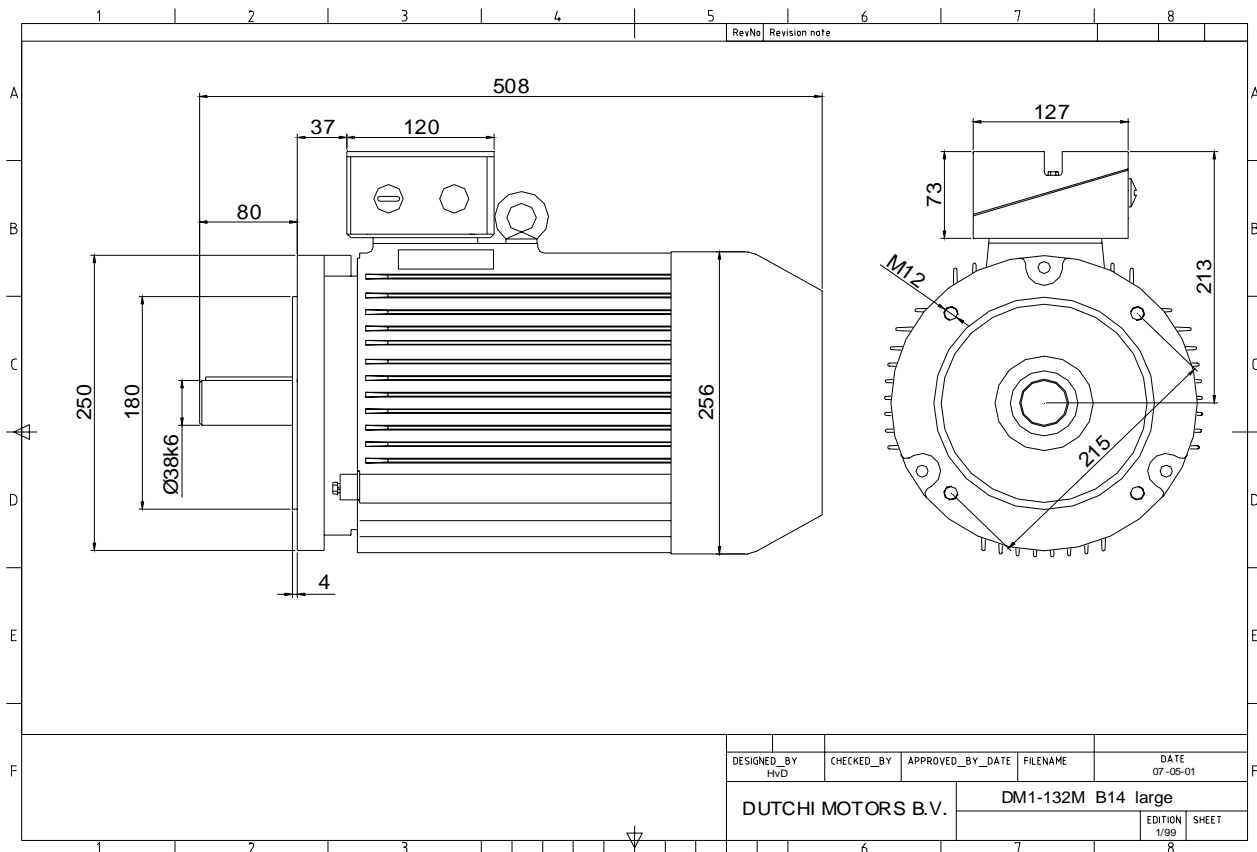

Specification **IEC 60034-1**
 Manufacturer **Dutchi Motors B.V.**
 Motor type **DM1- 132 M4**
 Rated power **7,50** kW **S1** duty
 Speed **1452** r.p.m
 Voltage **400** / **690** V
 Frequency **50** Hz
 Connection **Δ** / **Y**
 Amps full load **14,46** / **8,35** A
 Amps no-load(400V) **5,57** A
 Enclosure **IP 55**
 Insulation Class **F (temp. rise B (80 K))**

Max. coolant temp. **40°C**
 Max. altitude **1.000** mtr, above sea level
 Comment **3 x PTC 150°C**
 Cable entries **2 x M32x1,5 + 1 x M20x1,5 (ptc)**

Feature **Cast-iron motor**
 Weight **73,0** kg
 Catalog no. **11434750D**
 Warranty **12~18 months**

Efficiency class **EFF 2**
 Load data 100% 75% 50% 25%
 Efficiency **87,0 88,1 87,5 82,3** %
 Power factor **0,86 0,82 0,72 0,51**

Sound pressure level (1m) **56,5** dB(A)
 Resistance R20 (open) **1,83** Ω
 Resistance R20 **Δ 1,22** Ω

Full load torque **49,33** Nm
 DOL Starting torque vs FL torque **2,43**
 DOL Pull up torque vs FL torque **1,74**
 DOL Pull out torque vs FL torque **3,24**
 Star-Delta Starting torque vs FL torque **0,76**
 Star-Delta Pull up torque vs FL torque **0,54**
 Star-Delta Pull out torque vs FL torque **1,01**
 DOL Starting current vs FL current **7,11**
 Star Delta Starting current vs FL current **2,22**
 Rotor Inertia **0,0296** kgm²

Bearing DE **6308 - ZZ C3**
 Bearing NDE **6308 - ZZ C3**

WI	Change	date	sign.
Dutchi Motors B.V. P.O. Box 5390 NL-6802 EJ ARNHEM Tel : +31-(0)26 - 3541 600 Fax : +31-(0)26 - 3541 650		Description	date
		Drawing made by :	19-04-04
		dutchi.motors@dutchi.nl www.dutchi.com	