

Power is our commodity, the world is our market !

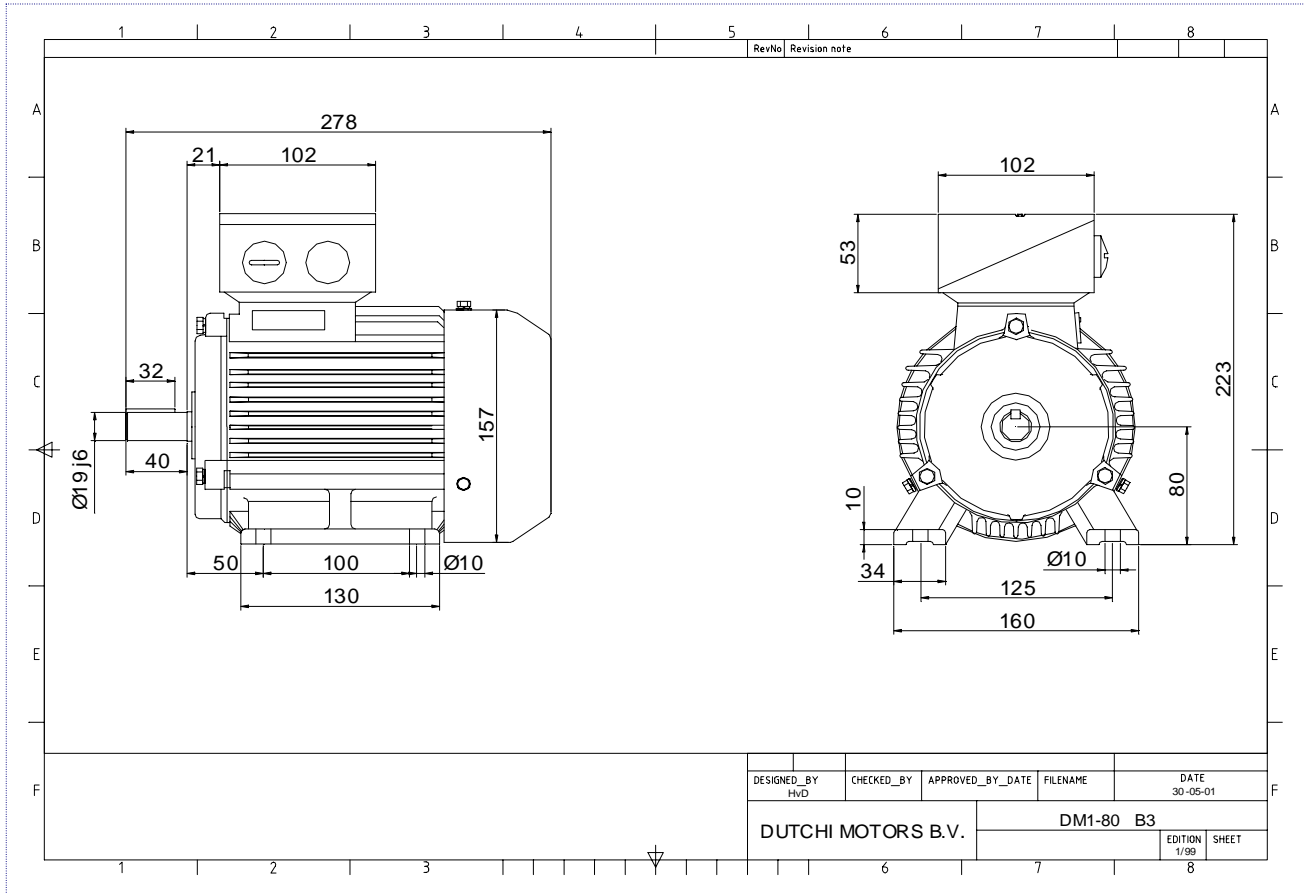

Specification	IEC 60034-1
Manufacturer	Dutchi Motors B.V.
Motor type	DM1- 80 K6
Rated power	0,37 kW S1 duty
Speed	900 r.p.m
Voltage	230 / 400 V
Frequency	50 Hz
Connection	Δ / Y
Amps full load	2,03 / 1,17 A
Amps no-load(400V)	1,00 A
Enclosure	IP 55
Insulation Class	F (temp. rise B (80 K))
Max. coolant temp.	40°C
Max. altitude	1.000 mtr, above sea level
Comment	3 x PTC 150°C
Cable entries	2 x M25x1,5 + 1 x M20x1,5 (ptc)
Feature	Cast-iron motor
Weight	17,0 kg
Catalog no.	11126037D
Warranty	12~18 months

Efficiency class	N/A
Load data	100% 75% 50% 25%
Efficiency	62,9 60,4 55,7 38,2 %
Power factor	0,72 0,61 0,51 0,35
Sound pressure level (1m)	44,0 dB(A)
Resistance R20 (open)	23,85 Ω
Resistance R20	Y 47,69 Ω
Full load torque	3,93 Nm
DOL Starting torque vs FL torque	1,99
DOL Pull up torque vs FL torque	1,47
DOL Pull out torque vs FL torque	2,78
Star-Delta Starting torque vs FL torque	Y - motor
Star-Delta Pull up torque vs FL torque	Y - motor
Star-Delta Pull out torque vs FL torque	Y - motor
DOL Starting current vs FL current	3,50
Star Delta Starting current vs FL current	Y - motor
Rotor Inertia	0,0016 kgm ²
Bearing DE	6204 - ZZ
Bearing NDE	6204 - ZZ

Extras / Options :

WI	Change	date	sign.
Dutchi Motors B.V. P.O. Box 5390 NL-6802 EJ ARNHEM Tel : +31-(0)26 - 3541 600 Fax : +31-(0)26 - 3541 650		Discription Drawing made by :	date 19-04-04 sign. HvD
dutchi.motors@dutchi.nl www.dutchi.com			

Power is our commodity, the world is our market !

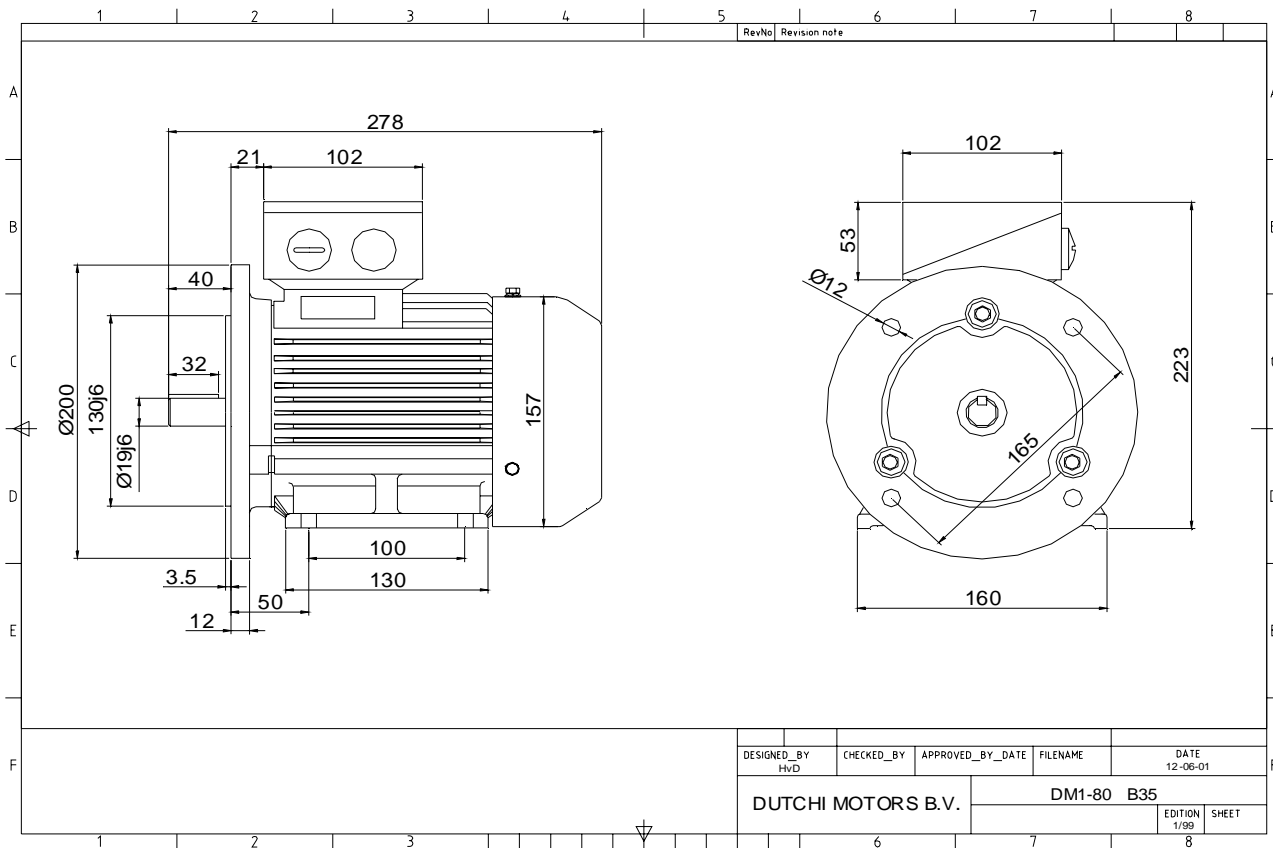

Specification	IEC 60034-1
Manufacturer	Dutchi Motors B.V.
Motor type	DM1- 80 K6
Rated power	0,37 kW S1 duty
Speed	900 r.p.m
Voltage	230 / 400 V
Frequency	50 Hz
Connection	Δ / Y
Amps full load	2,03 / 1,17 A
Amps no-load(400V)	1,00 A
Enclosure	IP 55
Insulation Class	F (temp. rise B (80 K))
Max. coolant temp.	40°C
Max. altitude	1.000 mtr, above sea level
Comment	3 x PTC 150°C
Cable entries	2 x M25x1,5 + 1 x M20x1,5 (ptc)
Feature	Cast-iron motor
Weight	17,0 kg
Catalog no.	11526037D
Warranty	12~18 months

Efficiency class	N/A			
Load data	100%	75%	50%	25%
Efficiency	62,9	60,4	55,7	38,2 %
Power factor	0,72	0,61	0,51	0,35
Sound pressure level (1m)				44,0 dB(A)
Resistance R20 (open)				23,85 Ω
Resistance R20	Y		47,69	Ω
Full load torque				3,93 Nm
DOL Starting torque vs FL torque				1,99
DOL Pull up torque vs FL torque				1,47
DOL Pull out torque vs FL torque				2,78
Star-Delta Starting torque vs FL torque				Y - motor
Star-Delta Pull up torque vs FL torque				Y - motor
Star-Delta Pull out torque vs FL torque				Y - motor
DOL Starting current vs FL current				3,50
Star Delta Starting current vs FL current				Y - motor
Rotor Inertia				0,0016 kgm ²
Bearing DE				6204 - ZZ
Bearing NDE				6204 - ZZ

Extras / Options :

WI	Change	date	sign.
Dutchi Motors B.V. P.O. Box 5390 NL-6802 EJ ARNHEM Tel : +31-(0)26 - 3541 600 Fax : +31-(0)26 - 3541 650		Discription Drawing made by :	date 19-04-04
dutchi.motors@dutchi.nl www.dutchi.com		sign. HvD	

Power is our commodity, the world is our market !

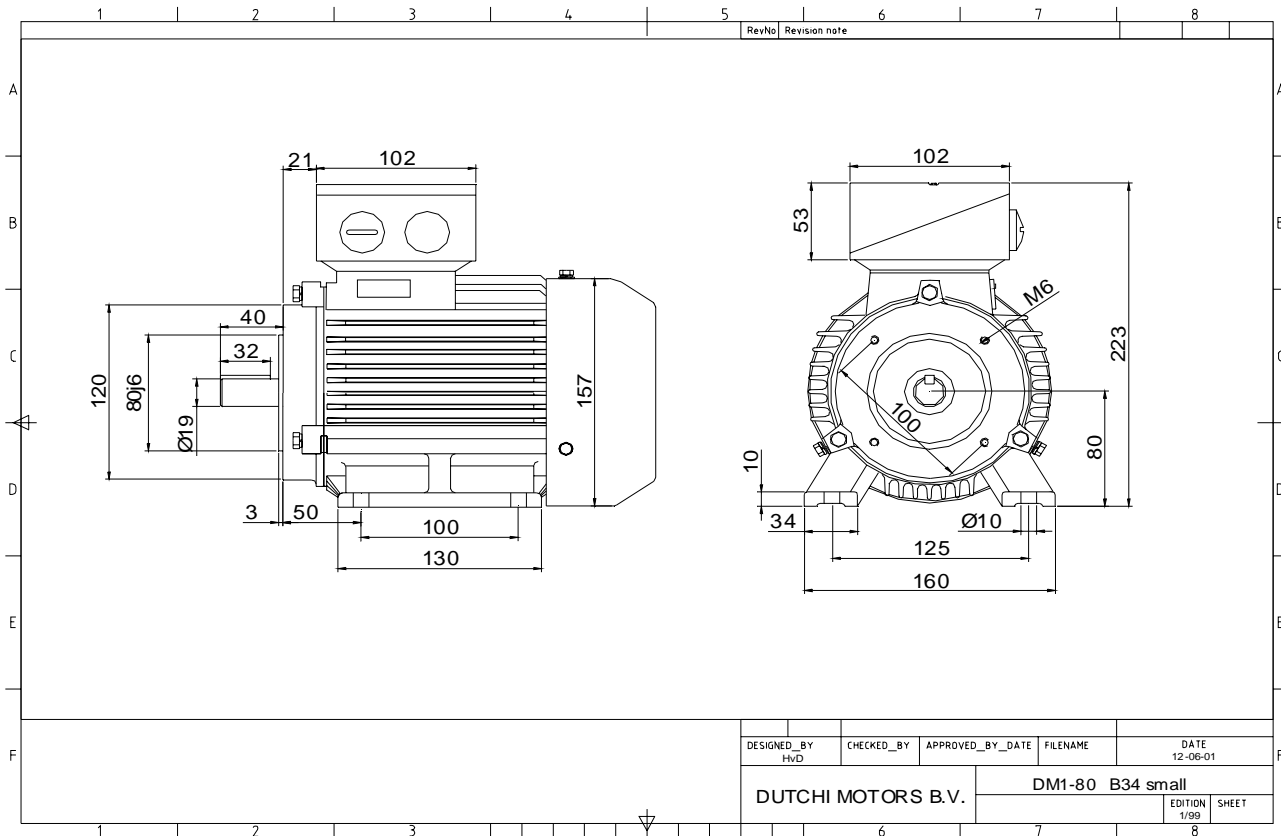

Specification	IEC 60034-1
Manufacturer	Dutchi Motors B.V.
Motor type	DM1- 80 K6
Rated power	0,37 kW S1 duty
Speed	900 r.p.m
Voltage	230 / 400 V
Frequency	50 Hz
Connection	Δ / Y
Amps full load	2,03 / 1,17 A
Amps no-load(400V)	1,00 A
Enclosure	IP 55
Insulation Class	F (temp. rise B (80 K))
Max. coolant temp.	40°C
Max. altitude	1.000 mtr, above sea level
Comment	3 x PTC 150°C
Cable entries	2 x M25x1,5 + 1 x M20x1,5 (ptc)
Feature	Cast-iron motor
Weight	17,0 kg
Catalog no.	11626037D
Warranty	12~18 months

Efficiency class	N/A			
Load data	100%	75%	50%	25%
Efficiency	62,9	60,4	55,7	38,2 %
Power factor	0,72	0,61	0,51	0,35
Sound pressure level (1m)				44,0 dB(A)
Resistance R20 (open)				23,85 Ω
Resistance R20	Y			47,69 Ω
Full load torque				3,93 Nm
DOL Starting torque vs FL torque				1,99
DOL Pull up torque vs FL torque				1,47
DOL Pull out torque vs FL torque				2,78
Star-Delta Starting torque vs FL torque				Y - motor
Star-Delta Pull up torque vs FL torque				Y - motor
Star-Delta Pull out torque vs FL torque				Y - motor
DOL Starting current vs FL current				3,50
Star Delta Starting current vs FL current				Y - motor
Rotor Inertia				0,0016 kgm ²
Bearing DE				6204 - ZZ
Bearing NDE				6204 - ZZ

Extras / Options :

WI	Change	date	sign.
Dutchi Motors B.V. P.O. Box 5390 NL-6802 EJ ARNHEM Tel : +31-(0)26 - 3541 600 Fax : +31-(0)26 - 3541 650		Description	date
		Drawing made by :	19-04-04
		dutchi.motors@dutchi.nl www.dutchi.com	

Power is our commodity, the world is our market !

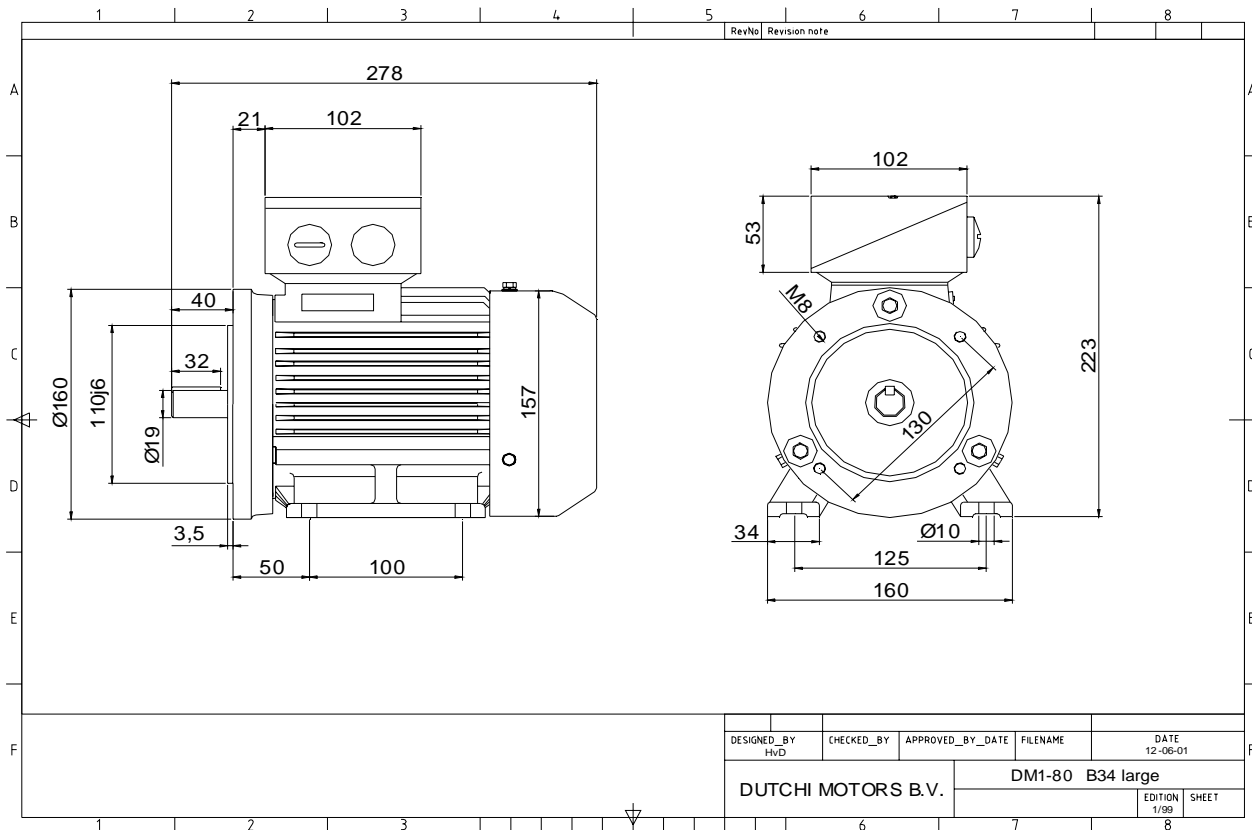

Specification **IEC 60034-1**
 Manufacturer **Dutchi Motors B.V.**
 Motor type **DM1- 80 K6**
 Rated power **0,37** kW **S1** duty
 Speed **900** r.p.m
 Voltage **230 / 400** V
 Frequency **50** Hz
 Connection **Δ / Y**
 Amps full load **2,03 / 1,17** A
 Amps no-load(400V) **1,00** A
 Enclosure **IP 55**
 Insulation Class **F (temp. rise B (80 K))**

Max. coolant temp. **40°C**
 Max. altitude **1.000** mtr, above sea level
 Comment **3 x PTC 150°C**
 Cable entries **2 x M25x1,5 + 1 x M20x1,5 (ptc)**

Feature **Cast-iron motor**
 Weight **17,0** kg
 Catalog no. **11726037D**
 Warranty **12~18 months**

Efficiency class **N/A**
 Load data 100% 75% 50% 25%
 Efficiency **62,9 60,4 55,7 38,2** %
 Power factor **0,72 0,61 0,51 0,35**

Sound pressure level (1m) **44,0** dB(A)
 Resistance R20 (open) **23,85** Ω
 Resistance R20 **Y 47,69** Ω

Full load torque **3,93** Nm
 DOL Starting torque vs FL torque **1,99**
 DOL Pull up torque vs FL torque **1,47**
 DOL Pull out torque vs FL torque **2,78**
 Star-Delta Starting torque vs FL torque **Y - motor**
 Star-Delta Pull up torque vs FL torque **Y - motor**
 Star-Delta Pull out torque vs FL torque **Y - motor**
 DOL Starting current vs FL current **3,50**
 Star Delta Starting current vs FL current **Y - motor**
 Rotor Inertia **0,0016** kgm²

Bearing DE **6204 - ZZ**
 Bearing NDE **6204 - ZZ**

Extras / Options :

WI	Change	date	sign.
Dutchi Motors B.V.		Description	date
P.O. Box 5390		Drawing made by :	19-04-04
NL-6802 EJ ARNHEM			
Tel : +31-(0)26 - 3541 600		dutchi.motors@dutchi.nl	
Fax : +31-(0)26 - 3541 650		www.dutchi.com	

Power is our commodity, the world is our market !

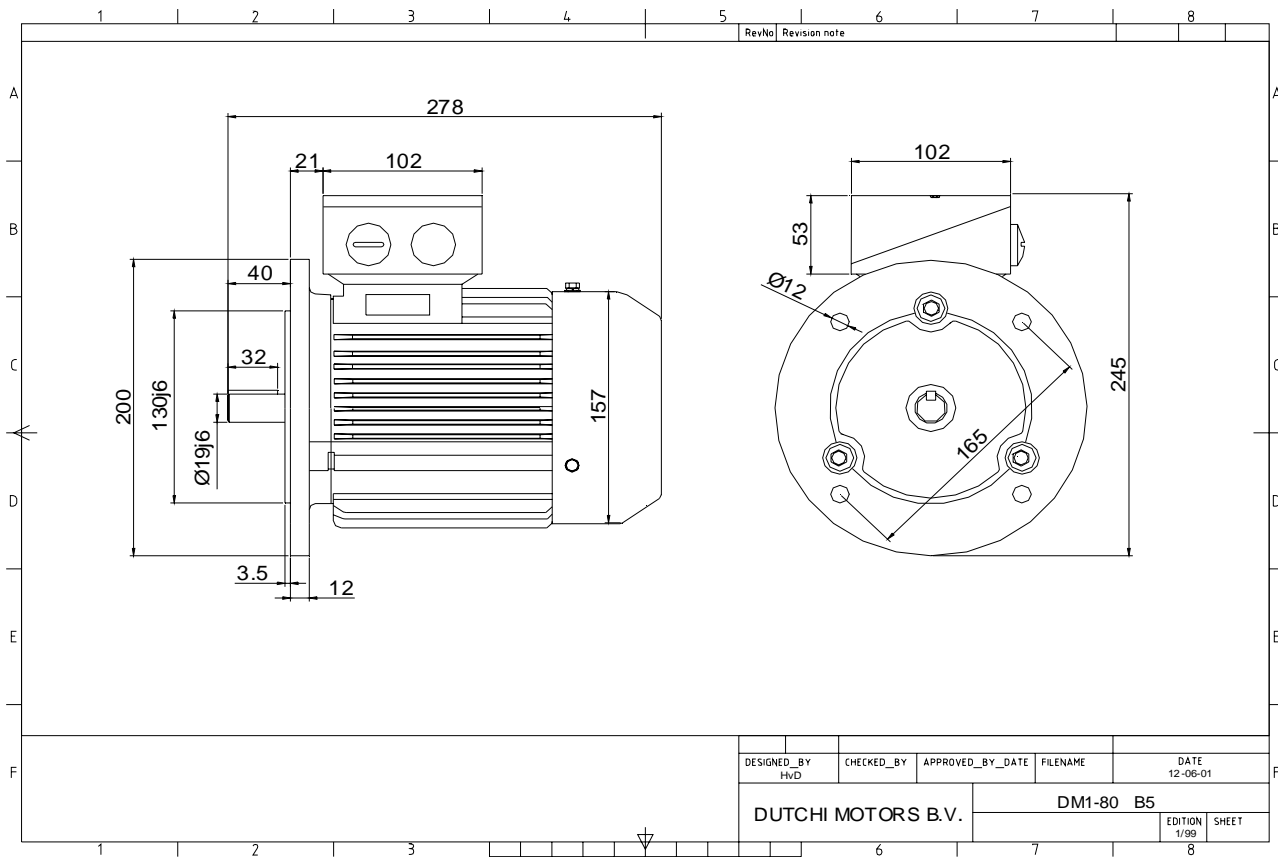

Specification	IEC 60034-1
Manufacturer	Dutchi Motors B.V.
Motor type	DM1- 80 K6
Rated power	0,37 kW S1 duty
Speed	900 r.p.m
Voltage	230 / 400 V
Frequency	50 Hz
Connection	Δ / Y
Amps full load	2,03 / 1,17 A
Amps no-load(400V)	1,00 A
Enclosure	IP 55
Insulation Class	F (temp. rise B (80 K))
Max. coolant temp.	40°C
Max. altitude	1.000 mtr, above sea level
Comment	3 x PTC 150°C
Cable entries	2 x M25x1,5 + 1 x M20x1,5 (ptc)
Feature	Cast-iron motor
Weight	17,0 kg
Catalog no.	11226037D
Warranty	12~18 months

Efficiency class	N/A			
Load data	100%	75%	50%	25%
Efficiency	62,9	60,4	55,7	38,2 %
Power factor	0,72	0,61	0,51	0,35
Sound pressure level (1m)				44,0 dB(A)
Resistance R20 (open)				23,85 Ω
Resistance R20	Y		47,69 Ω	
Full load torque				3,93 Nm
DOL Starting torque vs FL torque				1,99
DOL Pull up torque vs FL torque				1,47
DOL Pull out torque vs FL torque				2,78
Star-Delta Starting torque vs FL torque				Y - motor
Star-Delta Pull up torque vs FL torque				Y - motor
Star-Delta Pull out torque vs FL torque				Y - motor
DOL Starting current vs FL current				3,50
Star Delta Starting current vs FL current				Y - motor
Rotor Inertia				0,0016 kgm ²
Bearing DE				6204 - ZZ
Bearing NDE				6204 - ZZ

Extras / Options :

WI	Change	date	sign.
Dutchi Motors B.V. P.O. Box 5390 NL-6802 EJ ARNHEM Tel : +31-(0)26 - 3541 600 Fax : +31-(0)26 - 3541 650		Discription Drawing made by :	date 19-04-04 sign. HvD
		dutchi.motors@dutchi.nl www.dutchi.com	

Power is our commodity, the world is our market !

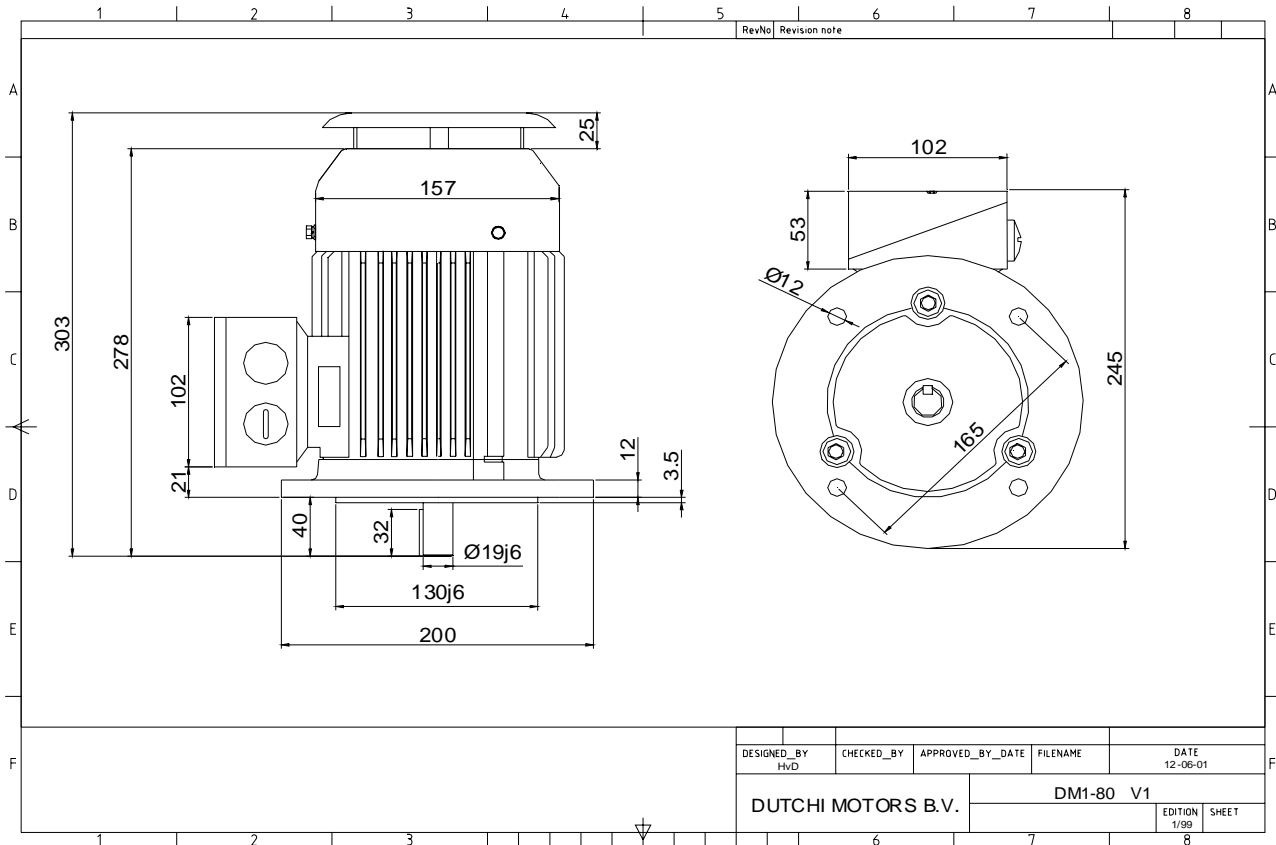

Specification	IEC 60034-1
Manufacturer	Dutchi Motors B.V.
Motor type	DM1- 80 K6
Rated power	0,37 kW S1 duty
Speed	900 r.p.m
Voltage	230 / 400 V
Frequency	50 Hz
Connection	Δ / Y
Amps full load	2,03 / 1,17 A
Amps no-load(400V)	1,00 A
Enclosure	IP 55
Insulation Class	F (temp. rise B (80 K))
Max. coolant temp.	40°C
Max. altitude	1.000 mtr, above sea level
Comment	3 x PTC 150°C
Cable entries	2 x M25x1,5 + 1 x M20x1,5 (ptc)
Feature	Cast-iron motor
Weight	17,0 kg
Catalog no.	11026037D
Warranty	12~18 months

Efficiency class	N/A			
Load data	100%	75%	50%	25%
Efficiency	62,9	60,4	55,7	38,2 %
Power factor	0,72	0,61	0,51	0,35
Sound pressure level (1m)				44,0 dB(A)
Resistance R20 (open)				23,85 Ω
Resistance R20	Y		47,69 Ω	
Full load torque				3,93 Nm
DOL Starting torque vs FL torque				1,99
DOL Pull up torque vs FL torque				1,47
DOL Pull out torque vs FL torque				2,78
Star-Delta Starting torque vs FL torque				Y - motor
Star-Delta Pull up torque vs FL torque				Y - motor
Star-Delta Pull out torque vs FL torque				Y - motor
DOL Starting current vs FL current				3,50
Star Delta Starting current vs FL current				Y - motor
Rotor Inertia				0,0016 kgm ²
Bearing DE				6204 - ZZ
Bearing NDE				6204 - ZZ

Extras / Options :

WI	Change	date	sign.
Dutchi Motors B.V. P.O. Box 5390 NL-6802 EJ ARNHEM Tel : +31-(0)26 - 3541 600 Fax : +31-(0)26 - 3541 650		Discription Drawing made by :	date 19-04-04
dutchi.motors@dutchi.nl www.dutchi.com		sign. HvD	

Power is our commodity, the world is our market !

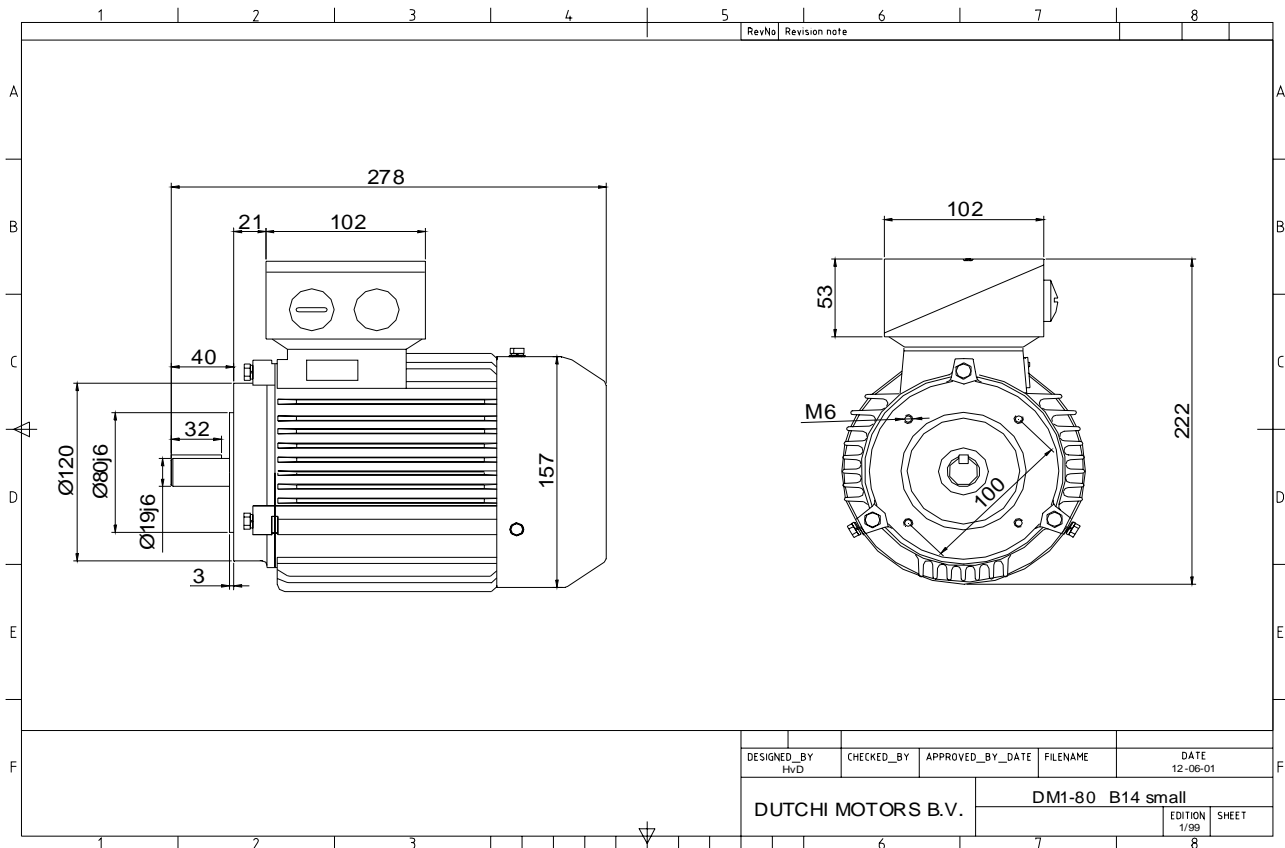

Specification **IEC 60034-1**
 Manufacturer **Dutchi Motors B.V.**
 Motor type **DM1- 80 K6**
 Rated power **0,37** kW **S1** duty
 Speed **900** r.p.m
 Voltage **230 / 400** V
 Frequency **50** Hz
 Connection **Δ / Y**
 Amps full load **2,03 / 1,17** A
 Amps no-load(400V) **1,00** A
 Enclosure **IP 55**
 Insulation Class **F (temp. rise B (80 K))**

Max. coolant temp. **40°C**
 Max. altitude **1.000** mtr, above sea level
 Comment **3 x PTC 150°C**
 Cable entries **2 x M25x1,5 + 1 x M20x1,5 (ptc)**

Feature **Cast-iron motor**
 Weight **17,0** kg
 Catalog no. **11326037D**
 Warranty **12~18 months**

Efficiency class **N/A**
 Load data 100% 75% 50% 25%
 Efficiency **62,9 60,4 55,7 38,2** %
 Power factor **0,72 0,61 0,51 0,35**

Sound pressure level (1m) **44,0** dB(A)
 Resistance R20 (open) **23,85** Ω
 Resistance R20 **Y 47,69** Ω

Full load torque **3,93** Nm
 DOL Starting torque vs FL torque **1,99**
 DOL Pull up torque vs FL torque **1,47**
 DOL Pull out torque vs FL torque **2,78**
 Star-Delta Starting torque vs FL torque **Y - motor**
 Star-Delta Pull up torque vs FL torque **Y - motor**
 Star-Delta Pull out torque vs FL torque **Y - motor**
 DOL Starting current vs FL current **3,50**
 Star Delta Starting current vs FL current **Y - motor**
 Rotor Inertia **0,0016** kgm²

Bearing DE **6204 - ZZ**
 Bearing NDE **6204 - ZZ**

Extras / Options :

WI	Change	date	sign.
Dutchi Motors B.V.		Description	date
P.O. Box 5390		Drawing made by :	19-04-04
NL-6802 EJ ARNHEM			
Tel : +31-(0)26 - 3541 600		dutchi.motors@dutchi.nl	
Fax : +31-(0)26 - 3541 650		www.dutchi.com	

Power is our commodity, the world is our market !

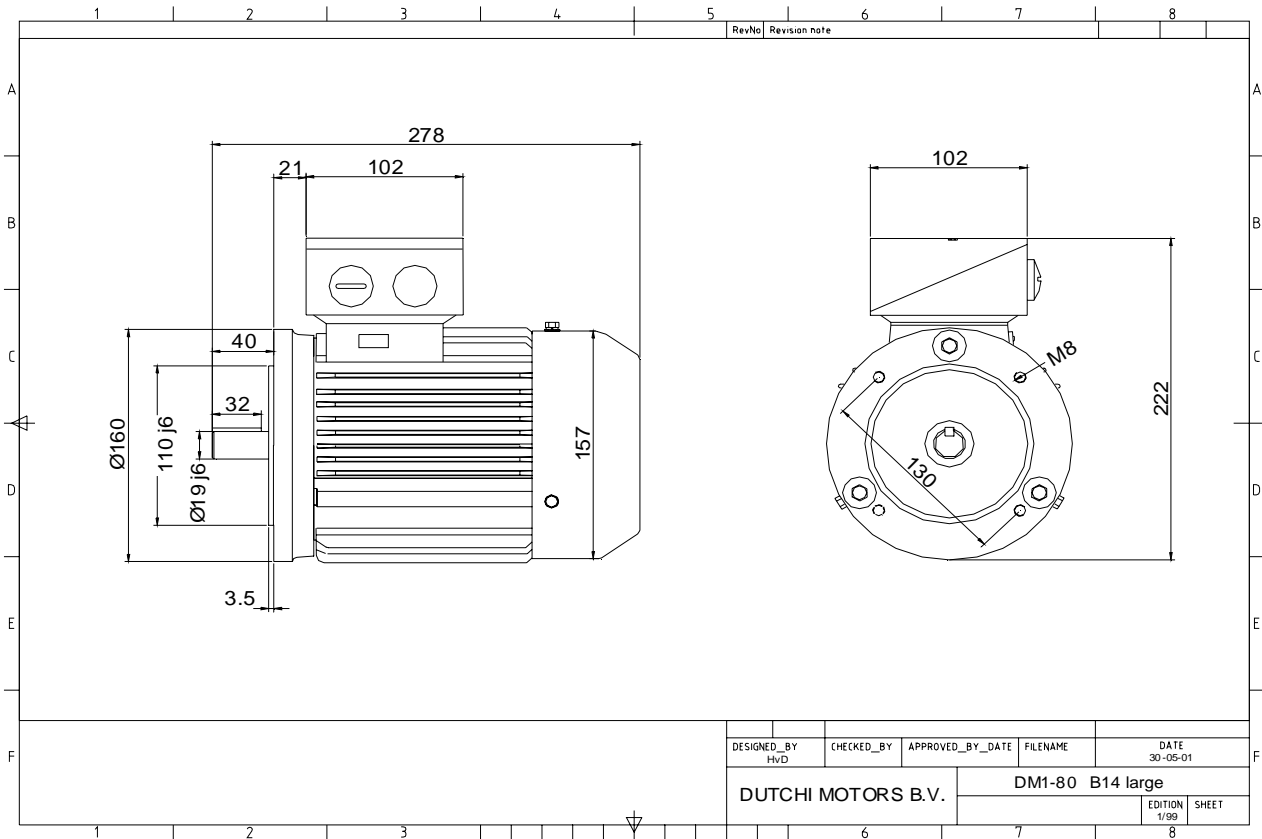

Specification **IEC 60034-1**
 Manufacturer **Dutchi Motors B.V.**
 Motor type **DM1- 80 K6**
 Rated power **0,37** kW **S1** duty
 Speed **900** r.p.m
 Voltage **230 / 400** V
 Frequency **50** Hz
 Connection **Δ / Y**
 Amps full load **2,03 / 1,17** A
 Amps no-load(400V) **1,00** A
 Enclosure **IP 55**
 Insulation Class **F (temp. rise B (80 K))**

Max. coolant temp. **40°C**
 Max. altitude **1.000** mtr, above sea level
 Comment **3 x PTC 150°C**
 Cable entries **2 x M25x1,5 + 1 x M20x1,5 (ptc)**

Feature **Cast-iron motor**
 Weight **17,0** kg
 Catalog no. **11426037D**
 Warranty **12~18 months**

Efficiency class **N/A**
 Load data 100% 75% 50% 25%
 Efficiency **62,9 60,4 55,7 38,2** %
 Power factor **0,72 0,61 0,51 0,35**

Sound pressure level (1m) **44,0** dB(A)
 Resistance R20 (open) **23,85** Ω
 Resistance R20 **Y 47,69** Ω

Full load torque **3,93** Nm
 DOL Starting torque vs FL torque **1,99**
 DOL Pull up torque vs FL torque **1,47**
 DOL Pull out torque vs FL torque **2,78**
 Star-Delta Starting torque vs FL torque **Y - motor**
 Star-Delta Pull up torque vs FL torque **Y - motor**
 Star-Delta Pull out torque vs FL torque **Y - motor**
 DOL Starting current vs FL current **3,50**
 Star Delta Starting current vs FL current **Y - motor**
 Rotor Inertia **0,0016** kgm2

Bearing DE **6204 - ZZ**
 Bearing NDE **6204 - ZZ**

Extras / Options :

WI	Change	date	sign.
Dutchi Motors B.V. P.O. Box 5390 NL-6802 EJ ARNHEM Tel : +31-(0)26 - 3541 600 Fax : +31-(0)26 - 3541 650		Discription Drawing made by :	date 19-04-04 sign. HvD
dutchi.motors@dutchi.nl www.dutchi.com			