

Power is our commodity, the world is our market !

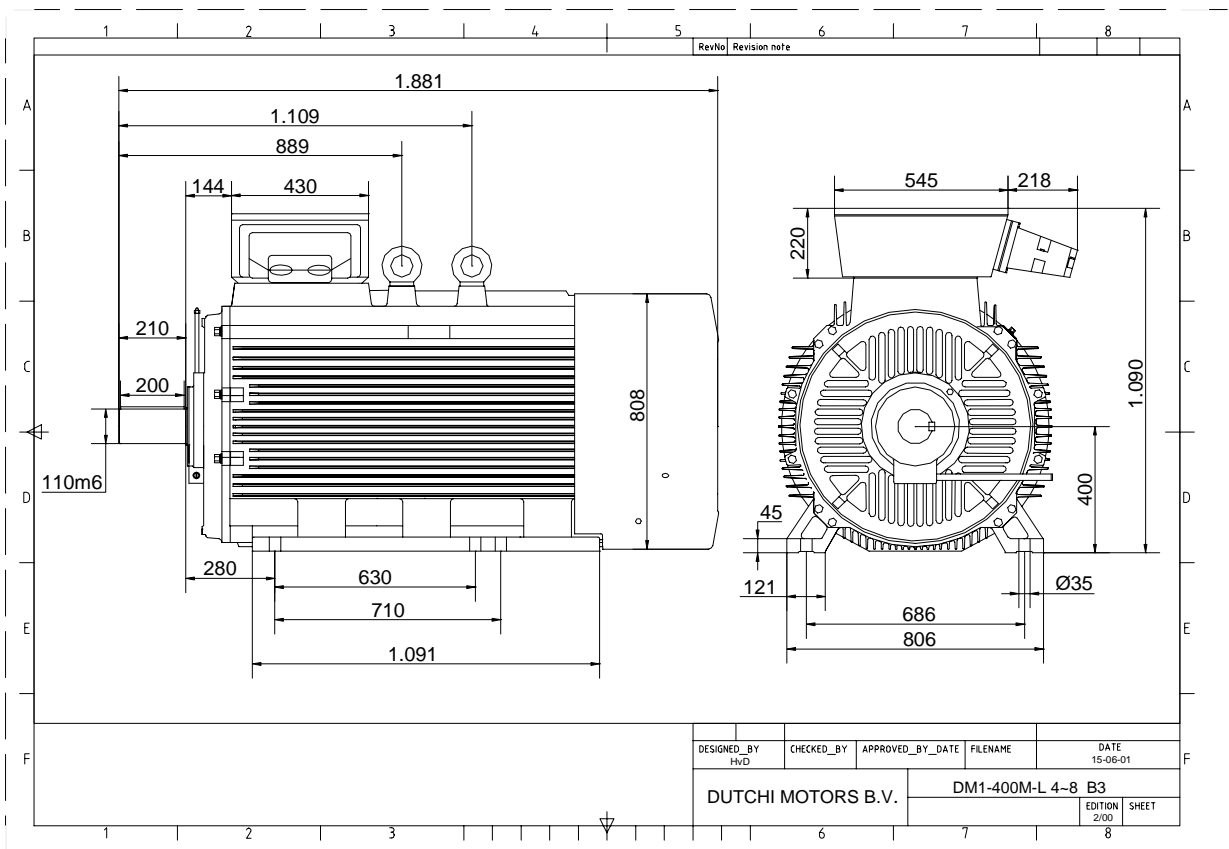

Specification	IEC 60034-1
Manufacturer	Dutchi Motors B.V.
Motor type	DM1- 400 LX6
Rated power	450 kW S1 duty
Speed	990 r.p.m
Voltage	400 / 690 V
Frequency	50 Hz
Connection	Δ / Y
Amps full load	759 / 438 A
Amps no-load(400V)	232 A
Enclosure	IP 55
Insulation Class	F (temp. rise F)
Max. coolant temp.	40°C
Max. altitude	1.000 mtr, above sea level
Comment	3 x PTC 150°C
Cable entries	2 x Ø 100 mm + 1 x M20x1,5 (ptc)
Feature	Cast-iron motor
Weight	3870 kg
Catalog no.	11136E80D
Warranty	12~18 months

Efficiency class	N/A			
Load data	100%	75%	50%	25%
Efficiency	95,8	95,4	94,1	89,9 %
Power factor	0,89	0,87	0,82	0,72
Sound pressure level (1m)	77,7 dB(A)			
Resistance R20 (open)	0,00362 Ω			
Resistance R20	Δ	0,00241 Ω		
Full load torque	4341 Nm			
DOL Starting torque vs FL torque	1,03			
DOL Pull up torque vs FL torque	1,07			
DOL Pull out torque vs FL torque	3,23			
Star-Delta Starting torque vs FL torque	0,32			
Star-Delta Pull up torque vs FL torque	0,33			
Star-Delta Pull out torque vs FL torque	1,01			
DOL Starting current vs FL current	6,46			
Star Delta Starting current vs FL current	2,02			
Rotor Inertia	22,00 kgm ²			
Bearing DE	6326 - C3 or NU326			
Bearing NDE	6326 - C3 (IM V1 7326B)			

Extras / Options :
Terminal box with extra 7 x M63x1,5

WI	Change	date	sign.
Dutchi Motors B.V. P.O. Box 5390 NL-6802 EJ ARNHEM Tel : +31-(0)26 - 3541 600 Fax : +31-(0)26 - 3541 650		Discription	date
		Drawing made by :	19-04-04
		dutchi.motors@dutchi.nl www.dutchi.com	

Power is our commodity, the world is our market !

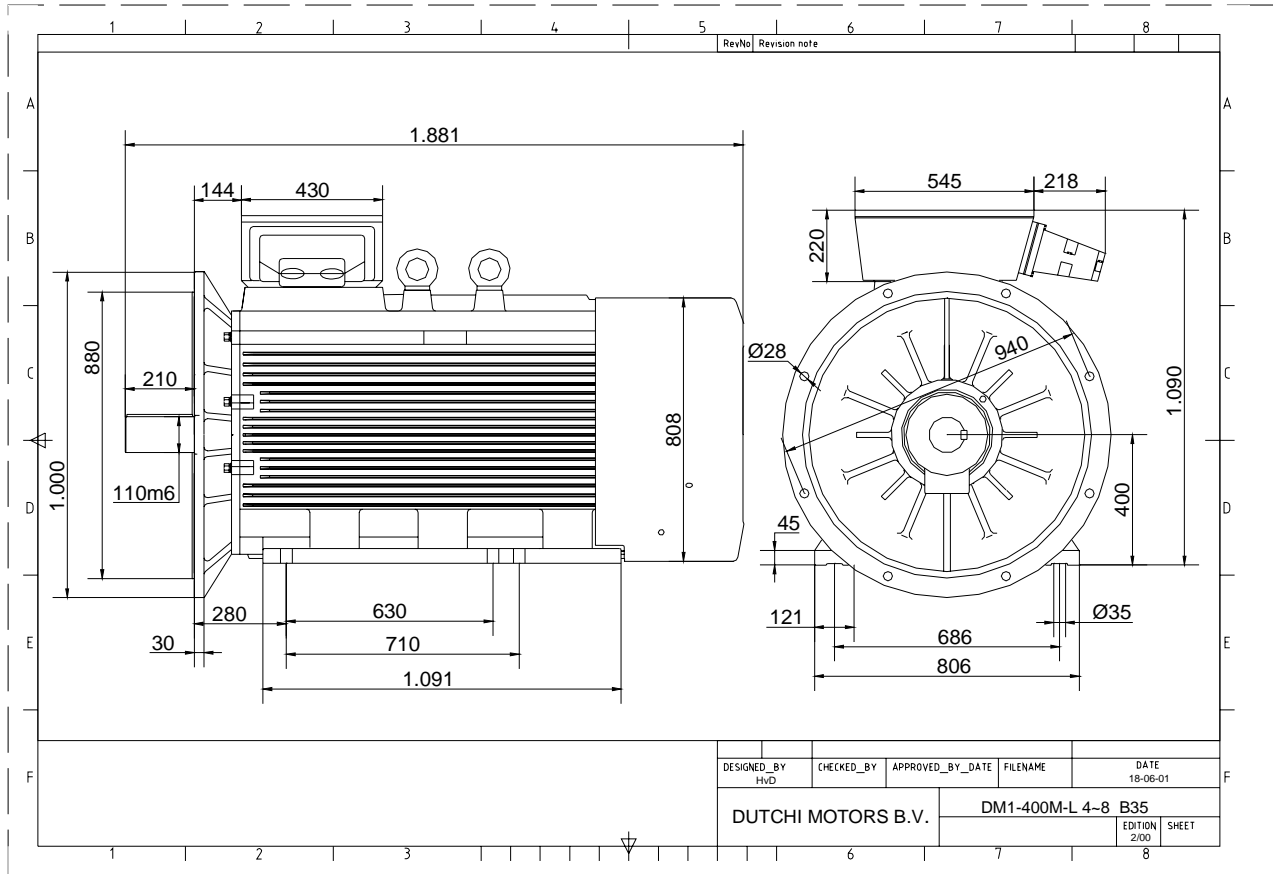

DESIGNED_BY HvD	CHECKED_BY	APPROVED_BY_DATE	FILENAME	DATE 18-06-01
DUTCHI MOTORS B.V.			DM1-400M-L 4-8 B35	EDITION 2/00
				SHEET

Specification	IEC 60034-1
Manufacturer	Dutchi Motors B.V.
Motor type	DM1- 400 LX6
Rated power	450 kW S1 duty
Speed	990 r.p.m
Voltage	400 / 690 V
Frequency	50 Hz
Connection	Δ / Y
Amps full load	759 / 438 A
Amps no-load(400V)	232 A
Enclosure	IP 55
Insulation Class	F (temp. rise F)
Max. coolant temp.	40°C
Max. altitude	1.000 mtr, above sea level
Comment	3 x PTC 150°C
Cable entries	2 x Ø 100 mm + 1 x M20x1,5 (ptc)
Feature	Cast-iron motor
Weight	3870 kg
Catalog no.	11536E80D
Warranty	12~18 months

Efficiency class	N/A			
Load data	100%	75%	50%	25%
Efficiency	95,8	95,4	94,1	89,9 %
Power factor	0,89	0,87	0,82	0,72
Sound pressure level (1m)				77,7 dB(A)
Resistance R20 (open)				0,00362 Ω
Resistance R20	Δ			0,00241 Ω
Full load torque				4341 Nm
DOL Starting torque vs FL torque				1,03
DOL Pull up torque vs FL torque				1,07
DOL Pull out torque vs FL torque				3,23
Star-Delta Starting torque vs FL torque				0,32
Star-Delta Pull up torque vs FL torque				0,33
Star-Delta Pull out torque vs FL torque				1,01
DOL Starting current vs FL current				6,46
Star Delta Starting current vs FL current				2,02
Rotor Inertia				22,00 kgm ²
Bearing DE				6326 - C3 or NU326
Bearing NDE				6326 - C3 (IM V1 7326B)

Extras / Options :
Terminal box with extra 7 x M63x1,5

WI	Change	date	sign.
Dutchi Motors B.V.		Discription	date
P.O. Box 5390		Drawing made by :	19-04-04
NL-6802 EJ ARNHEM			
Tel : +31-(0)26 - 3541 600		dutchi.motors@dutchi.nl	
Fax : +31-(0)26 - 3541 650		www.dutchi.com	

Power is our commodity, the world is our market !

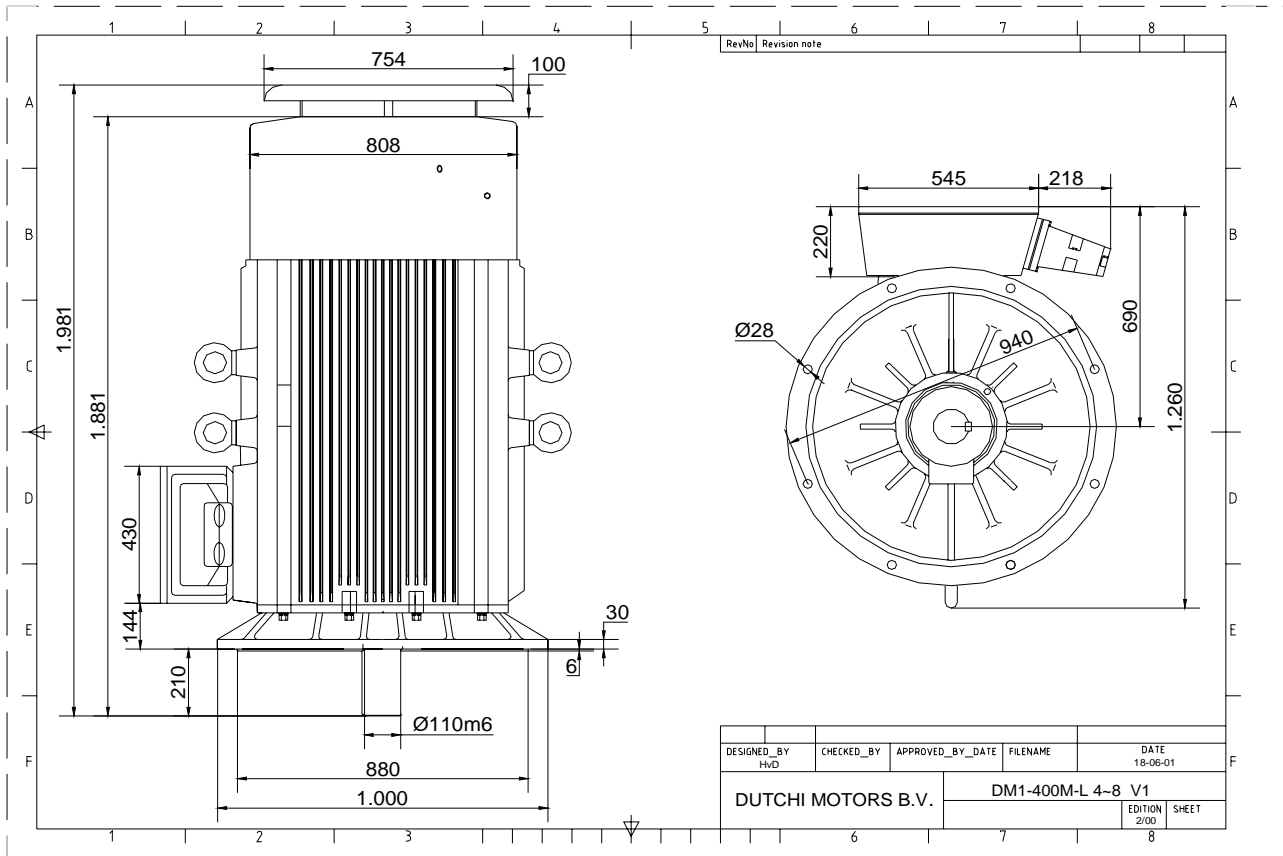

Specification	IEC 60034-1
Manufacturer	Dutchi Motors B.V.
Motor type	DM1- 400 LX6
Rated power	450 kW S1 duty
Speed	990 r.p.m
Voltage	400 / 690 V
Frequency	50 Hz
Connection	Δ / Y
Amps full load	759 / 438 A
Amps no-load(400V)	232 A
Enclosure	IP 55
Insulation Class	F (temp. rise F)
Max. coolant temp.	40°C
Max. altitude	1.000 mtr, above sea level
Comment	3 x PTC 150°C
Cable entries	2 x Ø 100 mm + 1 x M20x1,5 (ptc)
Feature	Cast-iron motor
Weight	3870 kg
Catalog no.	11036E80D
Warranty	12~18 months

Efficiency class	N/A			
Load data	100%	75%	50%	25%
Efficiency	95,8	95,4	94,1	89,9 %
Power factor	0,89	0,87	0,82	0,72
Sound pressure level (1m)	77,7 dB(A)			
Resistance R20 (open)	0,00362 Ω			
Resistance R20	Δ 0,00241 Ω			
Full load torque	4341 Nm			
DOL Starting torque vs FL torque	1,03			
DOL Pull up torque vs FL torque	1,07			
DOL Pull out torque vs FL torque	3,23			
Star-Delta Starting torque vs FL torque	0,32			
Star-Delta Pull up torque vs FL torque	0,33			
Star-Delta Pull out torque vs FL torque	1,01			
DOL Starting current vs FL current	6,46			
Star Delta Starting current vs FL current	2,02			
Rotor Inertia	22,00 kgm ²			
Bearing DE	6326 - C3 or NU326			
Bearing NDE	6326 - C3 (IM V1 7326B)			

Extras / Options :
Terminal box with extra 7 x M63x1,5

WI	Change	date	sign.
Dutchi Motors B.V.		Discription	date
P.O. Box 5390		Drawing made by :	19-04-04
NL-6802 EJ ARNHEM			
Tel : +31-(0)26 - 3541 600		dutchi.motors@dutchi.nl	
Fax : +31-(0)26 - 3541 650		www.dutchi.com	