

Power is our commodity, the world is our market !

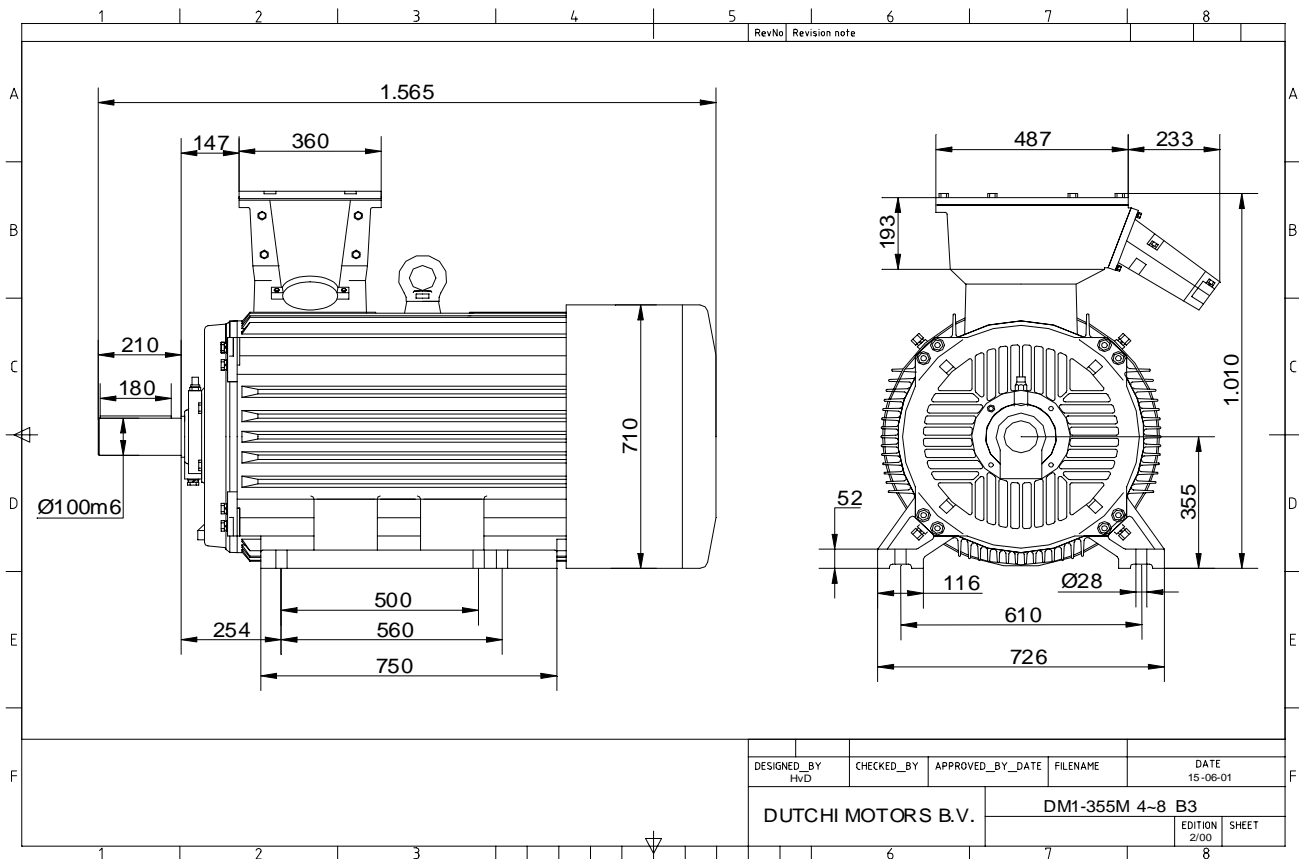

Specification	<b>IEC 60034-1</b>
Manufacturer	<b>Dutchi Motors B.V.</b>
Motor type	<b>DM1- 355 MX6</b>
Rated power	<b>180</b> kW <b>S1</b> duty
Speed	<b>990</b> r.p.m
Voltage	<b>400 / 690</b> V
Frequency	<b>50</b> Hz
Connection	<b>Δ / Y</b>
Amps full load	<b>300 / 173</b> A
Amps no-load(400V)	<b>67,40</b> A
Enclosure	<b>IP 55</b>
Insulation Class	<b>F (temp. rise B (80 K))</b>
Max. coolant temp.	<b>40°C</b>
Max. altitude	<b>1.000</b> mtr, above sea level
Comment	<b>3 x PTC 150°C</b>
Cable entries	<b>2 x Ø 70 mm + 1 x M20x1,5 (ptc)</b>
Feature	<b>Cast-iron motor</b>
Weight	<b>1770</b> kg
Catalog no.	<b>11136B80D</b>
Warranty	<b>12~18 months</b>

Efficiency class	<b>N/A</b>			
Load data	100%	75%	50%	25%
Efficiency	<b>95,3</b>	<b>95,0</b>	<b>93,9</b>	<b>89,9</b> %
Power factor	<b>0,91</b>	<b>0,90</b>	<b>0,86</b>	<b>0,71</b>
Sound pressure level (1m)				<b>72,6</b> dB(A)
Resistance R20 (open)				<b>0,0150</b> Ω
Resistance R20	<b>Δ</b>			<b>0,0100</b> Ω
Full load torque				<b>1736,36</b> Nm
DOL Starting torque vs FL torque				<b>1,72</b>
DOL Pull up torque vs FL torque				<b>1,40</b>
DOL Pull out torque vs FL torque				<b>3,41</b>
Star-Delta Starting torque vs FL torque				<b>0,54</b>
Star-Delta Pull up torque vs FL torque				<b>0,44</b>
Star-Delta Pull out torque vs FL torque				<b>1,07</b>
DOL Starting current vs FL current				<b>7,27</b>
Star Delta Starting current vs FL current				<b>2,27</b>
Rotor Inertia				<b>9,520</b> kgm <sup>2</sup>
Bearing DE				<b>6322 - C3 or NU322</b>
Bearing NDE				<b>6322 - C3 (IM V1 7322B)</b>

WI	Change	date	sign.
<b>Dutchi Motors B.V.</b> P.O. Box 5390 NL-6802 EJ ARNHEM Tel : +31-(0)26 - 3541 600 Fax : +31-(0)26 - 3541 650		Discription Drawing made by :	date 27-04-04 sign. HVD
dutchi.motors@dutchi.nl www.dutchi.com			

Power is our commodity, the world is our market !

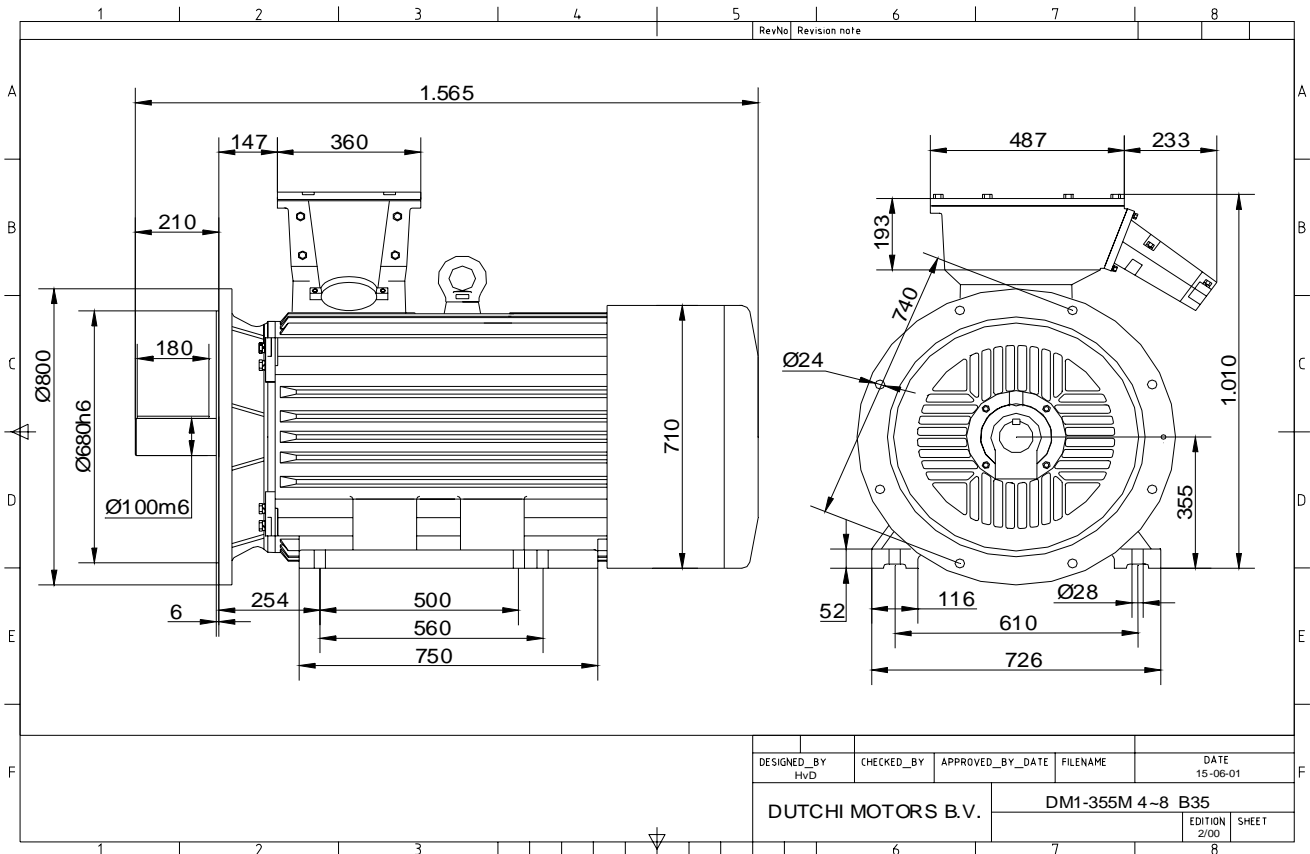

Specification **IEC 60034-1**  
 Manufacturer **Dutchi Motors B.V.**  
 Motor type **DM1- 355 MX6**  
 Rated power **180** kW **S1** duty  
 Speed **990** r.p.m  
 Voltage **400 / 690** V  
 Frequency **50** Hz  
 Connection **Δ / Y**  
 Amps full load **300 / 173** A  
 Amps no-load(400V) **67,40** A  
 Enclosure **IP 55**  
 Insulation Class **F (temp. rise B (80 K))**

Max. coolant temp. **40°C**  
 Max. altitude **1.000** mtr, above sea level  
 Comment **3 x PTC 150°C**  
 Cable entries **2 x Ø 70 mm + 1 x M20x1,5 (ptc)**

Feature **Cast-iron motor**  
 Weight **1770** kg  
 Catalog no. **11536B80D**  
 Warranty **12~18 months**

Efficiency class **N/A**  
 Load data 100% 75% 50% 25%  
 Efficiency **95,3 95,0 93,9 89,9** %  
 Power factor **0,91 0,90 0,86 0,71**

Sound pressure level (1m) **72,6** dB(A)  
 Resistance R20 (open) **0,0150** Ω  
 Resistance R20 **Δ 0,0100** Ω

Full load torque **1736,36** Nm  
 DOL Starting torque vs FL torque **1,72**  
 DOL Pull up torque vs FL torque **1,40**  
 DOL Pull out torque vs FL torque **3,41**  
 Star-Delta Starting torque vs FL torque **0,54**  
 Star-Delta Pull up torque vs FL torque **0,44**  
 Star-Delta Pull out torque vs FL torque **1,07**  
 DOL Starting current vs FL current **7,27**  
 Star Delta Starting current vs FL current **2,27**  
 Rotor Inertia **9,520** kgm<sup>2</sup>

Bearing DE **6322 - C3 or NU322**  
 Bearing NDE **6322 - C3 (IM V1 7322B)**

WI	Change	date	sign.
<b>Dutchi Motors B.V.</b> P.O. Box 5390 NL-6802 EJ ARNHEM Tel : +31-(0)26 - 3541 600 Fax : +31-(0)26 - 3541 650		Discription Drawing made by : 27-04-04	date sign. HvD
dutchi.motors@dutchi.nl www.dutchi.com			

Power is our commodity, the world is our market !

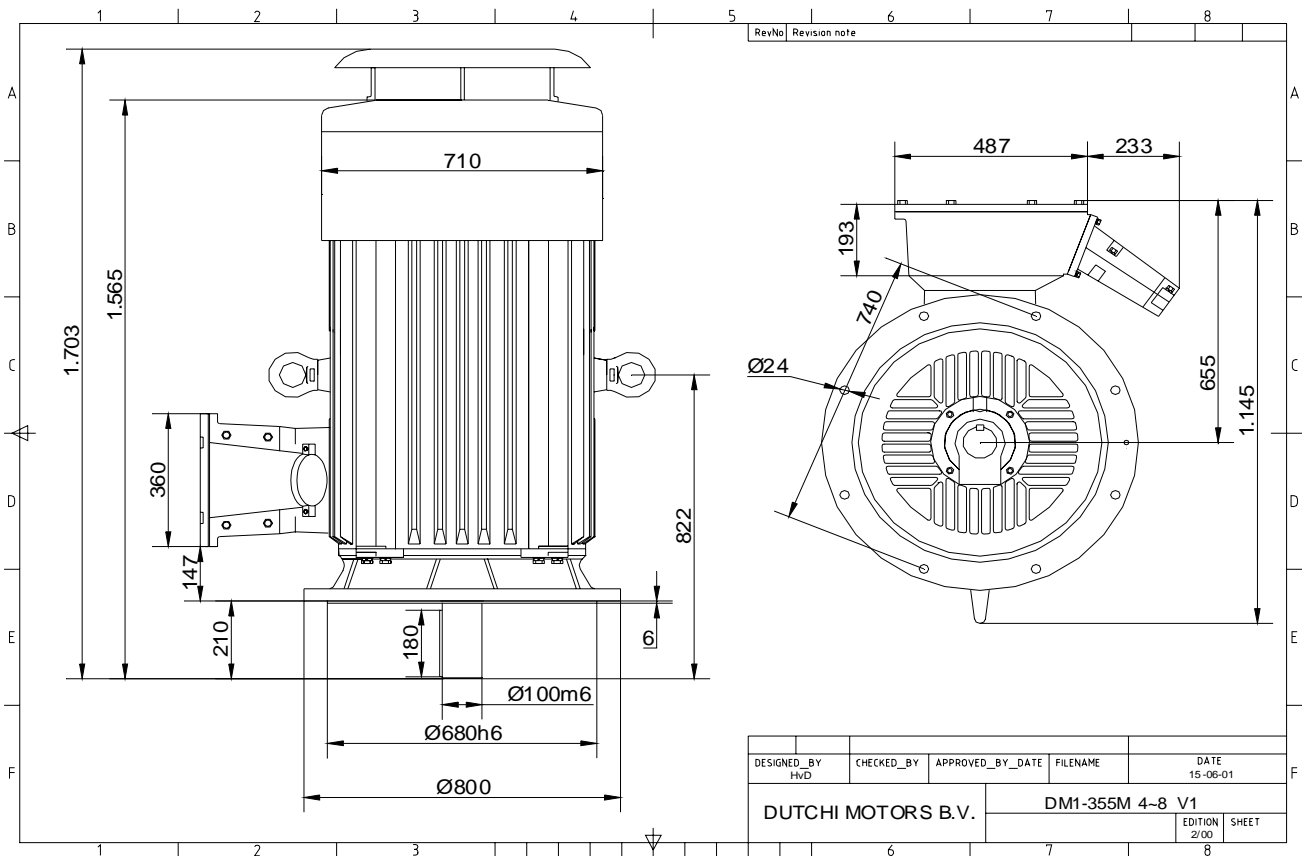

Specification **IEC 60034-1**  
 Manufacturer **Dutchi Motors B.V.**  
 Motor type **DM1- 355 MX6**  
 Rated power **180** kW **S1** duty  
 Speed **990** r.p.m  
 Voltage **400 / 690** V  
 Frequency **50** Hz  
 Connection **Δ / Y**  
 Amps full load **300 / 173** A  
 Amps no-load(400V) **67,40** A  
 Enclosure **IP 55**  
 Insulation Class **F (temp. rise B (80 K))**

Max. coolant temp. **40°C**  
 Max. altitude **1.000** mtr, above sea level  
 Comment **3 x PTC 150°C**  
 Cable entries **2 x Ø 70 mm + 1 x M20x1,5 (ptc)**

Feature **Cast-iron motor**  
 Weight **1770** kg  
 Catalog no. **11036B80D**  
 Warranty **12~18 months**

Efficiency class **N/A**  
 Load data 100% 75% 50% 25%  
 Efficiency **95,3 95,0 93,9 89,9** %  
 Power factor **0,91 0,90 0,86 0,71**

Sound pressure level (1m) **72,6** dB(A)  
 Resistance R20 (open) **0,0150** Ω  
 Resistance R20 **Δ 0,0100** Ω

Full load torque **1736,36** Nm  
 DOL Starting torque vs FL torque **1,72**  
 DOL Pull up torque vs FL torque **1,40**  
 DOL Pull out torque vs FL torque **3,41**  
 Star-Delta Starting torque vs FL torque **0,54**  
 Star-Delta Pull up torque vs FL torque **0,44**  
 Star-Delta Pull out torque vs FL torque **1,07**  
 DOL Starting current vs FL current **7,27**  
 Star Delta Starting current vs FL current **2,27**  
 Rotor Inertia **9,520** kgm<sup>2</sup>

Bearing DE **6322 - C3 or NU322**  
 Bearing NDE **6322 - C3 (IM V1 7322B)**

WI	Change	date	sign.
Dutchi Motors B.V.		Description	date
P.O. Box 5390		Drawing made by :	27-04-04
NL-6802 EJ ARNHEM			
Tel : +31-(0)26 - 3541 600		dutchi.motors@dutchi.nl	
Fax : +31-(0)26 - 3541 650		www.dutchi.com	