

Power is our commodity, the world is our market !

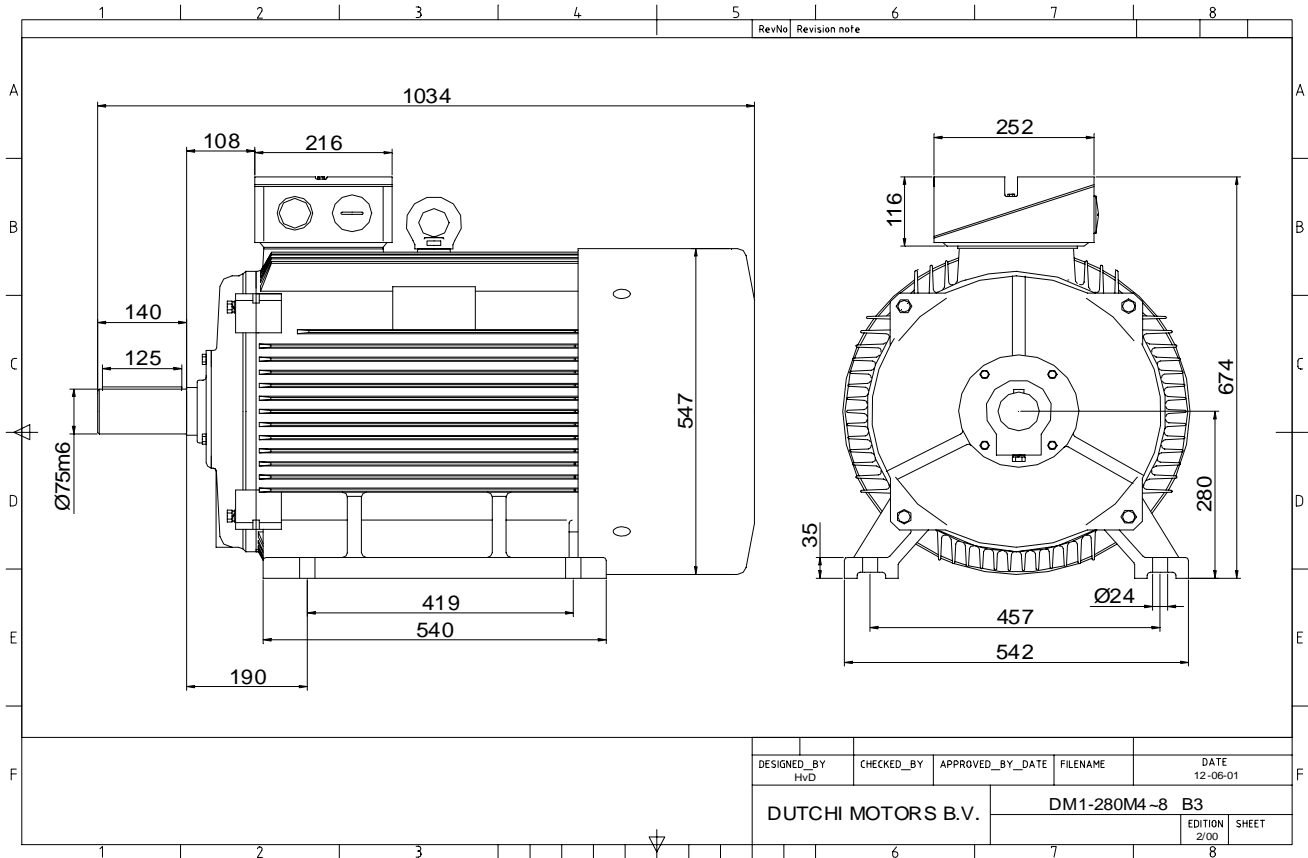

Specification **IEC 60034-1**
 Manufacturer **Dutchi Motors B.V.**
 Motor type **DM1- 280 M6**
 Rated power **55** kW **S1** duty
 Speed **985** r.p.m
 Voltage **400 / 690** V
 Frequency **50** Hz
 Connection **Δ / Y**
 Amps full load **96 / 55,7** A
 Amps no-load(400V) **27,70** A
 Enclosure **IP 55**
 Insulation Class **F (temp. rise B (80 K))**

Max. coolant temp. **40°C**
 Max. altitude **1.000** mtr, above sea level
 Comment **3 x PTC 150°C**
 Cable entries **2 x M63x1,5 + 1 x M20x1,5 (ptc)**

Feature **Cast-iron motor**
 Weight **540** kg
 Catalog no. **11136A55D**
 Warranty **12~18 months**

Efficiency class **N/A**
 Load data 100% 75% 50% 25%
 Efficiency **92,5 92,8 92,1 88,4** %
 Power factor **0,89 0,87 0,84 0,78**

Sound pressure level (1m) **70,2** dB(A)
 Resistance R20 (open) **0,1356** Ω
 Resistance R20 **Δ 0,0904** Ω

Full load torque **533** Nm
 DOL Starting torque vs FL torque **2,11**
 DOL Pull up torque vs FL torque **1,52**
 DOL Pull out torque vs FL torque **3,00**
 Star-Delta Starting torque vs FL torque **0,66**
 Star-Delta Pull up torque vs FL torque **0,48**
 Star-Delta Pull out torque vs FL torque **0,94**
 DOL Starting current vs FL current **7,01**
 Star Delta Starting current vs FL current **2,19**
 Rotor Inertia **1,5980** kgm²

Bearing DE **6317 - C3 or NU317**
 Bearing NDE **6317 - C3**

WI	Change	date	sign.
Dutchi Motors B.V. P.O. Box 5390 NL-6802 EJ ARNHEM Tel : +31-(0)26 - 3541 600 Fax : +31-(0)26 - 3541 650		Description	date
		Drawing made by :	27-04-04
		dutchi.motors@dutchi.nl www.dutchi.com	

Power is our commodity, the world is our market !

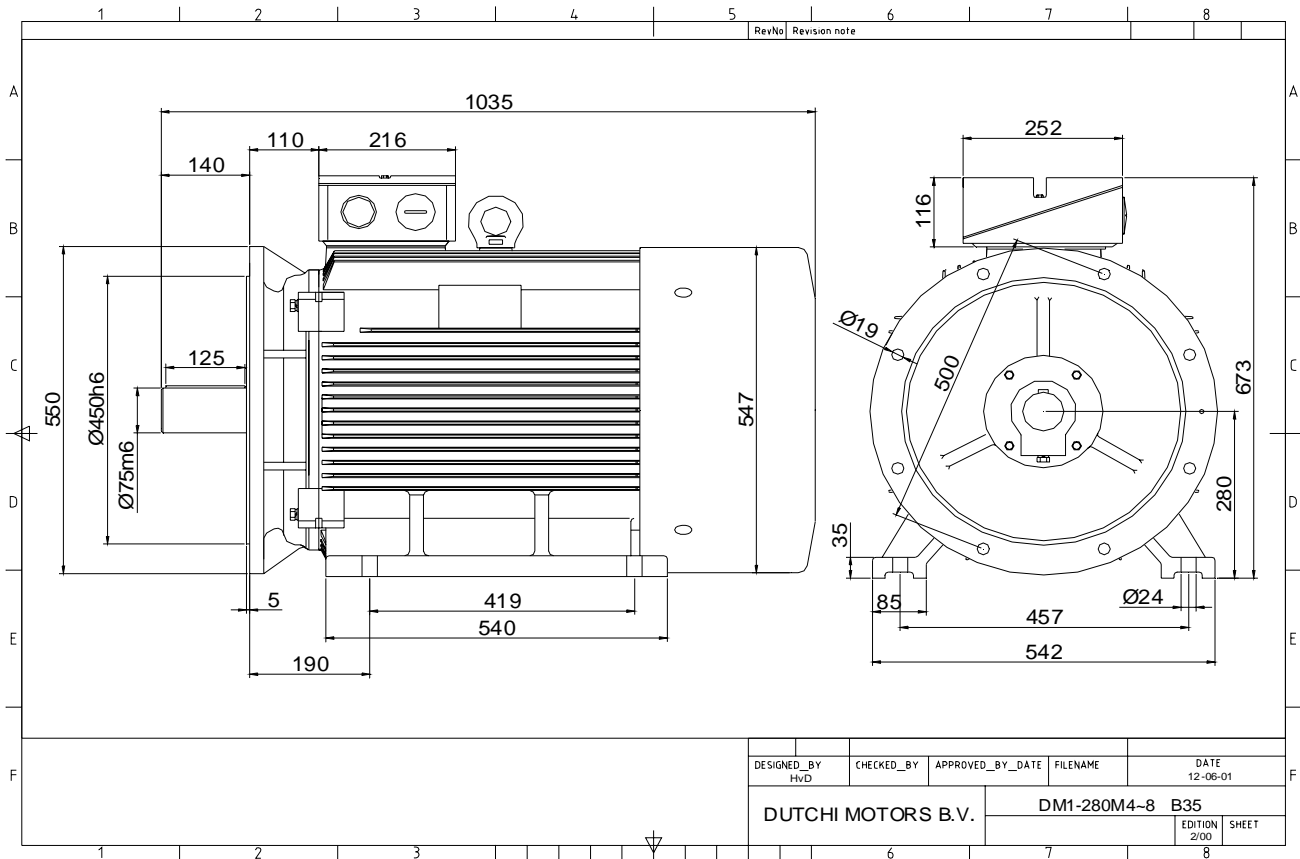

DESIGNED_BY HvD	CHECKED_BY	APPROVED_BY_DATE	FILENAME	DATE 12-06-01
DUTCHI MOTORS B.V.			DM1-280M4-8	B35
			EDITION 2/00	SHEET

Specification	IEC 60034-1
Manufacturer	Dutchi Motors B.V.
Motor type	DM1- 280 M6
Rated power	55 kW S1 duty
Speed	985 r.p.m
Voltage	400 / 690 V
Frequency	50 Hz
Connection	Δ / Y
Amps full load	96 / 55,7 A
Amps no-load(400V)	27,70 A
Enclosure	IP 55
Insulation Class	F (temp. rise B (80 K))
Max. coolant temp.	40°C
Max. altitude	1.000 mtr, above sea level
Comment	3 x PTC 150°C
Cable entries	2 x M63x1,5 + 1 x M20x1,5 (ptc)
Feature	Cast-iron motor
Weight	540 kg
Catalog no.	11536A55D
Warranty	12~18 months

Efficiency class	N/A			
Load data	100%	75%	50%	25%
Efficiency	92,5	92,8	92,1	88,4 %
Power factor	0,89	0,87	0,84	0,78
Sound pressure level (1m)				70,2 dB(A)
Resistance R20 (open)				0,1356 Ω
Resistance R20	Δ			0,0904 Ω
Full load torque				533 Nm
DOL Starting torque vs FL torque				2,11
DOL Pull up torque vs FL torque				1,52
DOL Pull out torque vs FL torque				3,00
Star-Delta Starting torque vs FL torque				0,66
Star-Delta Pull up torque vs FL torque				0,48
Star-Delta Pull out torque vs FL torque				0,94
DOL Starting current vs FL current				7,01
Star Delta Starting current vs FL current				2,19
Rotor Inertia				1,5980 kgm ²
Bearing DE				6317 - C3 or NU317
Bearing NDE				6317 - C3

WI	Change	date	sign.
Dutchi Motors B.V. P.O. Box 5390 NL-6802 EJ ARNHEM Tel : +31-(0)26 - 3541 600 Fax : +31-(0)26 - 3541 650		Discription Drawing made by :	date sign. HvD
		27-04-04	
		dutchi.motors@dutchi.nl www.dutchi.com	

Power is our commodity, the world is our market !

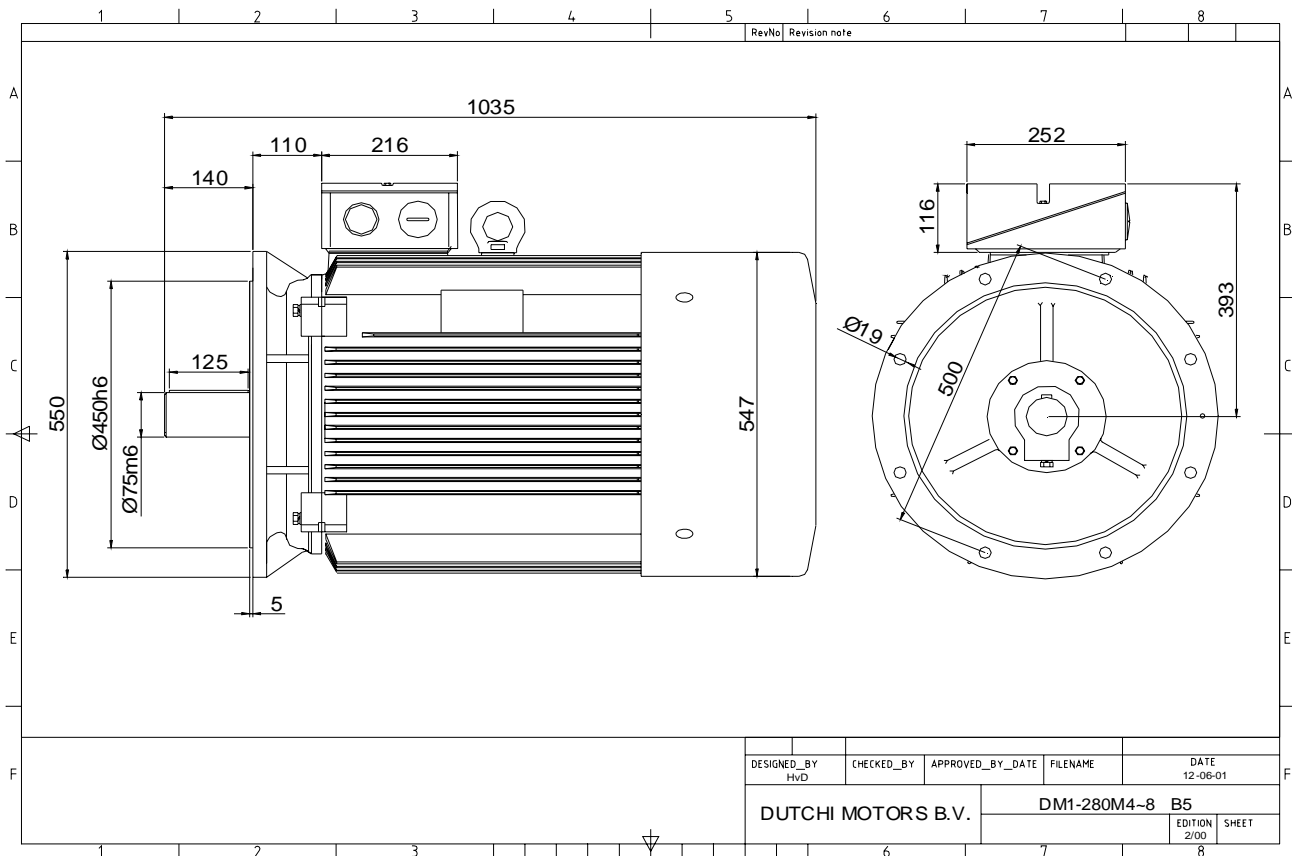

DESIGNED_BY HvD	CHECKED_BY	APPROVED_BY_DATE	FILENAME	DATE 12-06-01
DUTCHI MOTORS B.V.			DM1-280M4~8 B5	EDITION 2/00
				SHEET

Specification	IEC 60034-1
Manufacturer	Dutchi Motors B.V.
Motor type	DM1- 280 M6
Rated power	55 kW S1 duty
Speed	985 r.p.m
Voltage	400 / 690 V
Frequency	50 Hz
Connection	Δ / Y
Amps full load	96 / 55,7 A
Amps no-load(400V)	27,70 A
Enclosure	IP 55
Insulation Class	F (temp. rise B (80 K))
Max. coolant temp.	40°C
Max. altitude	1.000 mtr, above sea level
Comment	3 x PTC 150°C
Cable entries	2 x M63x1,5 + 1 x M20x1,5 (ptc)
Feature	Cast-iron motor
Weight	540 kg
Catalog no.	11236A55D
Warranty	12~18 months

Efficiency class	N/A			
Load data	100%	75%	50%	25%
Efficiency	92,5	92,8	92,1	88,4 %
Power factor	0,89	0,87	0,84	0,78
Sound pressure level (1m)				70,2 dB(A)
Resistance R20 (open)				0,1356 Ω
Resistance R20	Δ			0,0904 Ω
Full load torque				533 Nm
DOL Starting torque vs FL torque				2,11
DOL Pull up torque vs FL torque				1,52
DOL Pull out torque vs FL torque				3,00
Star-Delta Starting torque vs FL torque				0,66
Star-Delta Pull up torque vs FL torque				0,48
Star-Delta Pull out torque vs FL torque				0,94
DOL Starting current vs FL current				7,01
Star Delta Starting current vs FL current				2,19
Rotor Inertia				1,5980 kgm ²
Bearing DE				6317 - C3 or NU317
Bearing NDE				6317 - C3

WI	Change	date	sign.
Dutchi Motors B.V. P.O. Box 5390 NL-6802 EJ ARNHEM Tel : +31-(0)26 - 3541 600 Fax : +31-(0)26 - 3541 650		Discription Drawing made by :	date 27-04-04 sign. HvD
		dutchi.motors@dutchi.nl www.dutchi.com	

Power is our commodity, the world is our market !

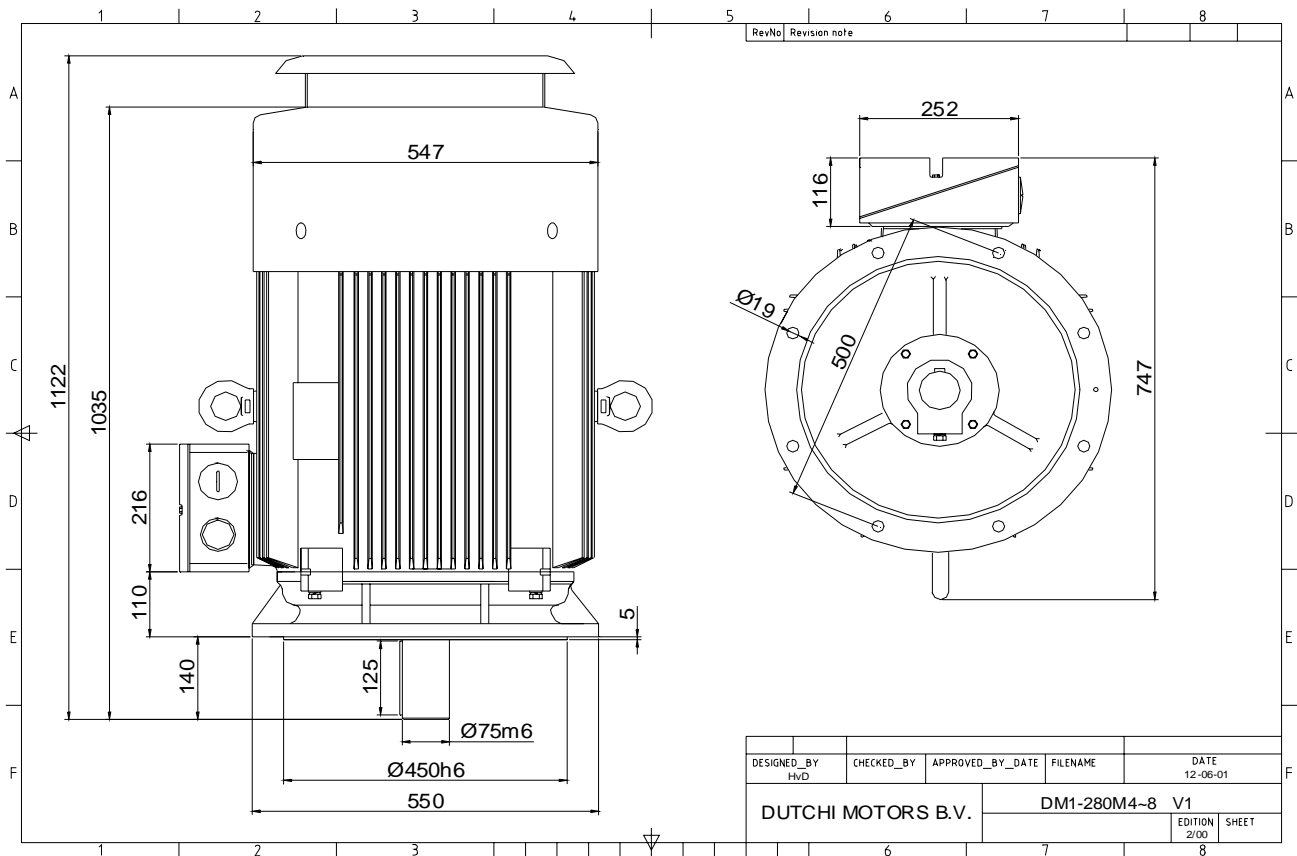

Specification **IEC 60034-1**
 Manufacturer **Dutchi Motors B.V.**
 Motor type **DM1- 280 M6**
 Rated power **55** kW **S1** duty
 Speed **985** r.p.m
 Voltage **400 / 690** V
 Frequency **50** Hz
 Connection **Δ / Y**
 Amps full load **96 / 55,7** A
 Amps no-load(400V) **27,70** A
 Enclosure **IP 55**
 Insulation Class **F (temp. rise B (80 K))**

Max. coolant temp. **40°C**
 Max. altitude **1.000** mtr, above sea level
 Comment **3 x PTC 150°C**
 Cable entries **2 x M63x1,5 + 1 x M20x1,5 (ptc)**

Feature **Cast-iron motor**
 Weight **540** kg
 Catalog no. **11036A55D**
 Warranty **12~18 months**

Efficiency class **N/A**
 Load data 100% 75% 50% 25%
 Efficiency **92,5 92,8 92,1 88,4** %
 Power factor **0,89 0,87 0,84 0,78**

Sound pressure level (1m) **70,2** dB(A)
 Resistance R20 (open) **0,1356** Ω
 Resistance R20 **Δ 0,0904** Ω

Full load torque **533** Nm
 DOL Starting torque vs FL torque **2,11**
 DOL Pull up torque vs FL torque **1,52**
 DOL Pull out torque vs FL torque **3,00**
 Star-Delta Starting torque vs FL torque **0,66**
 Star-Delta Pull up torque vs FL torque **0,48**
 Star-Delta Pull out torque vs FL torque **0,94**
 DOL Starting current vs FL current **7,01**
 Star Delta Starting current vs FL current **2,19**
 Rotor Inertia **1,5980** kgm2

Bearing DE **6317 - C3 or NU317**
 Bearing NDE **6317 - C3**

WI	Change	date	sign.
Dutchi Motors B.V.		Description	date
P.O. Box 5390		Drawing made by :	27-04-04
NL-6802 EJ ARNHEM			
Tel : +31-(0)26 - 3541 600		dutchi.motors@dutchi.nl	
Fax : +31-(0)26 - 3541 650		www.dutchi.com	