

Power is our commodity, the world is our market !

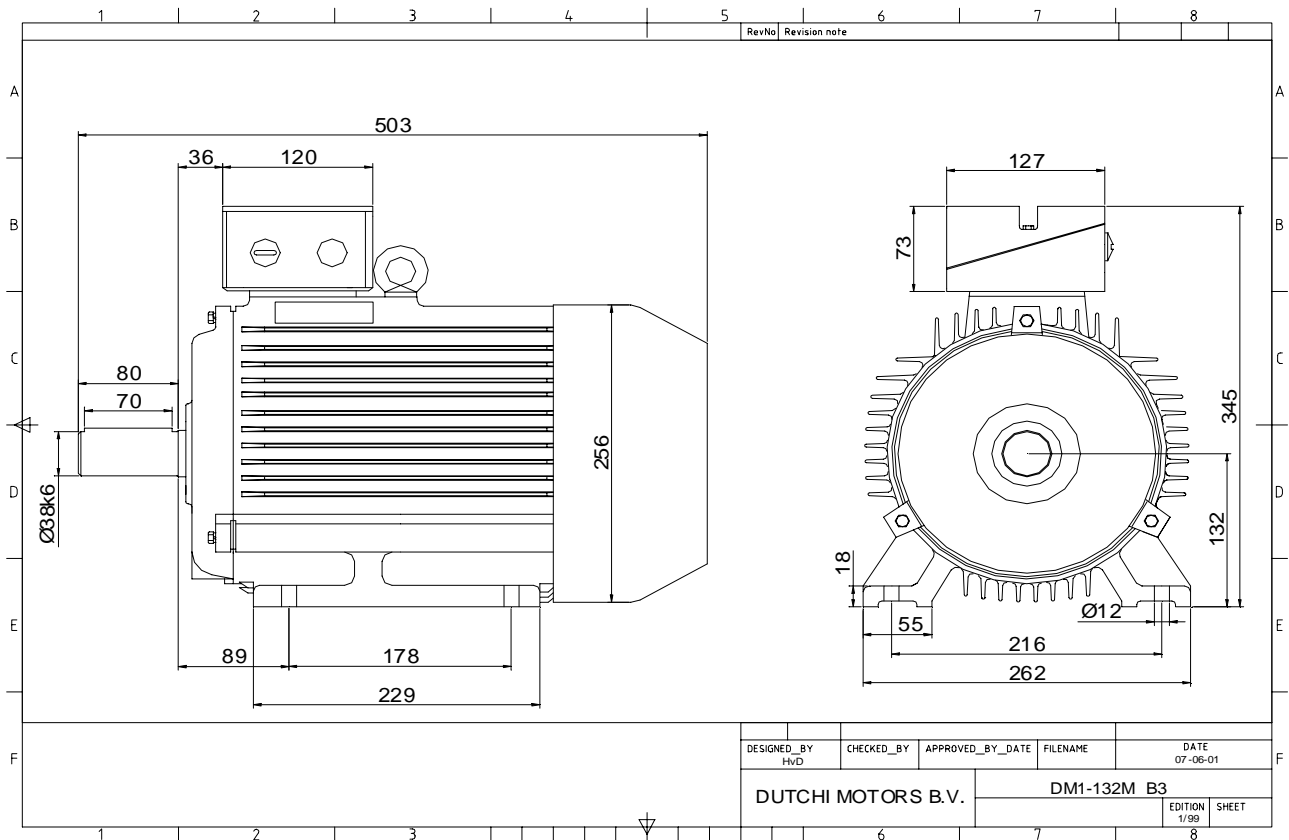

Specification	<b>IEC 60034-1</b>
Manufacturer	<b>Dutchi Motors B.V.</b>
Motor type	<b>DM1- 132 MX6</b>
Rated power	<b>5,5</b> kW <b>S1</b> duty
Speed	<b>975</b> r.p.m
Voltage	<b>400 / 690</b> V
Frequency	<b>50</b> Hz
Connection	<b>Δ / Y</b>
Amps full load	<b>12,00 / 6,93</b> A
Amps no-load(400V)	<b>7,30</b> A
Enclosure	<b>IP 55</b>
Insulation Class	<b>F (temp. rise B (80 K))</b>
Max. coolant temp.	<b>40°C</b>
Max. altitude	<b>1.000</b> mtr, above sea level
Comment	<b>3 x PTC 150°C</b>
Cable entries	<b>2 x M32x1,5 + 1 x M20x1,5 (ptc)</b>
Feature	<b>Cast-iron motor</b>
Weight	<b>75,0</b> kg
Catalog no.	<b>11136550D</b>
Warranty	<b>12~18 months</b>

Efficiency class	<b>N/A</b>			
Load data	100%	75%	50%	25%
Efficiency	<b>85,6</b>	<b>85,2</b>	<b>85,0</b>	<b>74,0</b> %
Power factor	<b>0,77</b>	<b>0,69</b>	<b>0,64</b>	<b>0,35</b>
Sound pressure level (1m)				<b>56,4</b> dB(A)
Resistance R20 (open)				<b>2,41</b> Ω
Resistance R20	<b>Δ</b>			<b>1,61</b> Ω
Full load torque				<b>53,87</b> Nm
DOL Starting torque vs FL torque				<b>2,05</b>
DOL Pull up torque vs FL torque				<b>1,70</b>
DOL Pull out torque vs FL torque				<b>4,04</b>
Star-Delta Starting torque vs FL torque				<b>0,64</b>
Star-Delta Pull up torque vs FL torque				<b>0,53</b>
Star-Delta Pull out torque vs FL torque				<b>1,26</b>
DOL Starting current vs FL current				<b>7,50</b>
Star Delta Starting current vs FL current				<b>2,34</b>
Rotor Inertia				<b>0,0431</b> kgm <sup>2</sup>
Bearing DE				<b>6308 - ZZ C3</b>
Bearing NDE				<b>6308 - ZZ C3</b>

WI	Change	date	sign.
<b>Dutchi Motors B.V.</b> P.O. Box 5390 NL-6802 EJ ARNHEM Tel : +31-(0)26 - 3541 600 Fax : +31-(0)26 - 3541 650		Discription Drawing made by :	date sign. HvD
dutchi.motors@dutchi.nl www.dutchi.com		19-04-04	

Power is our commodity, the world is our market !

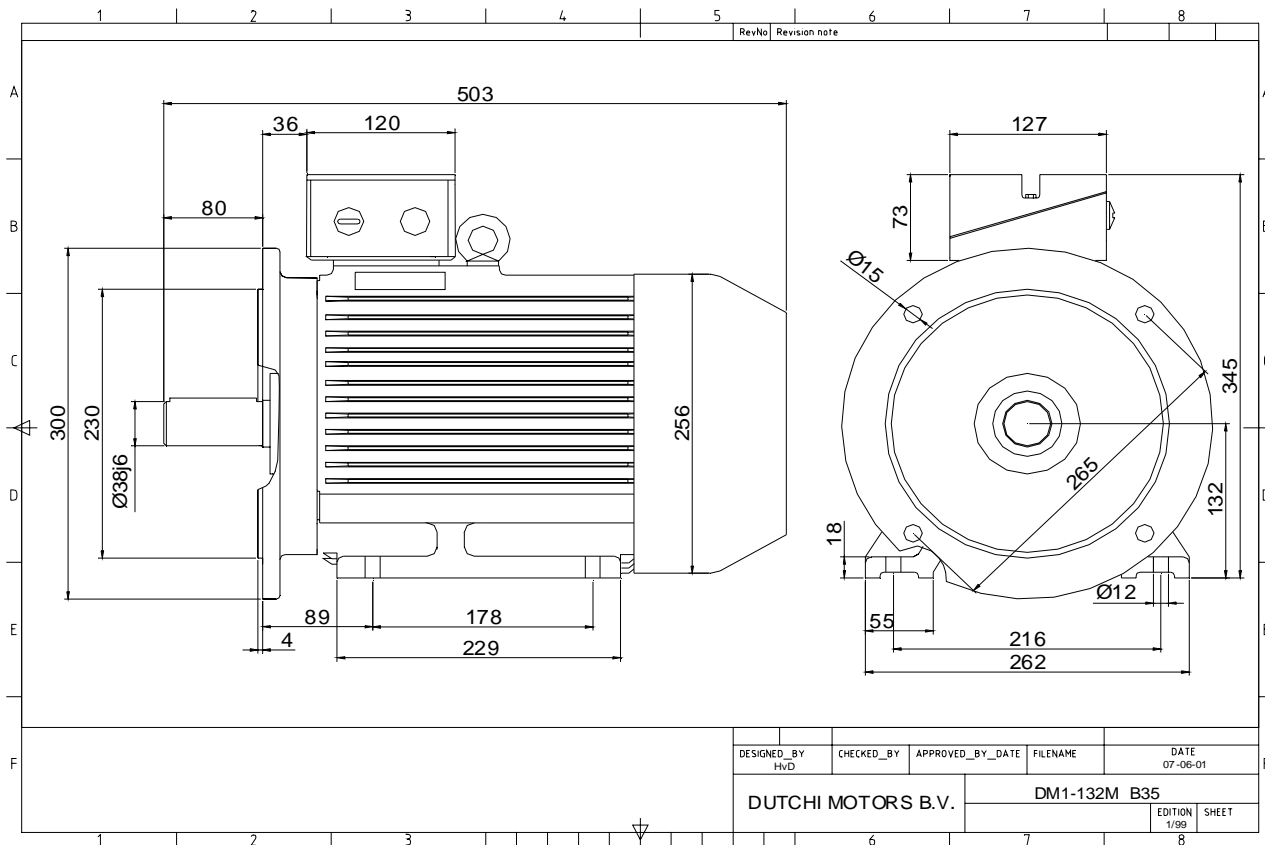

Specification **IEC 60034-1**  
 Manufacturer **Dutchi Motors B.V.**  
 Motor type **DM1- 132 MX6**  
 Rated power **5,5** kW **S1** duty  
 Speed **975** r.p.m  
 Voltage **400 / 690** V  
 Frequency **50** Hz  
 Connection **Δ / Y**  
 Amps full load **12,00 / 6,93** A  
 Amps no-load(400V) **7,30** A  
 Enclosure **IP 55**  
 Insulation Class **F (temp. rise B (80 K))**

Max. coolant temp. **40°C**  
 Max. altitude **1.000** mtr, above sea level  
 Comment **3 x PTC 150°C**  
 Cable entries **2 x M32x1,5 + 1 x M20x1,5 (ptc)**

Feature **Cast-iron motor**  
 Weight **75,0** kg  
 Catalog no. **11536550D**  
 Warranty **12~18 months**

Efficiency class **N/A**  
 Load data 100% 75% 50% 25%  
 Efficiency **85,6 85,2 85,0 74,0** %  
 Power factor **0,77 0,69 0,64 0,35**

Sound pressure level (1m) **56,4** dB(A)  
 Resistance R20 (open) **2,41** Ω  
 Resistance R20 **Δ 1,61** Ω

Full load torque **53,87** Nm  
 DOL Starting torque vs FL torque **2,05**  
 DOL Pull up torque vs FL torque **1,70**  
 DOL Pull out torque vs FL torque **4,04**  
 Star-Delta Starting torque vs FL torque **0,64**  
 Star-Delta Pull up torque vs FL torque **0,53**  
 Star-Delta Pull out torque vs FL torque **1,26**  
 DOL Starting current vs FL current **7,50**  
 Star Delta Starting current vs FL current **2,34**  
 Rotor Inertia **0,0431** kgm<sup>2</sup>

Bearing DE **6308 - ZZ C3**  
 Bearing NDE **6308 - ZZ C3**

WI	Change	date	sign.
Dutchi Motors B.V.		Description	sign.
P.O. Box 5390		date	HvD
NL-6802 EJ ARNHEM		Drawing made by :	19-04-04
Tel : +31-(0)26 - 3541 600		dutchi.motors@dutchi.nl	
Fax : +31-(0)26 - 3541 650		www.dutchi.com	

Power is our commodity, the world is our market !

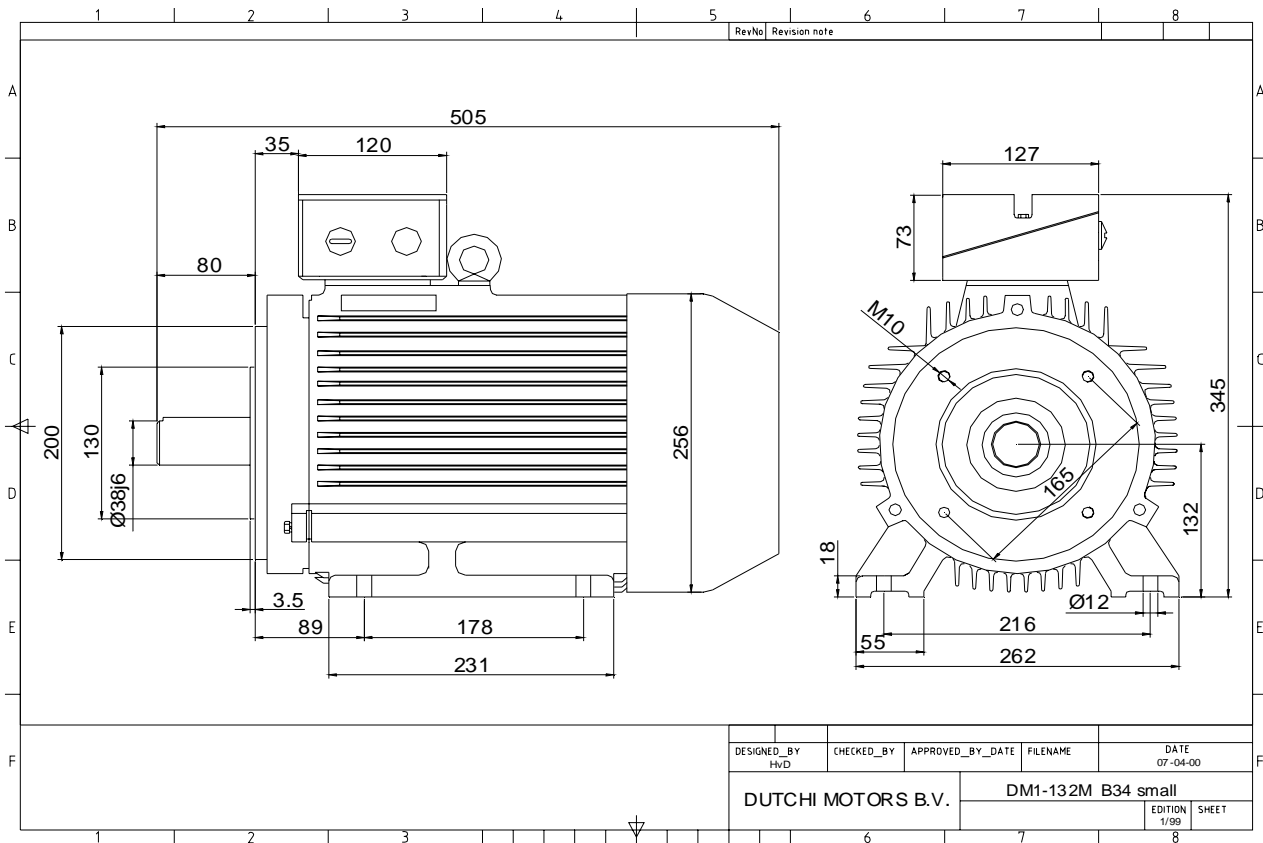

Specification **IEC 60034-1**  
 Manufacturer **Dutchi Motors B.V.**  
 Motor type **DM1- 132 MX6**  
 Rated power **5,5** kW **S1** duty  
 Speed **975** r.p.m  
 Voltage **400 / 690** V  
 Frequency **50** Hz  
 Connection **Δ / Y**  
 Amps full load **12,00 / 6,93** A  
 Amps no-load(400V) **7,30** A  
 Enclosure **IP 55**  
 Insulation Class **F (temp. rise B (80 K))**

Max. coolant temp. **40°C**  
 Max. altitude **1.000** mtr, above sea level  
 Comment **3 x PTC 150°C**  
 Cable entries **2 x M32x1,5 + 1 x M20x1,5 (ptc)**

Feature **Cast-iron motor**  
 Weight **75,0** kg  
 Catalog no. **11636550D**  
 Warranty **12~18 months**

Efficiency class **N/A**  
 Load data 100% 75% 50% 25%  
 Efficiency **85,6 85,2 85,0 74,0** %  
 Power factor **0,77 0,69 0,64 0,35**

Sound pressure level (1m) **56,4** dB(A)  
 Resistance R20 (open) **2,41** Ω  
 Resistance R20 **Δ 1,61** Ω

Full load torque **53,87** Nm  
 DOL Starting torque vs FL torque **2,05**  
 DOL Pull up torque vs FL torque **1,70**  
 DOL Pull out torque vs FL torque **4,04**  
 Star-Delta Starting torque vs FL torque **0,64**  
 Star-Delta Pull up torque vs FL torque **0,53**  
 Star-Delta Pull out torque vs FL torque **1,26**  
 DOL Starting current vs FL current **7,50**  
 Star Delta Starting current vs FL current **2,34**  
 Rotor Inertia **0,0431** kgm<sup>2</sup>

Bearing DE **6308 - ZZ C3**  
 Bearing NDE **6308 - ZZ C3**

WI	Change	date	sign.
<b>Dutchi Motors B.V.</b> P.O. Box 5390 NL-6802 EJ ARNHEM Tel : +31-(0)26 - 3541 600 Fax : +31-(0)26 - 3541 650		Discription	date
		Drawing made by :	19-04-04
		<b>dutchi.motors@dutchi.nl</b> <b>www.dutchi.com</b>	

Power is our commodity, the world is our market !

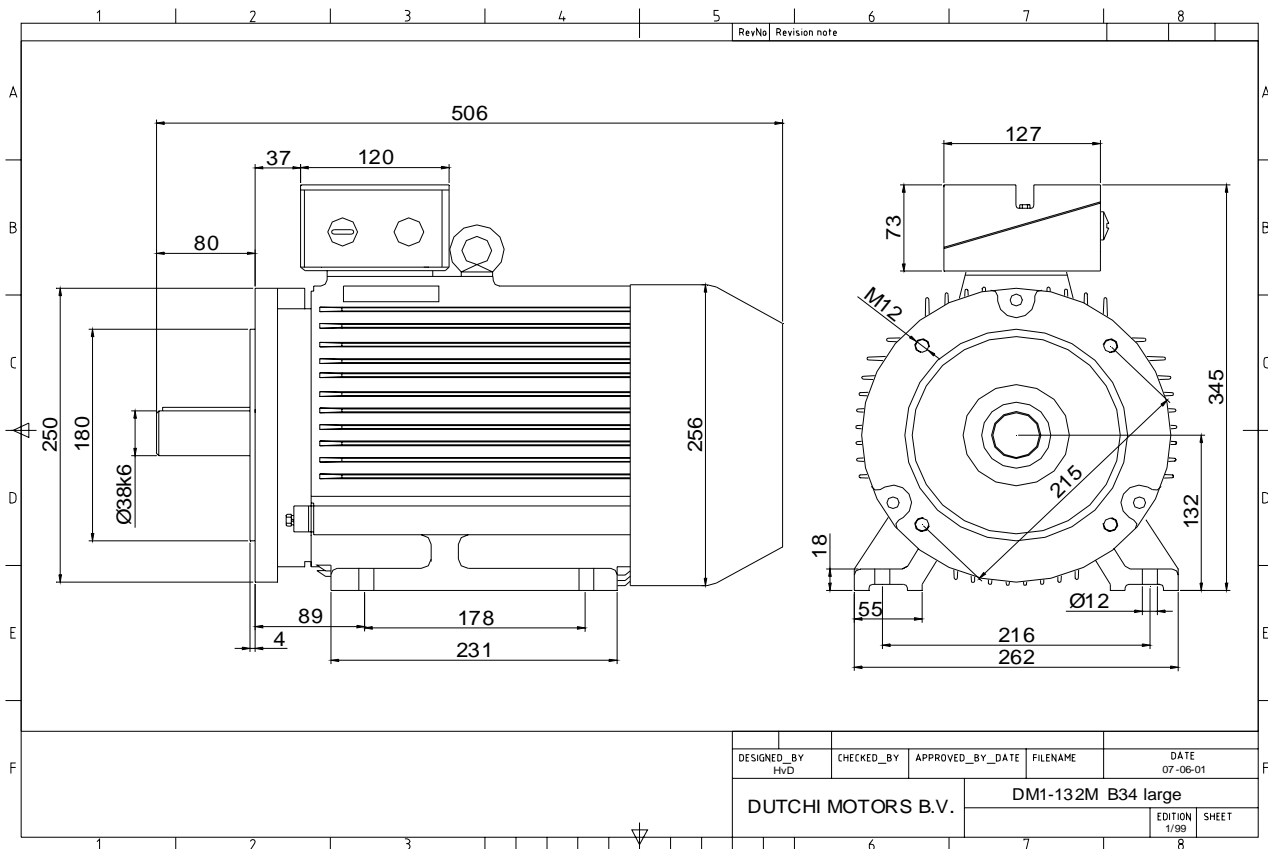

Specification **IEC 60034-1**  
 Manufacturer **Dutchi Motors B.V.**  
 Motor type **DM1- 132 MX6**  
 Rated power **5,5** kW **S1** duty  
 Speed **975** r.p.m  
 Voltage **400 / 690** V  
 Frequency **50** Hz  
 Connection **Δ / Y**  
 Amps full load **12,00 / 6,93** A  
 Amps no-load(400V) **7,30** A  
 Enclosure **IP 55**  
 Insulation Class **F (temp. rise B (80 K))**

Max. coolant temp. **40°C**  
 Max. altitude **1.000** mtr, above sea level  
 Comment **3 x PTC 150°C**  
 Cable entries **2 x M32x1,5 + 1 x M20x1,5 (ptc)**

Feature **Cast-iron motor**  
 Weight **75,0** kg  
 Catalog no. **11736550D**  
 Warranty **12~18 months**

Efficiency class **N/A**  
 Load data 100% 75% 50% 25%  
 Efficiency **85,6 85,2 85,0 74,0** %  
 Power factor **0,77 0,69 0,64 0,35**

Sound pressure level (1m) **56,4** dB(A)  
 Resistance R20 (open) **2,41** Ω  
 Resistance R20 **Δ 1,61** Ω

Full load torque **53,87** Nm  
 DOL Starting torque vs FL torque **2,05**  
 DOL Pull up torque vs FL torque **1,70**  
 DOL Pull out torque vs FL torque **4,04**  
 Star-Delta Starting torque vs FL torque **0,64**  
 Star-Delta Pull up torque vs FL torque **0,53**  
 Star-Delta Pull out torque vs FL torque **1,26**  
 DOL Starting current vs FL current **7,50**  
 Star Delta Starting current vs FL current **2,34**  
 Rotor Inertia **0,0431** kgm2

Bearing DE **6308 - ZZ C3**  
 Bearing NDE **6308 - ZZ C3**

WI	Change	date	sign.
<b>Dutchi Motors B.V.</b> P.O. Box 5390 NL-6802 EJ ARNHEM Tel : +31-(0)26 - 3541 600 Fax : +31-(0)26 - 3541 650		Discription Drawing made by : 19-04-04	date sign. HVD
		<b>dutchi.motors@dutchi.nl</b> <b>www.dutchi.com</b>	

Power is our commodity, the world is our market !

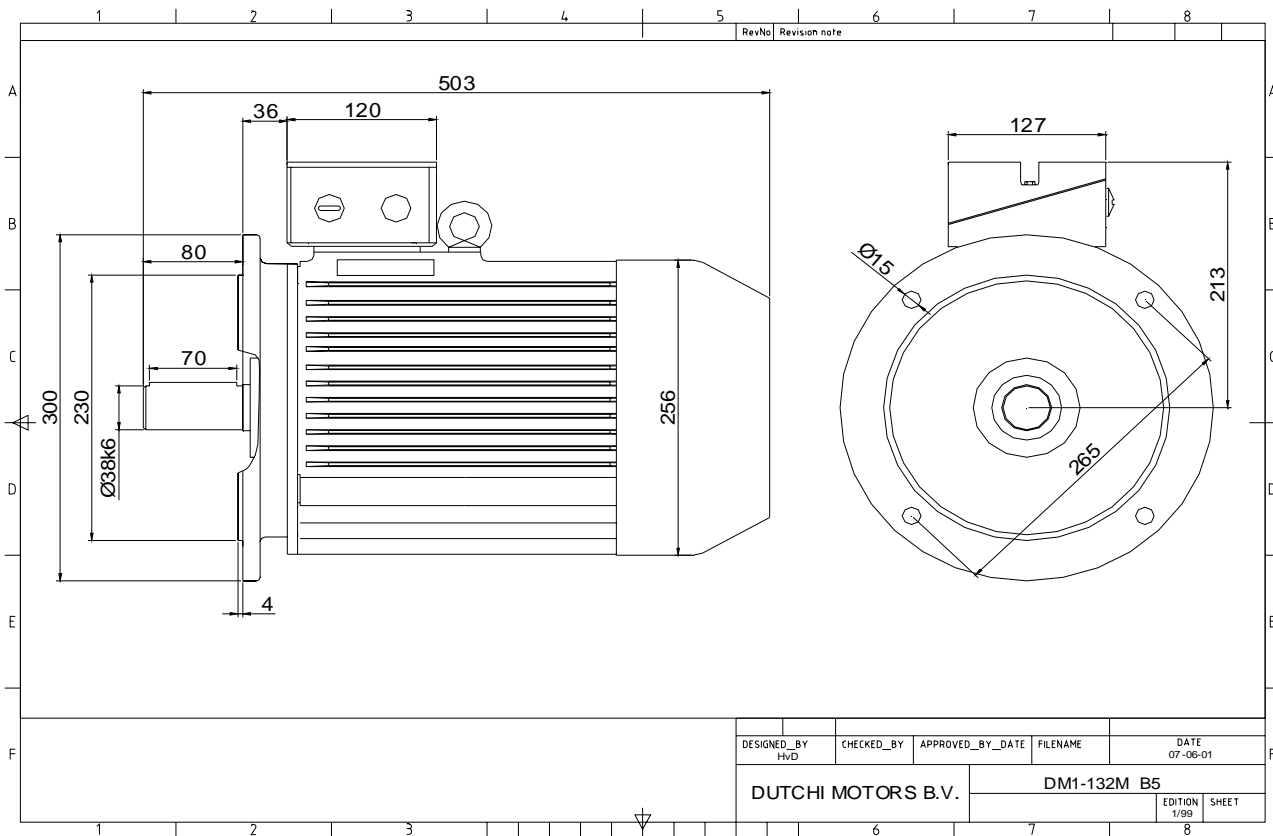

Specification	<b>IEC 60034-1</b>
Manufacturer	<b>Dutchi Motors B.V.</b>
Motor type	<b>DM1- 132 MX6</b>
Rated power	<b>5,5</b> kW <b>S1</b> duty
Speed	<b>975</b> r.p.m
Voltage	<b>400 / 690</b> V
Frequency	<b>50</b> Hz
Connection	<b>Δ / Y</b>
Amps full load	<b>12,00 / 6,93</b> A
Amps no-load(400V)	<b>7,30</b> A
Enclosure	<b>IP 55</b>
Insulation Class	<b>F (temp. rise B (80 K))</b>
Max. coolant temp.	<b>40°C</b>
Max. altitude	<b>1.000</b> mtr, above sea level
Comment	<b>3 x PTC 150°C</b>
Cable entries	<b>2 x M32x1,5 + 1 x M20x1,5 (ptc)</b>
Feature	<b>Cast-iron motor</b>
Weight	<b>75,0</b> kg
Catalog no.	<b>11236550D</b>
Warranty	<b>12~18 months</b>

Efficiency class	<b>N/A</b>			
Load data	100%	75%	50%	25%
Efficiency	<b>85,6</b>	<b>85,2</b>	<b>85,0</b>	<b>74,0</b> %
Power factor	<b>0,77</b>	<b>0,69</b>	<b>0,64</b>	<b>0,35</b>
Sound pressure level (1m)				<b>56,4</b> dB(A)
Resistance R20 (open)				<b>2,41</b> Ω
Resistance R20	<b>Δ</b>			<b>1,61</b> Ω
Full load torque				<b>53,87</b> Nm
DOL Starting torque vs FL torque				<b>2,05</b>
DOL Pull up torque vs FL torque				<b>1,70</b>
DOL Pull out torque vs FL torque				<b>4,04</b>
Star-Delta Starting torque vs FL torque				<b>0,64</b>
Star-Delta Pull up torque vs FL torque				<b>0,53</b>
Star-Delta Pull out torque vs FL torque				<b>1,26</b>
DOL Starting current vs FL current				<b>7,50</b>
Star Delta Starting current vs FL current				<b>2,34</b>
Rotor Inertia				<b>0,0431</b> kgm <sup>2</sup>
Bearing DE				<b>6308 - ZZ C3</b>
Bearing NDE				<b>6308 - ZZ C3</b>

WI	Change	date	sign.
<b>Dutchi Motors B.V.</b> P.O. Box 5390 NL-6802 EJ ARNHEM Tel : +31-(0)26 - 3541 600 Fax : +31-(0)26 - 3541 650		Discription Drawing made by :	date 19-04-04
		sign. HvD	
		dutchi.motors@dutchi.nl www.dutchi.com	

Power is our commodity, the world is our market !

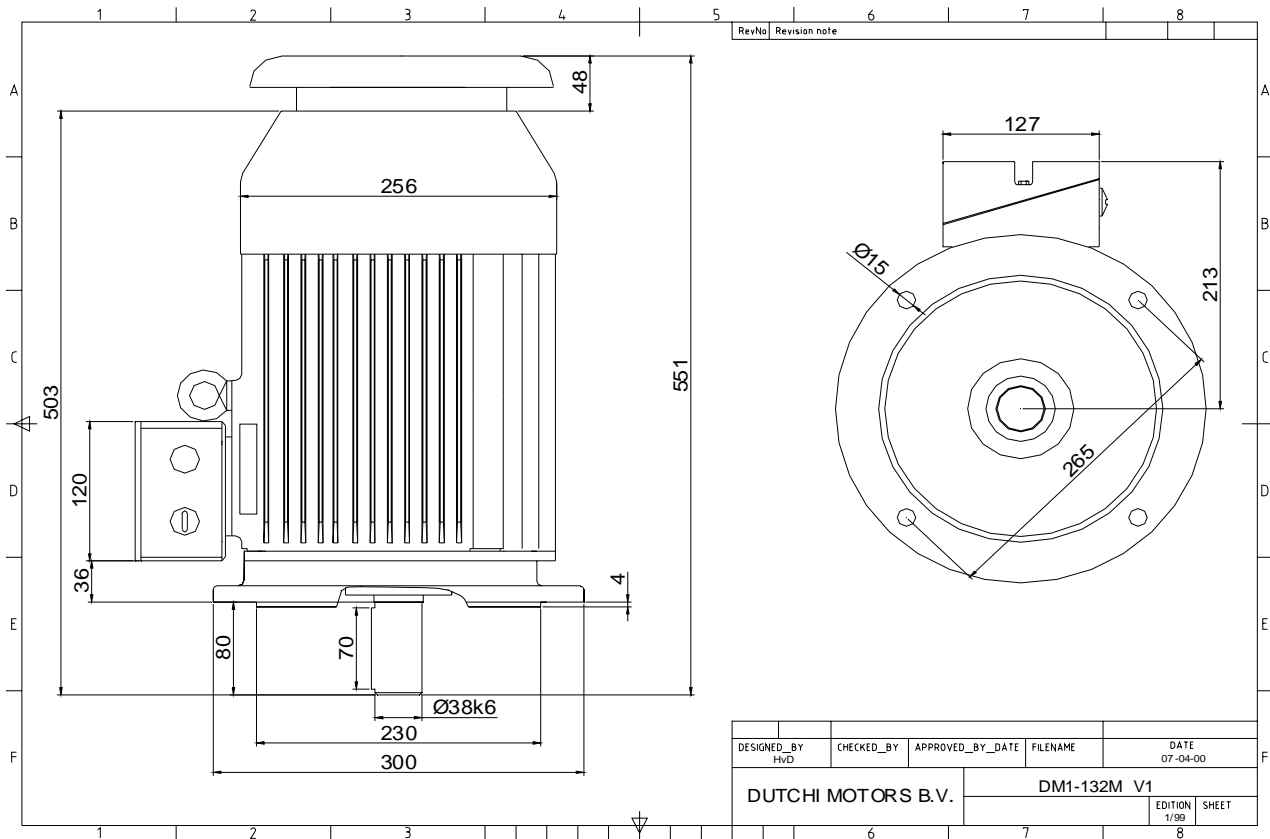

Specification	<b>IEC 60034-1</b>
Manufacturer	<b>Dutchi Motors B.V.</b>
Motor type	<b>DM1- 132 MX6</b>
Rated power	<b>5,5</b> kW <b>S1</b> duty
Speed	<b>975</b> r.p.m
Voltage	<b>400</b> / <b>690</b> V
Frequency	<b>50</b> Hz
Connection	<b>Δ</b> / <b>Y</b>
Amps full load	<b>12,00</b> / <b>6,93</b> A
Amps no-load(400V)	<b>7,30</b> A
Enclosure	<b>IP 55</b>
Insulation Class	<b>F (temp. rise B (80 K))</b>
Max. coolant temp.	<b>40°C</b>
Max. altitude	<b>1.000</b> mtr, above sea level
Comment	<b>3 x PTC 150°C</b>
Cable entries	<b>2 x M32x1,5 + 1 x M20x1,5 (ptc)</b>
Feature	<b>Cast-iron motor</b>
Weight	<b>75,0</b> kg
Catalog no.	<b>11036550D</b>
Warranty	<b>12~18 months</b>

Efficiency class	<b>N/A</b>			
Load data	100%	75%	50%	25%
Efficiency	<b>85,6</b>	<b>85,2</b>	<b>85,0</b>	<b>74,0</b> %
Power factor	<b>0,77</b>	<b>0,69</b>	<b>0,64</b>	<b>0,35</b>
Sound pressure level (1m)				<b>56,4</b> dB(A)
Resistance R20 (open)				<b>2,41</b> Ω
Resistance R20	<b>Δ</b>			<b>1,61</b> Ω
Full load torque				<b>53,87</b> Nm
DOL Starting torque vs FL torque				<b>2,05</b>
DOL Pull up torque vs FL torque				<b>1,70</b>
DOL Pull out torque vs FL torque				<b>4,04</b>
Star-Delta Starting torque vs FL torque				<b>0,64</b>
Star-Delta Pull up torque vs FL torque				<b>0,53</b>
Star-Delta Pull out torque vs FL torque				<b>1,26</b>
DOL Starting current vs FL current				<b>7,50</b>
Star Delta Starting current vs FL current				<b>2,34</b>
Rotor Inertia				<b>0,0431</b> kgm <sup>2</sup>
Bearing DE				<b>6308 - ZZ C3</b>
Bearing NDE				<b>6308 - ZZ C3</b>

WI	Change	date	sign.
<b>Dutchi Motors B.V.</b> P.O. Box 5390 NL-6802 EJ ARNHEM Tel : +31-(0)26 - 3541 600 Fax : +31-(0)26 - 3541 650		Discription Drawing made by :	date sign. HvD
dutchi.motors@dutchi.nl www.dutchi.com		19-04-04	

Power is our commodity, the world is our market !

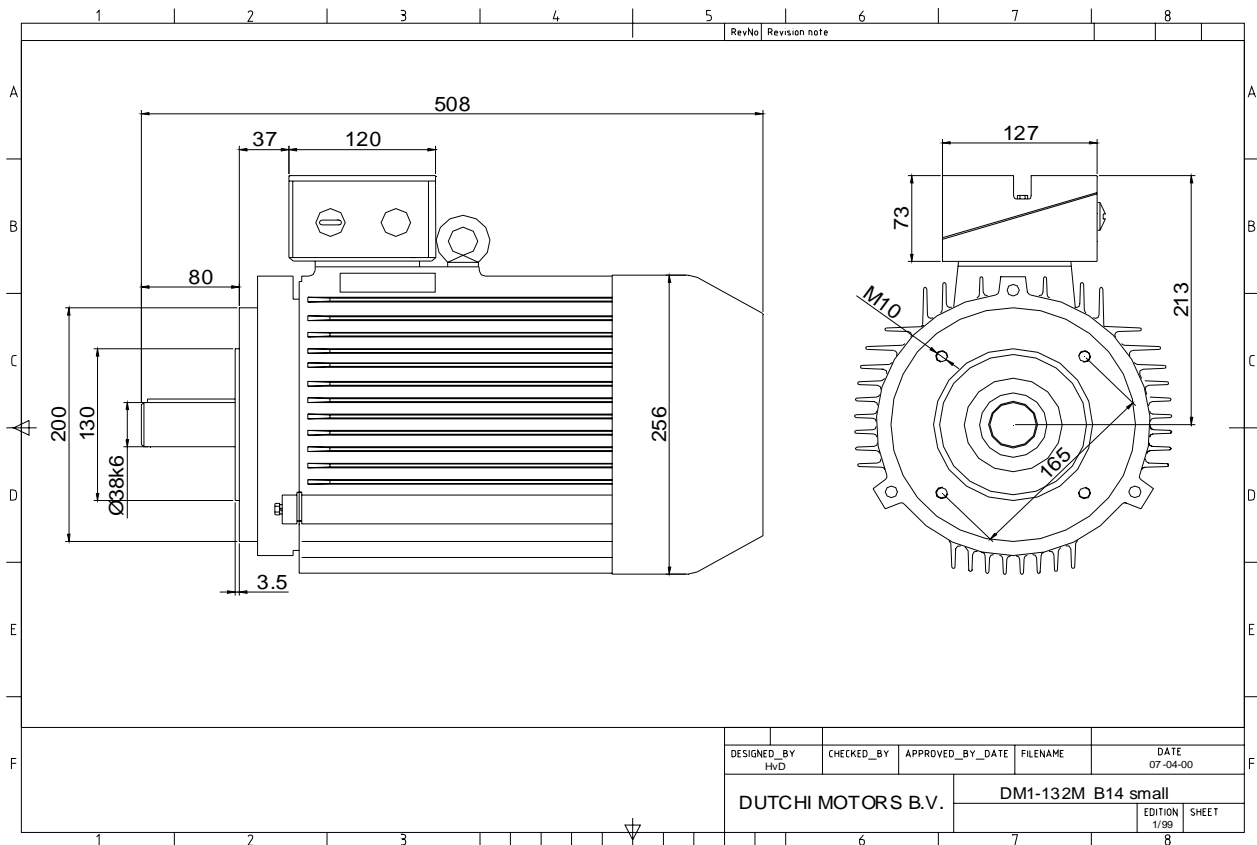

Specification **IEC 60034-1**  
 Manufacturer **Dutchi Motors B.V.**  
 Motor type **DM1- 132 MX6**  
 Rated power **5,5** kW **S1** duty  
 Speed **975** r.p.m  
 Voltage **400 / 690** V  
 Frequency **50** Hz  
 Connection **Δ / Y**  
 Amps full load **12,00 / 6,93** A  
 Amps no-load(400V) **7,30** A  
 Enclosure **IP 55**  
 Insulation Class **F (temp. rise B (80 K))**

Max. coolant temp. **40°C**  
 Max. altitude **1.000** mtr, above sea level  
 Comment **3 x PTC 150°C**  
 Cable entries **2 x M32x1,5 + 1 x M20x1,5 (ptc)**

Feature **Cast-iron motor**  
 Weight **75,0** kg  
 Catalog no. **11336550D**  
 Warranty **12~18 months**

Efficiency class **N/A**  
 Load data 100% 75% 50% 25%  
 Efficiency **85,6 85,2 85,0 74,0** %  
 Power factor **0,77 0,69 0,64 0,35**

Sound pressure level (1m) **56,4** dB(A)  
 Resistance R20 (open) **2,41** Ω  
 Resistance R20 **Δ 1,61** Ω

Full load torque **53,87** Nm  
 DOL Starting torque vs FL torque **2,05**  
 DOL Pull up torque vs FL torque **1,70**  
 DOL Pull out torque vs FL torque **4,04**  
 Star-Delta Starting torque vs FL torque **0,64**  
 Star-Delta Pull up torque vs FL torque **0,53**  
 Star-Delta Pull out torque vs FL torque **1,26**  
 DOL Starting current vs FL current **7,50**  
 Star Delta Starting current vs FL current **2,34**  
 Rotor Inertia **0,0431** kgm<sup>2</sup>

Bearing DE **6308 - ZZ C3**  
 Bearing NDE **6308 - ZZ C3**

WI	Change	date	sign.
<b>Dutchi Motors B.V.</b> P.O. Box 5390 NL-6802 EJ ARNHEM Tel : +31-(0)26 - 3541 600 Fax : +31-(0)26 - 3541 650		Description	date
		Drawing made by :	19-04-04
		<b>dutchi.motors@dutchi.nl</b> <b>www.dutchi.com</b>	

Power is our commodity, the world is our market !

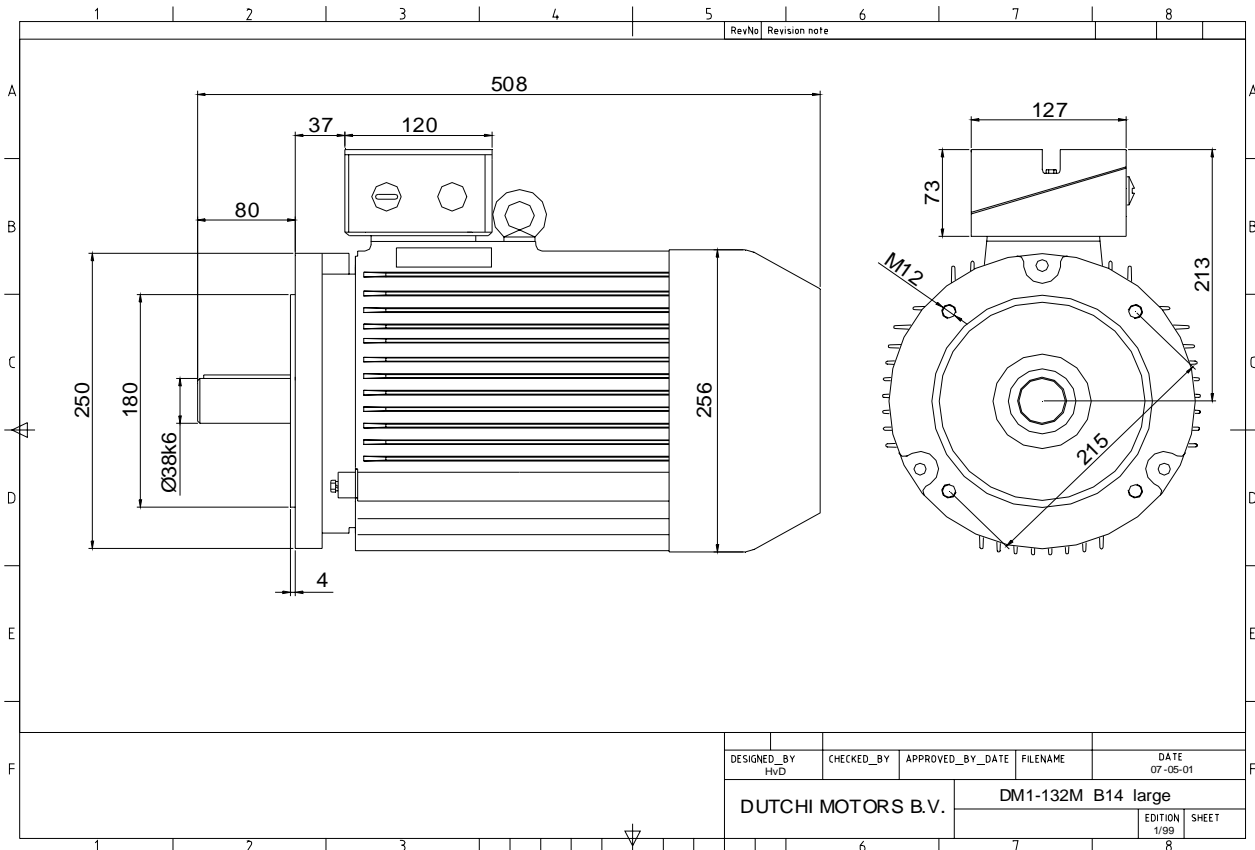

Specification **IEC 60034-1**  
 Manufacturer **Dutchi Motors B.V.**  
 Motor type **DM1- 132 MX6**  
 Rated power **5,5** kW **S1** duty  
 Speed **975** r.p.m  
 Voltage **400 / 690** V  
 Frequency **50** Hz  
 Connection **Δ / Y**  
 Amps full load **12,00 / 6,93** A  
 Amps no-load(400V) **7,30** A  
 Enclosure **IP 55**  
 Insulation Class **F (temp. rise B (80 K))**

Max. coolant temp. **40°C**  
 Max. altitude **1.000** mtr, above sea level  
 Comment **3 x PTC 150°C**  
 Cable entries **2 x M32x1,5 + 1 x M20x1,5 (ptc)**

Feature **Cast-iron motor**  
 Weight **75,0** kg  
 Catalog no. **11436550D**  
 Warranty **12~18 months**

Efficiency class **N/A**  
 Load data 100% 75% 50% 25%  
 Efficiency **85,6 85,2 85,0 74,0** %  
 Power factor **0,77 0,69 0,64 0,35**

Sound pressure level (1m) **56,4** dB(A)  
 Resistance R20 (open) **2,41** Ω  
 Resistance R20 **Δ 1,61** Ω

Full load torque **53,87** Nm  
 DOL Starting torque vs FL torque **2,05**  
 DOL Pull up torque vs FL torque **1,70**  
 DOL Pull out torque vs FL torque **4,04**  
 Star-Delta Starting torque vs FL torque **0,64**  
 Star-Delta Pull up torque vs FL torque **0,53**  
 Star-Delta Pull out torque vs FL torque **1,26**  
 DOL Starting current vs FL current **7,50**  
 Star Delta Starting current vs FL current **2,34**  
 Rotor Inertia **0,0431** kgm<sup>2</sup>

Bearing DE **6308 - ZZ C3**  
 Bearing NDE **6308 - ZZ C3**

WI	Change	date	sign.
Dutchi Motors B.V.		Description	date
P.O. Box 5390		Drawing made by :	19-04-04
NL-6802 EJ ARNHEM			
Tel : +31-(0)26 - 3541 600		dutchi.motors@dutchi.nl	
Fax : +31-(0)26 - 3541 650		www.dutchi.com	